

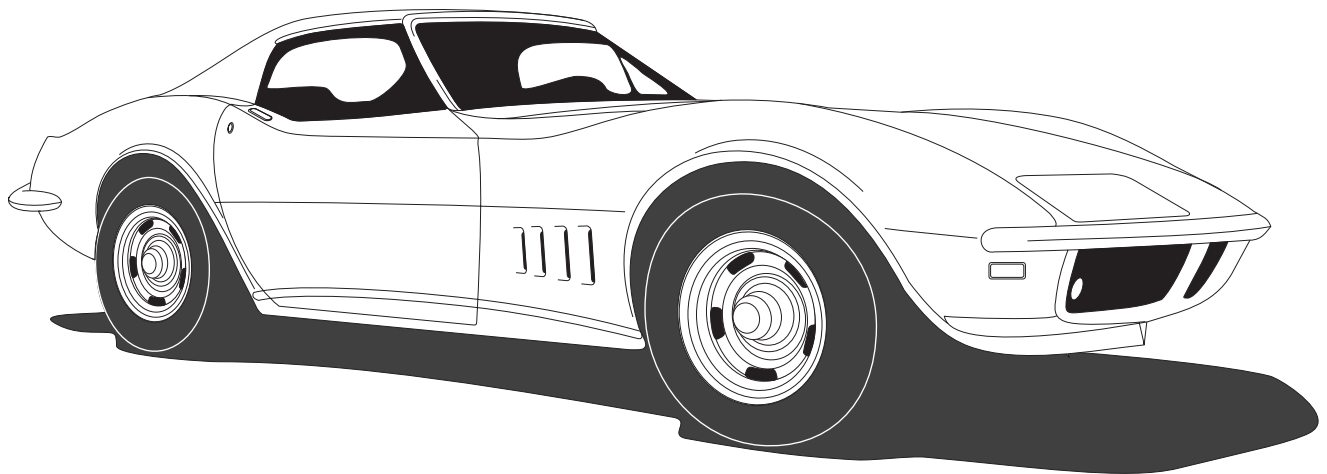

1968-76 CORVETTE

GEN IV w/ FACTORY AIR
564173-PCZ



18865 GOLL ST. - SAN ANTONIO, TX. - 78266 ph.210-654-7171 - fax 210-654-3113



Table of Contents

PAGES

1. COVER
2. TABLE OF CONTENTS
3. PACKING LIST/ PARTS DISCLAIMER
4. INFORMATION PAGE
5. WIRING NOTICE
6. ENGINE COMPARTMENT FIGURES 1.
7. PASSENGER COMPARTMENT, FIGURES 2 & 3.
8. PASSENGER COMPARTMENT CONT. & FRESH AIR COVER FIGURES 4 & 4a.
9. CONDENSER, COMPRESSOR BRACKET & PULLEY'S, FIGURES 5 & 6
10. O.E.M. DEFROST DUCT MODIFICATION, FIGURES 7, 7a & 8
11. DEFROST DUCT INSTALLATION, PASSENGER & DRIVER SIDE A/C DUCT HOSE ADAPTER INSTALLATION, FIGURES 9 & 10.
12. A/C DUCT HOSE ADAPTER FIGURE 10a & CENTER LOUVER DUCT HOSE ADAPTER INSTALLATION, FIGURE 11.
13. EVAPORATOR INSTALLATION, FIGURE 12.
14. EVAPORATOR INSTALLATION CONT., FIGURE 13 & 13a.
15. DRAIN HOSE INSTALLATION FIGURE 14.
16. FIREWALL COVER INSTALLATION FIGURE 15.
17. A/C & HEATER HOSE INSTALLATION FIGURES 16 & 17
18. SMALL BLOCK A/C HOSE ROUTING, FIGURES 18
19. BIG BLOCK A/C HOSE ROUTING, FIGURES 19
20. HEATER CONTROL VALVE INSTALLATION FIGURE 20.
21. CONTROL PANEL WIRING & DUCT HOSE ROUTING, FIGURE 21.
22. EVAPORATOR HARDLINE AND BRACKET INSTALLATION, FIGURE 22.
23. WIRING DIAGRAM
24. OPERATION OF CONTROLS.
25. THERMOSTAT ADJUSTMENT
26. TROUBLE SHOOTING
27. DEFROST DUCT TEMPLATE
28. EVAPORATOR KIT PACKING LIST



GEN IV 1968-76 CORVETTE w/ AC

EVAPORATOR KIT PACKING LIST

EVAPORATOR KIT 564173-PCZ

No.	QTY.	PART No.	DESCRIPTION
1.	1	764173-VCE	1968-76 CORVETTE w/ AC EVAP. SUBCASE
2.	1	784173-PCF	1968-76 CORVETTE w/ AC ACC. KIT

**** BEFORE BEGINNING INSTALLATION OPEN ALL PACKAGES AND CHECK CONTENTS OF SHIPMENT. PLEASE REPORT ANY SHORTAGES DIRECTLY TO VINTAGE AIR WITHIN 15 DAYS. AFTER 15 DAYS, VINTAGE AIR WILL NOT BE RESPONSIBLE FOR MISSING OR DAMAGED ITEMS.**

①

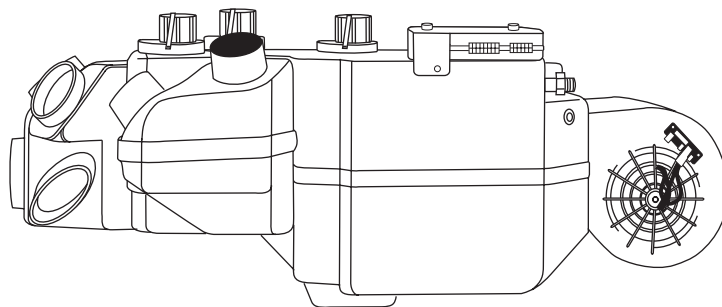

**1968-76 CORVETTE
w/ AC EVAP. SUB CASE
764173-VCE**

②

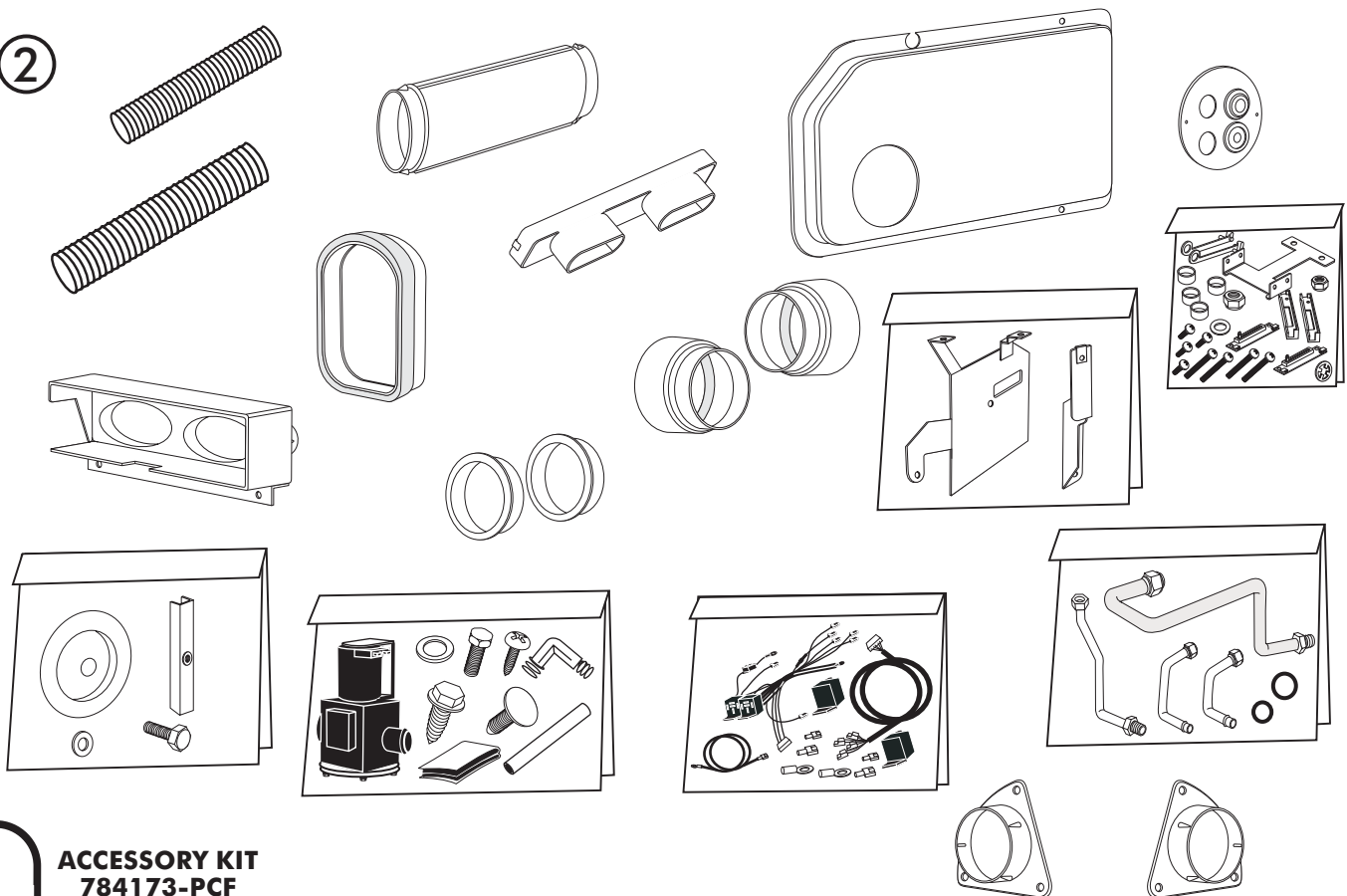

3

**ACCESSORY KIT
784173-PCF**



GEN IV 1968-76 CORVETTE w/ AC

1968-76 CORVETTE GEN IV

IMPORTANT NOTICE-PLEASE READ

FOR MAXIMUM SYSTEM PERFORMANCE VINTAGE AIR RECOMMENDS THE FOLLOWING:

- *18" HEAVY DUTY FAN
- * FAN SHROUD
- *16" SPAL AUXILIARY CONDENSER FAN PACKAGE (PART# 123456-ABC)

THIS KIT DOES NOT CONTAIN HEATER HOSE. YOU MUST PURCHASE 8 FEET OF 5/8" DIA. HEATER HOSE FROM VINTAGE AIR(31800-VUD) OR FROM YOU LOCAL PARTS RETAILER

SAFETY SWITCHES:

YOUR VINTAGE AIR SYSTEM IS EQUIPPED WITH A BINARY PRESSURE SAFETY SWITCH. A BINARY SWITCH (11078-VUS) DISENGAGES THE COMPRESSOR CLUTCH IN CASE OF EXTREME LOW PRESSURE CONDITION (REFRIGERANT LOSS) OR EXCESSIVELY HIGH HEAD PRESSURE (406 lb.), TO PREVENT COMPRESSOR DAMAGE OR HOSE RUPTURE. A TRINARY SWITCH (11076-VUS) COMBINES HI/LO PRESSURE PROTECTION WITH AN ELECTRIC FAN OPERATION SIGNAL AT 254 lbs., AND MAY BE SUBSTITUTED FOR USE WITH ELECTRIC CONDENSER FANS. COMPRESSOR SAFETY SWITCHES ARE EXTREMELY IMPORTANT SINCE AN A/C SYSTEM RELIES ON REFRIGERANT TO CARRY LUBRICATION THROUGH THE SYSTEM.

SERVICE INFO:

EVACUATE THE SYSTEM FOR 35-45 MINUTES WITH SYSTEM COMPONENTS (DRIER, COMPRESSOR, EVAPORATOR AND CONDENSER) AT A TEMPERATURE OF AT LEAST 85° F. ON A COOL DAY THE COMPONENTS CAN BE HEATED WITH A HEAT GUN OR BY RUNNING THE ENGINE WITH THE HEATER ON BEFORE EVACUATING. LEAK CHECK AND CHARGE TO SPECIFICATIONS.

THE PROPER AMOUNT OF REFRIGERANT IS CRITICAL TO PROPER SYSTEM OPERATION. VINTAGE AIR RECOMMENDS OUR SYSTEMS BE CHARGED BY WEIGHT WITH A QUALITY CHARGING STATION OR SCALE.

REFRIGERANT CAPACITIES

134a SYSTEM

CHARGE WITH 1.8 lbs. (11bs. 12ozs) OF REFRIGERANT

R-12 SYSTEM

CHARGE WITH 2.0 lbs. OF REFRIGERANT

LUBRICANT CAPACITIES

NEW COMPRESSOR - NO ADDITIONAL OIL NEEDED
USED COMPRESSOR - CONSULT VINTAGE AIR



IMPORTANT WIRING NOTICE-PLEASE READ

SOME VEHICLES MAY HAVE HAD SOME OR ALL OF THEIR RADIO INTERFERENCE CAPACITORS REMOVED. THERE SHOULD BE A CAPACITOR FOUND AT EACH OF THE FOLLOWING LOCATIONS:

- 1. ON THE POSITIVE TERMINAL OF THE IGNITION COIL**
- 2. IF THERE IS A GENERATOR, ON THE ARMATURE TERMINAL OF THE GENERATOR**
- 3. IF THERE IS A GENERATOR, ON THE BATTERY TERMINAL OF THE VOLTAGE REGULATOR**

MOST ALTERNATORS HAVE A CAPACITOR INSTALLED INTERNALLY TO ELIMINATE WHAT IS CALLED 'WHINING' AS THE ENGINE IS REVVED. IF WHINING IS HEARD IN THE RADIO, OR JUST TO BE EXTRA CAUTIOUS, A RADIO INTERFERENCE CAPACITOR CAN BE ADDED TO THE BATTERY TERMINAL OF THE ALTERNATOR.

IT IS ALSO IMPORTANT THAT THE BATTERY LEAD IS IN GOOD SHAPE AND THAT THE GROUND LEADS ARE NOT COMPROMISED. THERE SHOULD BE A HEAVY GROUND FROM THE BATTERY TO THE ENGINE BLOCK, AND ADDITIONAL GROUNDS TO THE BODY AND TO THE CHASSIS.

IF THESE PRECAUTIONS ARE NOT OBSERVED, IT IS POSSIBLE FOR VOLTAGE SPIKES TO BE PRESENT ON THE BATTERY LEADS. THESE SPIKES COME FROM IGNITION SYSTEMS, CHARGING SYSTEMS, AND FROM TURNING SOME OF THE VEHICLE'S OTHER SYSTEMS ON AND OFF. MODERN COMPUTER OPERATED EQUIPMENT CAN BE SENSITIVE TO VOLTAGE SPIKES ON THEIR POWER LEADS, WHICH CAN CAUSE UNEXPECTED RESETS, STRANGE BEHAVIOR, AND MAY ALSO CAUSE PERMANENT DAMAGE.

VINTAGE AIR STRIVES TO HARDEN THEIR PRODUCTS AGAINST THESE TYPES OF ELECTRICAL NOISE, BUT THERE IS A POINT WHERE A VEHICLE'S ELECTRICAL SYSTEM CAN BE DEGRADED SO MUCH THAT NOTHING CAN HELP.

RADIO INTERFERENCE CAPACITORS SHOULD BE AVAILABLE AT MOST AUTO & TRUCK PARTS SUPPLIERS. THEY TYPICALLY ARE CYLINDRICAL IN SHAPE, A LITTLE OVER AN INCH LONG, A LITTLE OVER A HALF INCH IN DIAMETER, THEY HAVE A SINGLE LEAD COMING FROM ONE END OF THE CYLINDER WITH A TERMINAL ON THE END OF THE WIRE, AND THEY WILL HAVE A MOUNTING CLIP WHICH IS SCREWED INTO A GOOD GROUND ON THE VEHICLE. THE SPECIFIC VALUE OF THE CAPACITANCE IS NOT TOO SIGNIFICANT, IN COMPARISON TO IGNITION CAPACITORS THAT ARE MATCHED WITH THE COIL TO REDUCE PITTING OF THE POINTS.

- CARE MUST BE TAKEN WHEN INSTALLING THE COMPRESSOR LEAD, NOT TO SHORT IT TO GROUND. THE COMPRESSOR LEAD MUST NOT BE CONNECTED TO A CONDENSER FAN OR ANY OTHER AUXILIARY DEVICE. SHORTING TO GROUND OR CONNECTING TO A CONDENSER FAN OR ANY OTHER AUXILIARY DEVICE WILL CAUSE SEVERE DAMAGE TO THE ECU.
- WHEN INSTALLING GROUND LEADS ON GEN IV SYSTEMS, THE BLOWER CONTROL GROUND AND ECU GROUND MUST BE CONNECTED DIRECTLY TO THE NEGATIVE BATTERY POST.
- THE HEATER CONTROL VALVE IS A NORMALLY OPEN VALVE. IT MUST BE CONNECTED TO THE ECU TO BLOCK WATER FLOW IN AC MODE.



INSTALLATION INSTRUCTIONS FOR 1968-1976 CORVETTE

BEFORE STARTING THE AIR CONDITIONER INSTALLATION, CHECK FOR PROPER OPERATION OF ALL COMPONENTS (RADIO, LIGHTS, WIPERS, ETC.). STUDY THE INSTRUCTIONS, ILLUSTRATIONS AND DIAGRAMS. FOR EASE OF INSTALLATION CHECK OFF (✓) EACH PROCEDURE PRIOR TO MOVING ON TO THE NEXT STEP.

ENGINE COMPARTMENT

- DISCONNECT BATTERY
- REMOVE HOOD TO EASE INSTALLATION
- DRAIN RADIATOR
- EVACUATE THE A/C SYSTEM IF NECESSARY
- REMOVE O.E.M. CONDENSER AND DRIER
- REMOVE O.E.M. A/C LINES FROM COMPRESSOR TO EVAPORATOR
- REMOVE O.E.M. COMPRESSOR AND COMPRESSOR BRACKET
- REMOVE O.E.M. BLOWER ASSEMBLY AND COVER
- REMOVE O.E.M. EVAPORATOR AND COVER
- REMOVE O.E.M. A/C HARNESS AND VACUUM HARNESS. (DISCARD)
- INSTALL 1 1/2" PLUGS IN FIREWALL AS SHOWN IN FIGURE 1a.

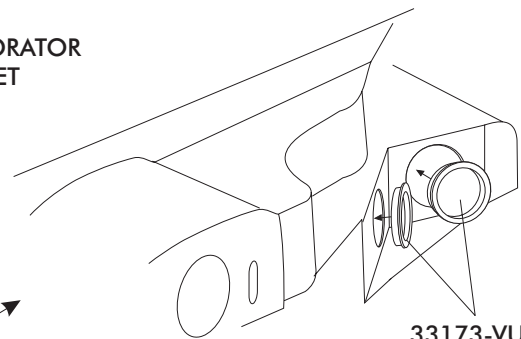

FIGURE 1a

33173-VUI
1 1/2" PLUG

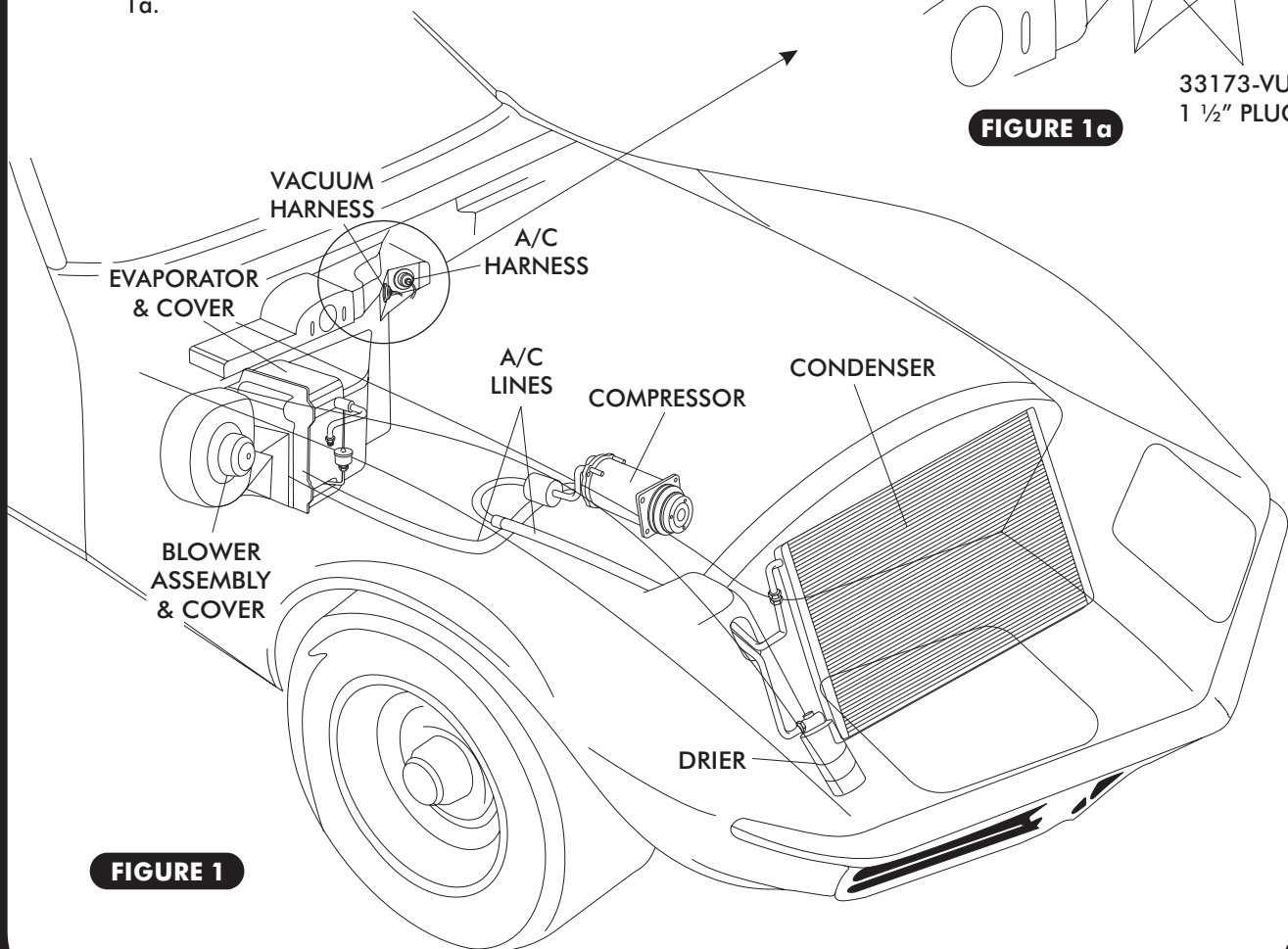

FIGURE 1



GEN IV 1968-76 CORVETTE w/ AC

PASSENGER COMPARTMENT

- REMOVE PASSENGER SIDE DASH
- DISCONNECT CENTER DASH AND PULL FORWARD TO REMOVE OEM A/C DUCT
- REMOVE OEM RADIO
- REMOVE CONTROL PANEL (RETAIN), REFER TO CONTROL PANEL CONVERSION KIT TO ASSEMBLE CONTROL PANEL.
- DROP STEERING COLUMN
- DISCONNECT DRIVER SIDE DASH AND PULL FORWARD

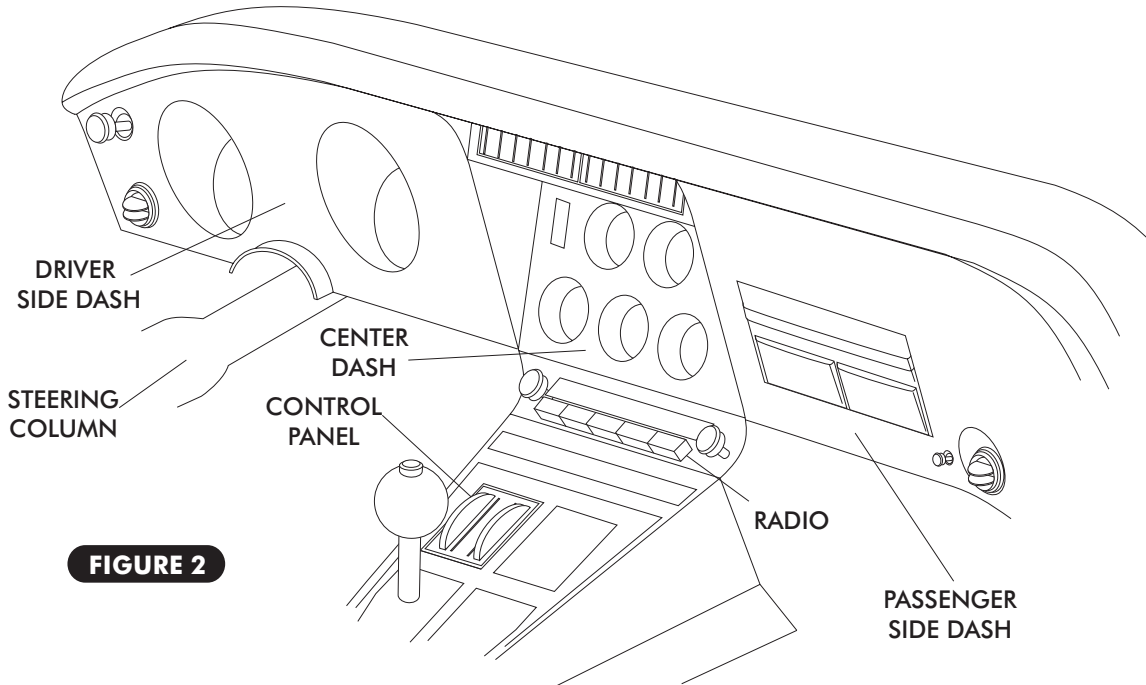

FIGURE 2

- REMOVE THE PASSENGER SIDE, CENTER, AND DRIVER SIDE A/C DUCTS AS SHOWN IN FIGURE 3 BELOW.
- REMOVE THE FLOOR HEATER DUCT AS SHOWN.

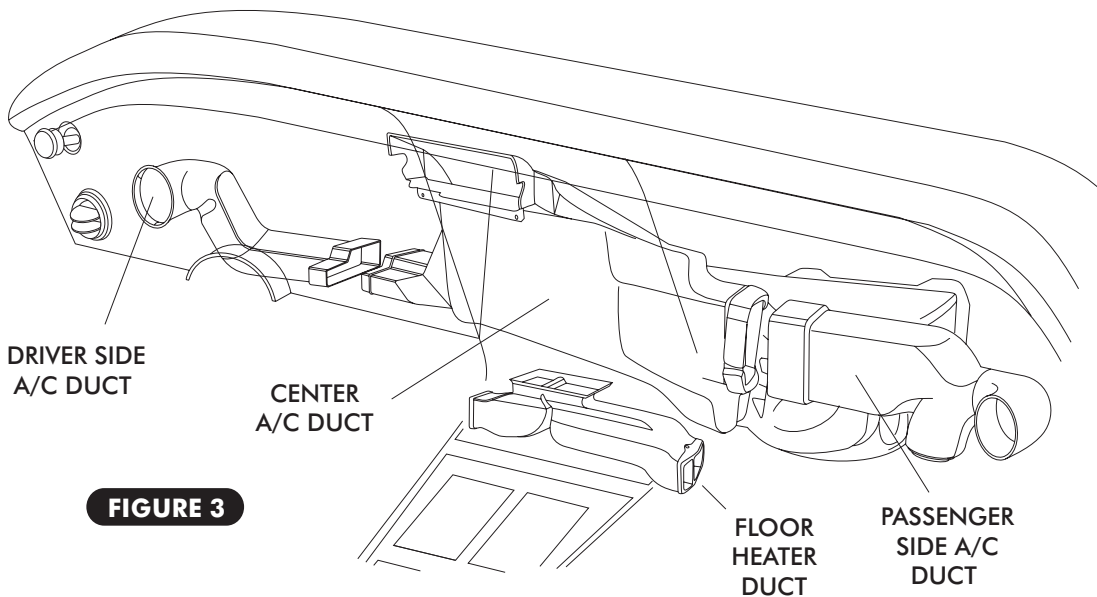

FIGURE 3



GEN IV 1968-76 CORVETTE w/ AC

- ❑ REMOVE THE DEFROST DUCT. (RETAIN)
- ❑ REMOVE THE HEATER HOUSING FROM UNDER THE DASH.
- ❑ REMOVE THE KICK PANEL VACUUM CONTROL ASM AND DISCARD. SEE FIGURE 4a BELOW.
- ❑ USING (2) 8 x 1/2 PH PAN HEAD SCREWS INSTALL THE KICK PANEL FRESH AIR CAP AS SHOWN IN FIGURE 4a BELOW.

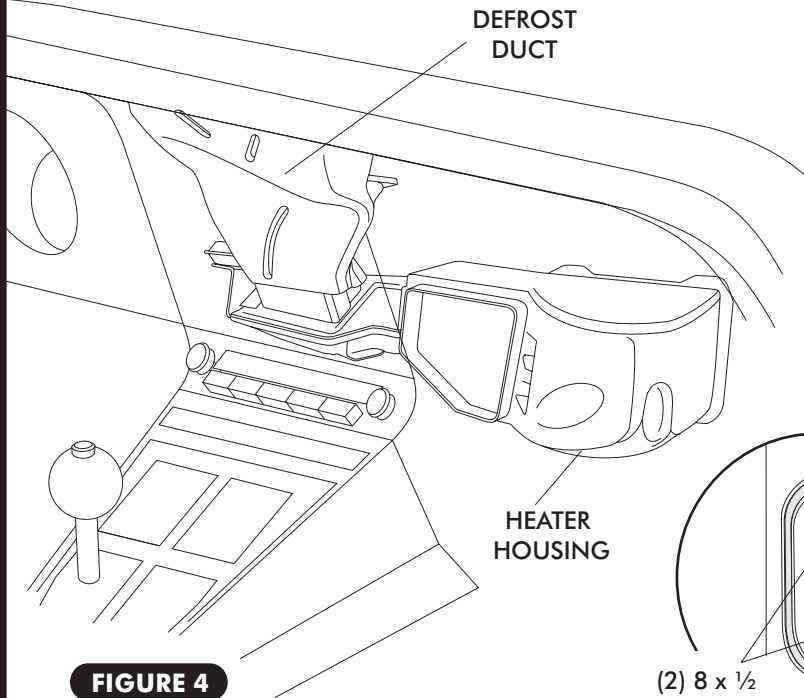

FIGURE 4

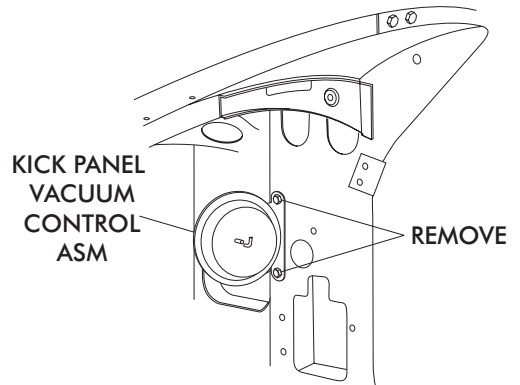
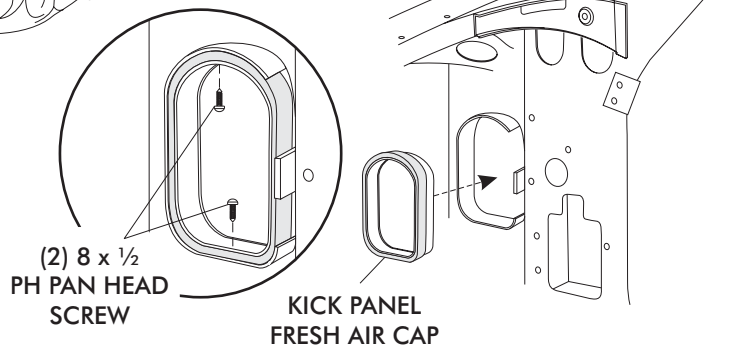

FIGURE 4a



FRESH AIR COVER INSTALLATION

- ❑ APPLY A 1/4" BEAD OF SILICONE AROUND THE BACK SIDE OF THE FRESH AIR CAP AS SHOWN IN FIGURE 4b BELOW.
- ❑ ATTACH FRESH AIR CAP TO FIREWALL USING A 1/4-20 x 1" BOLT AND WASHER, SEE FIGURE 4b.



FIGURE 4b

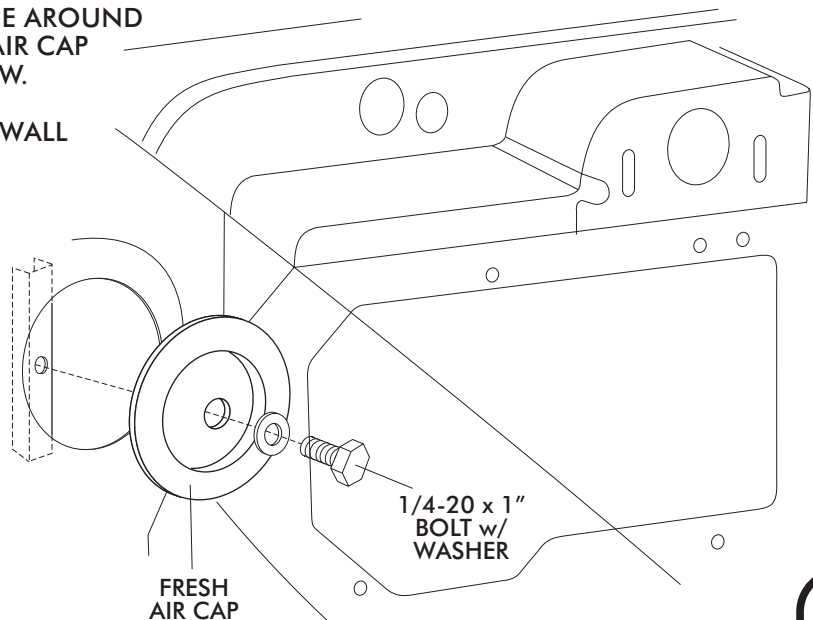



GEN IV 1968-76 CORVETTE w/ AC

CONDENSER ASSEMBLY & INSTALLATION

- REFER TO SEPARATE INSTRUCTIONS INCLUDED WITH THE CONDENSER KIT TO INSTALL THE CONDENSER. REFER TO FIGURE 5 BELOW FOR CONDENSER LOCATION.

FIGURE 5

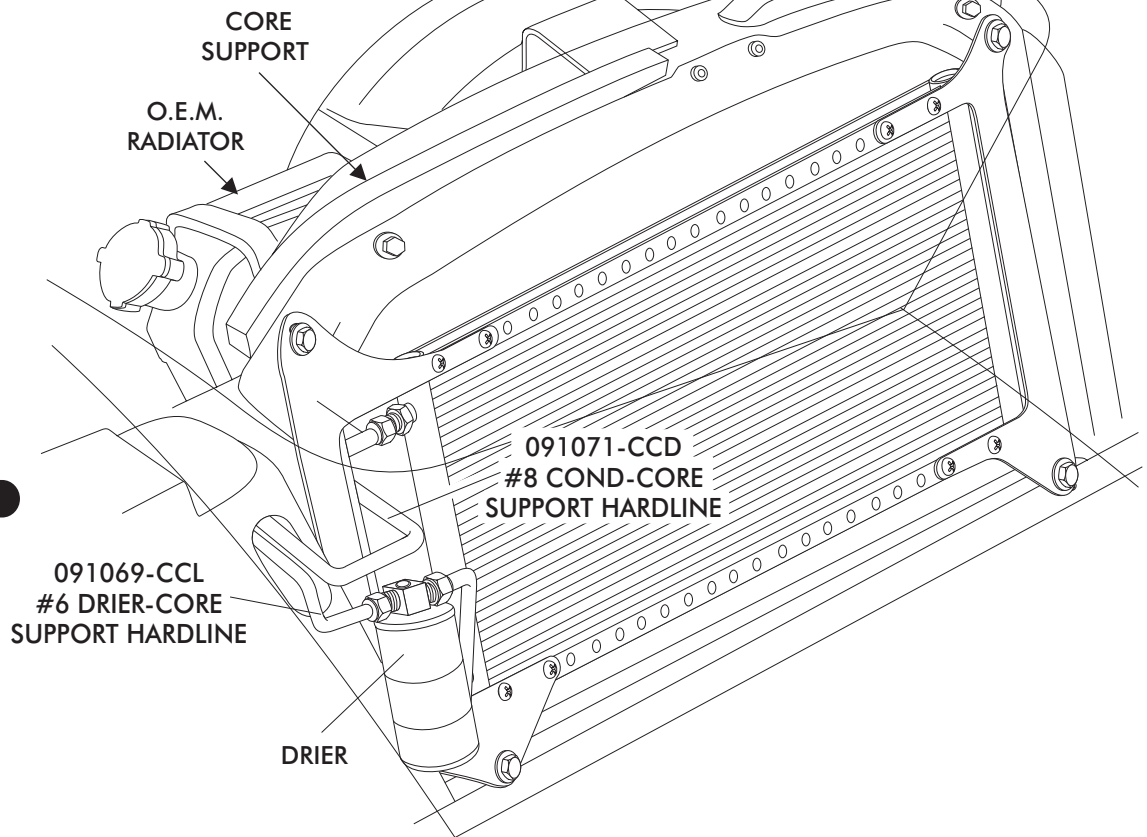

COMPRESSOR & BRACKETS

- REFER TO SEPARATE INSTRUCTIONS INCLUDED WITH THE BRACKET KIT TO INSTALL THE COMPRESSOR BRACKET. REFER TO FIGURE 6 BELOW FOR COMPRESSOR MOUNTING POSITION.

PULLEYS

- IN MOST INSTANCES EXISTING BELT LENGTHS WILL REMAIN THE SAME. SEE FIGURE 6 BELOW.

PULLEYS (VINTAGE AIR) SHORT PUMP SMALL BLOCK CHEVY (STEEL PULLEY)

- 22503-VCA - WATER PUMP PULLEY (DOUBLE GROOVE)
- 22506-VCA - CRANKSHAFT PULLEY (DOUBLE GROOVE) (WITH POWER STEERING A 3 GROOVE CRANK PULLEY IS REQUIRED)
- 22507-VCA - CRANKSHAFT PULLEY (TRIPLE GROOVE)

NOTE: BELT ROUTING MAY VARY WITH DIFFERENT BRACKET SETS. ALWAYS REFER TO INSTRUCTIONS INCLUDED WITH BRACKETS.

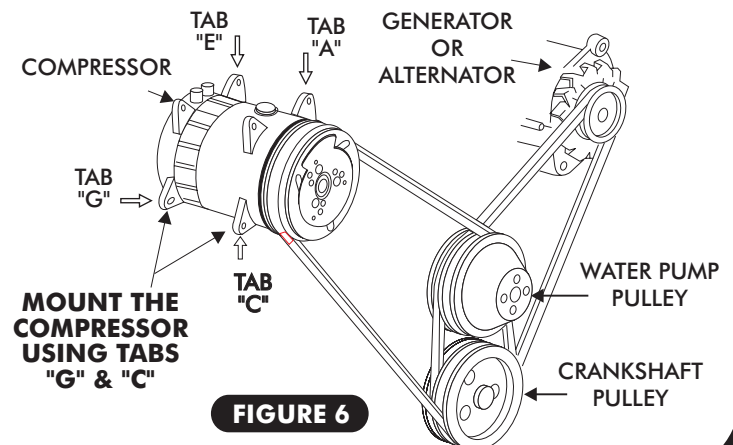

FIGURE 6

O.E.M. DEFROST DUCT MODIFICATION

- ☐ MEASURE 6" FROM THE TOP OF THE DEFROST DUCT AND MARK AS SHOWN IN FIGURE 7 BELOW. CUT OFF THE BOTTOM PORTION OF THE DEFROST DUCT AS SHOWN.

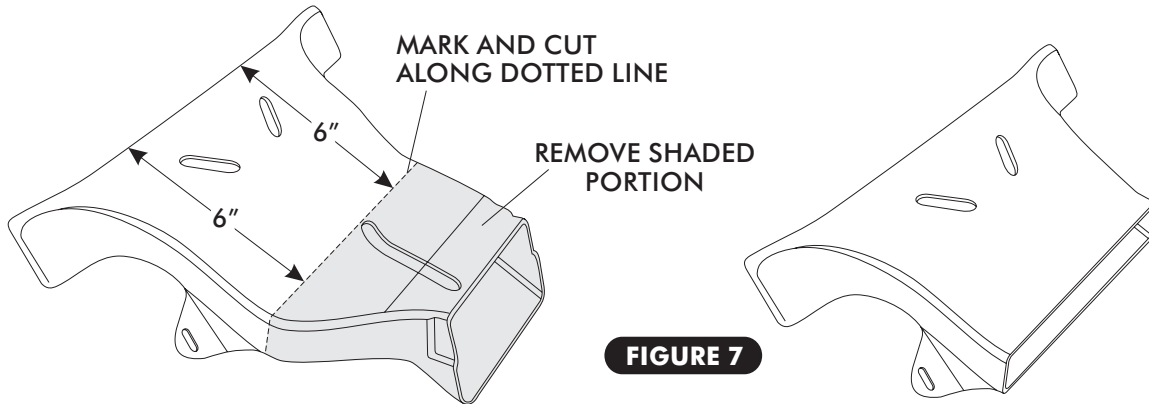

FIGURE 7

- ☐ LOCATE THE DEFROST DUCT TEMPLATE ON PAGE 27, PLACE THE TEMPLATE OVER THE DEFROST DUCT AS SHOWN IN FIGURE 7a BELOW.
- ☐ USING A PENCIL OR SCRIBE MARK ALONG THE EDGE OF THE TEMPLATE AS SHOWN.
- ☐ REMOVE THE TEMPLATE AND CUT ALONG THE DOTTED LINE AND REMOVE THE TOP PORTION OF THE DEFROST DUCT AS SHOWN IN FIGURE 7a. **NOTE: DO NOT CUT COMPLETELY THROUGH THE DEFROST DUCT, ONLY REMOVE THE SHADE PORTION AS SHOWN.**

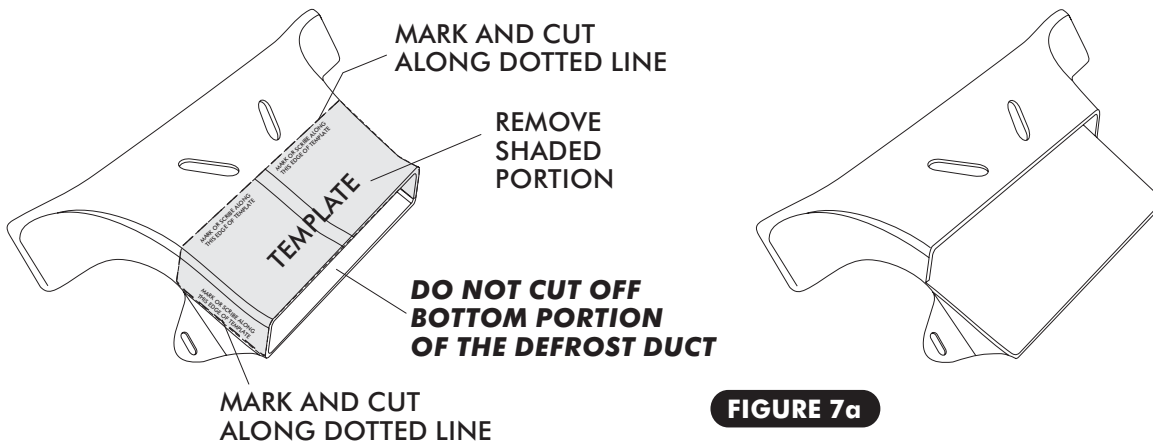

FIGURE 7a

- ☐ INSTALL THE DEFROST DUCT HOSE ADAPTER AS SHOWN IN FIGURE 8 BELOW.

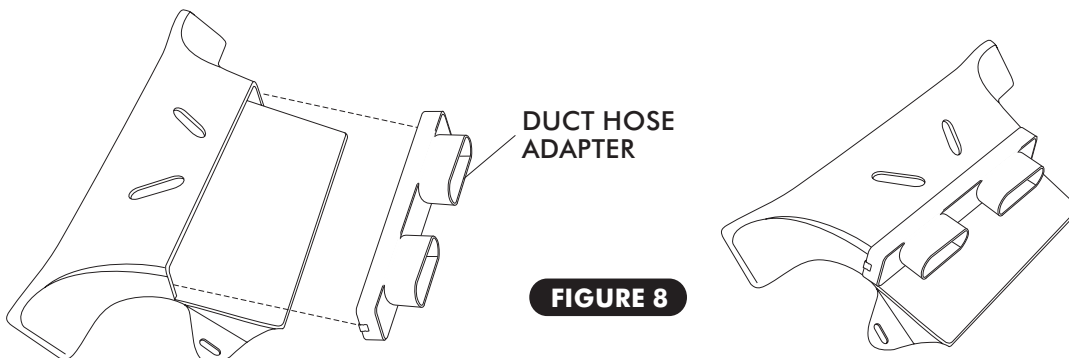

FIGURE 8



GEN IV 1968-76 CORVETTE w/ AC

DEFROST DUCT & PS AND DS SIDE A/C DUCT HOSE ADAPTER INSTALLATION

- USING THE O.E.M. DEFROST DUCT MOUNTING SCREWS INSTALL THE DEFROST DUCT WITH HOSE ADAPTER AS SHOWN IN FIGURE 9 BELOW.
- REMOVE VENT KNOBS AND RETAIN

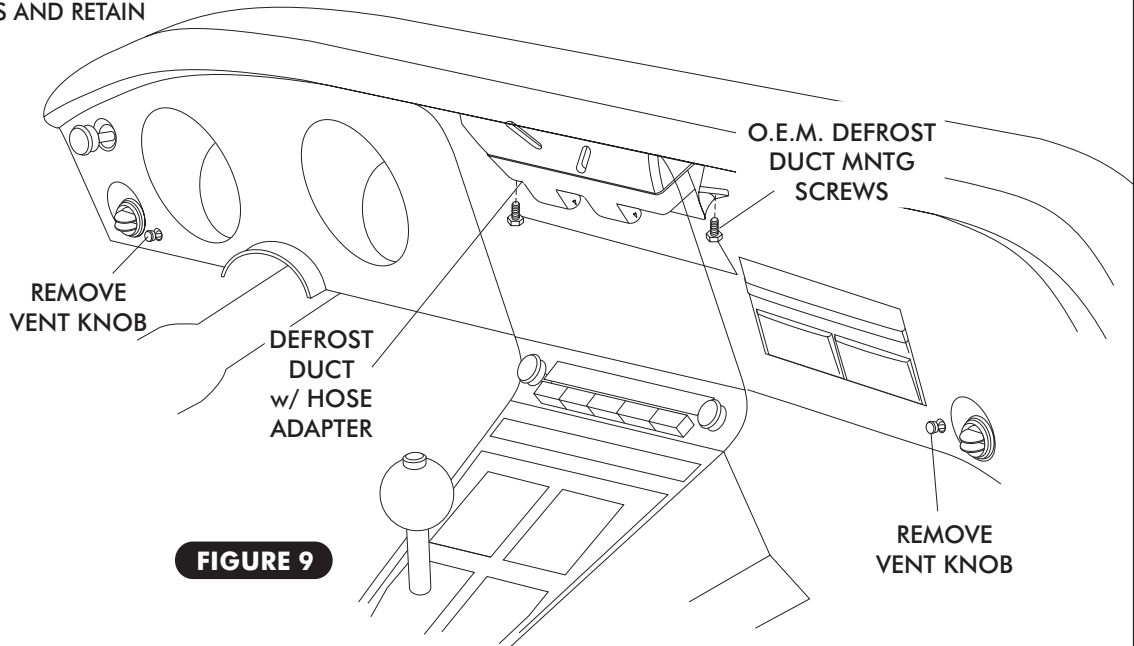

FIGURE 9

- REMOVE THE PASSENGER AND DRIVER SIDE VENT ADAPTERS (DISCARD) AS SHOWN IN FIGURE 10 BELOW. **NOTE: RETAIN MOUNTING HARDWARE.**
- INSTALL THE INNER AND OUTER A/C DUCT HOSE ADAPTERS AS SHOWN IN FIGURE 10 BELOW. USE O.E.M. SCREWS TO SECURE ADAPTERS TO DASH.
- INSTALL THE VENT KNOB AS SHOWN USING A 10-24 x 1 1/4" PH PAN HEAD SCREW AND 3/16" FLAT WASHER. **NOTE: THE PASSENGER SIDE INSTALLATION IS SHOWN BELOW IN FIGURE 10, REPEAT THE SAME STEPS FOR THE DRIVER SIDE INSTALLATION.**
- SEE FIGURE 10a PAGE 12 FOR A COMPLETELY ASSEMBLED VIEW OF A/C DUCT HOSE ADAPTER.

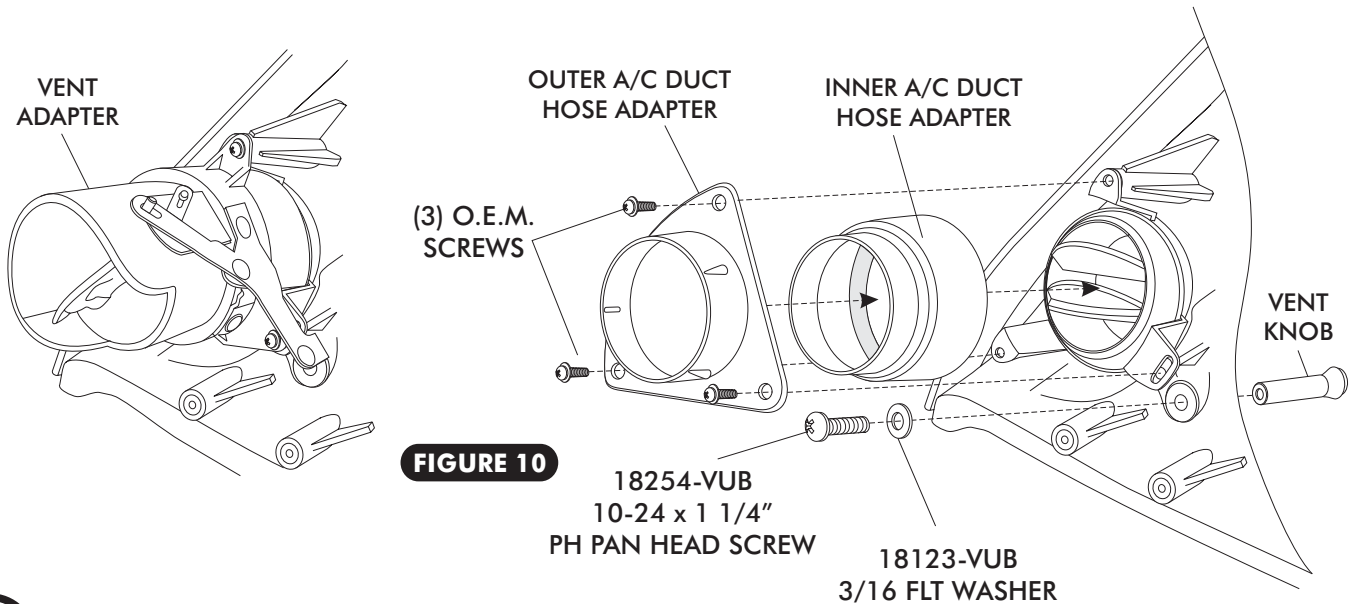

FIGURE 10

18254-VUB
10-24 x 1 1/4"
PH PAN HEAD SCREW

18123-VUB
3/16 FLT WASHER



GEN IV 1968-76 CORVETTE w/ AC

PS & DS SIDE AC DUCT HOSE ADAPTER INSTALLATION

- ☐ COMPLETELY ASSEMBLED VIEW OF AC DUCT HOSE ADAPTER.

FIGURE 10a

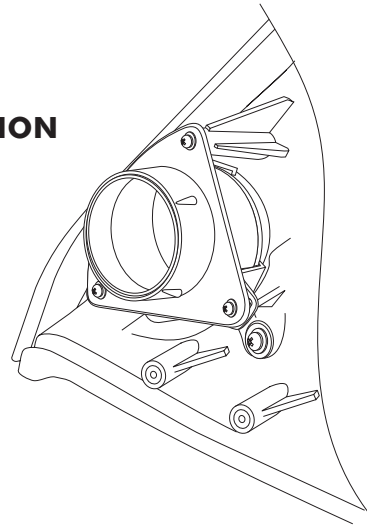

CENTER LOUVER ADAPTER INSTALLATION

- ☐ INSTALL CENTER LOUVER HOSE ADAPTER USING O.E.M. SCREWS AS SHOWN IN FIGURE 11 BELOW.

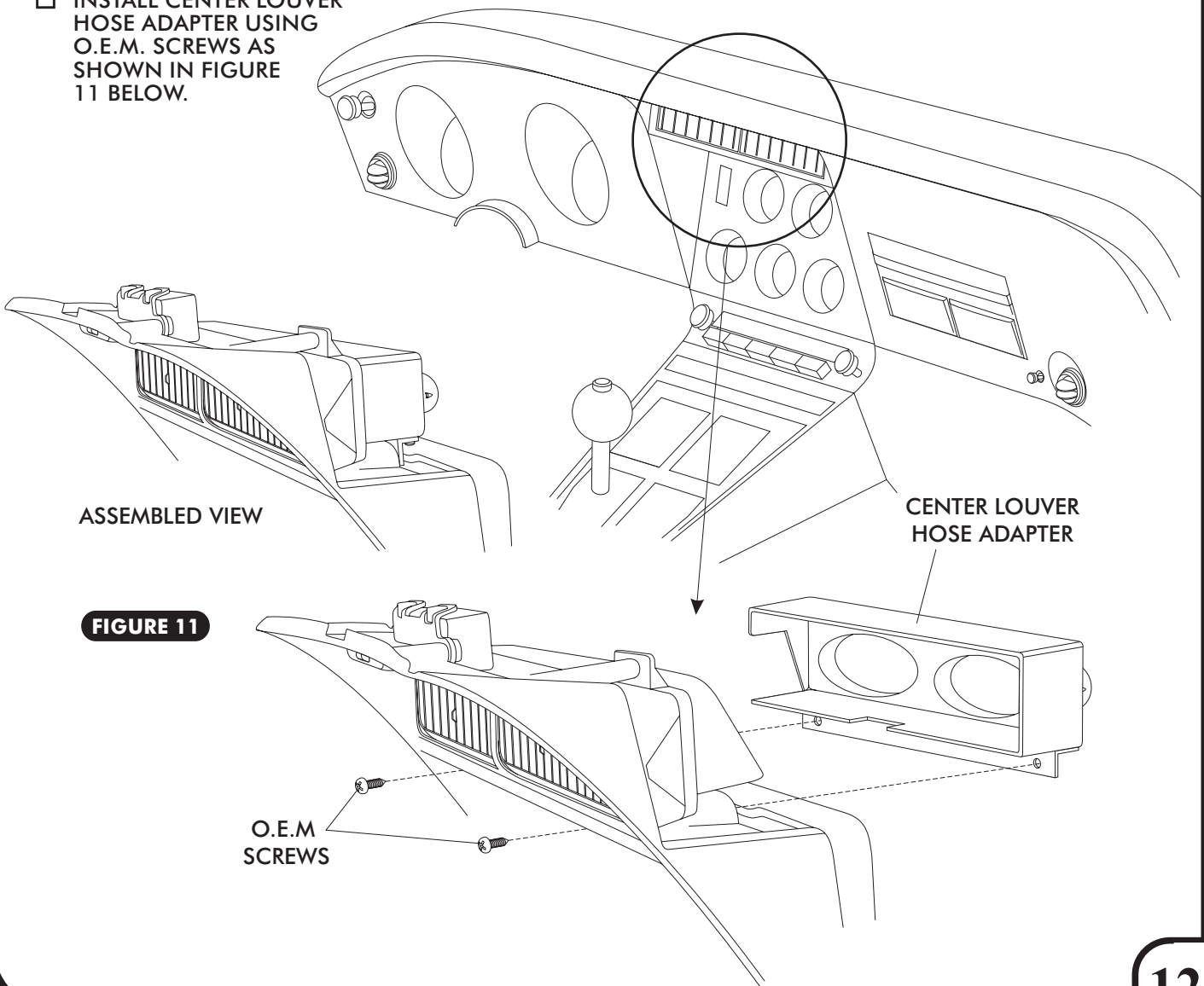

FIGURE 11



GEN IV 1968-76 CORVETTE w/ AC

EVAPORATOR INSTALLATION

- ON A WORK BENCH, INSTALL EVAPORATOR REAR BRACKET, AND INSTALL EVAPORATOR HARDLINES WITH PROPERLY LUBRICATED O-RINGS. (SEE FIGURE 16, PAGE 17, AND FIGURES 22, PAGE 22.)
- INSTALL FRONT MOUNTING BRACKET ON EVAPORATOR USING (2) 1/4-20 x 1/2" HEX BOLTS AND TIGHTEN AS SHOWN IN FIGURE 12, BELOW.
- INSTALL 4-VENT A/C PLENUM TO EVAPORATOR USING (2) 10/32 x 1/2" SCREWS. SEE FIGURE 13a, PAGE 14.
- LIFT EVAPORATOR UNIT UP UNDER THE DASHBOARD SEE FIGURE 13, PAGE 14. SECURE LOOSELY TO THE FIREWALL FROM THE ENGINE COMPARTMENT SIDE USING A 1/4-20 x 1" BOLT AND WASHER, SEE FIGURE 13, PAGE 14.
- USING A #14 x 3/4" SHEETMETAL SCREW SECURE THE FRONT EVAPORATOR MOUNTING BRACKET TO THE INNER COWL BY ALIGNING THE LEFT HOLE IN FRONT EVAPORATOR MOUNTING BRACKET WITH THE O.E.M. HOLE IN INNER COWL. SEE FIGURE 13, PAGE 14
- TO SECURE THE RIGHT SIDE OF THE FRONT MOUNTING BRACKET, WITH EVAPORATOR MOUNTING BRACKET IN PLACE DRILL A 3/16" HOLE IN INNER COWL USING THE RIGHT MOUNTING BRACKET HOLE AS A GUIDE. SECURE THE BRACKET TO THE INNER COWL USING A #14 x 3/4" SHEETMETAL SCREW SEE FIGURE 13, PAGE 14
- VERIFY THAT EVAPORATOR UNIT IS LEVEL AND SQUARE TO THE DASH, THEN TIGHTEN ALL MOUNTING BOLTS. (**NOTE:** TIGHTEN THE BOLT ON FIREWALL FIRST, THEN THE FRONT MOUNTING BRACKET SCREWS.)

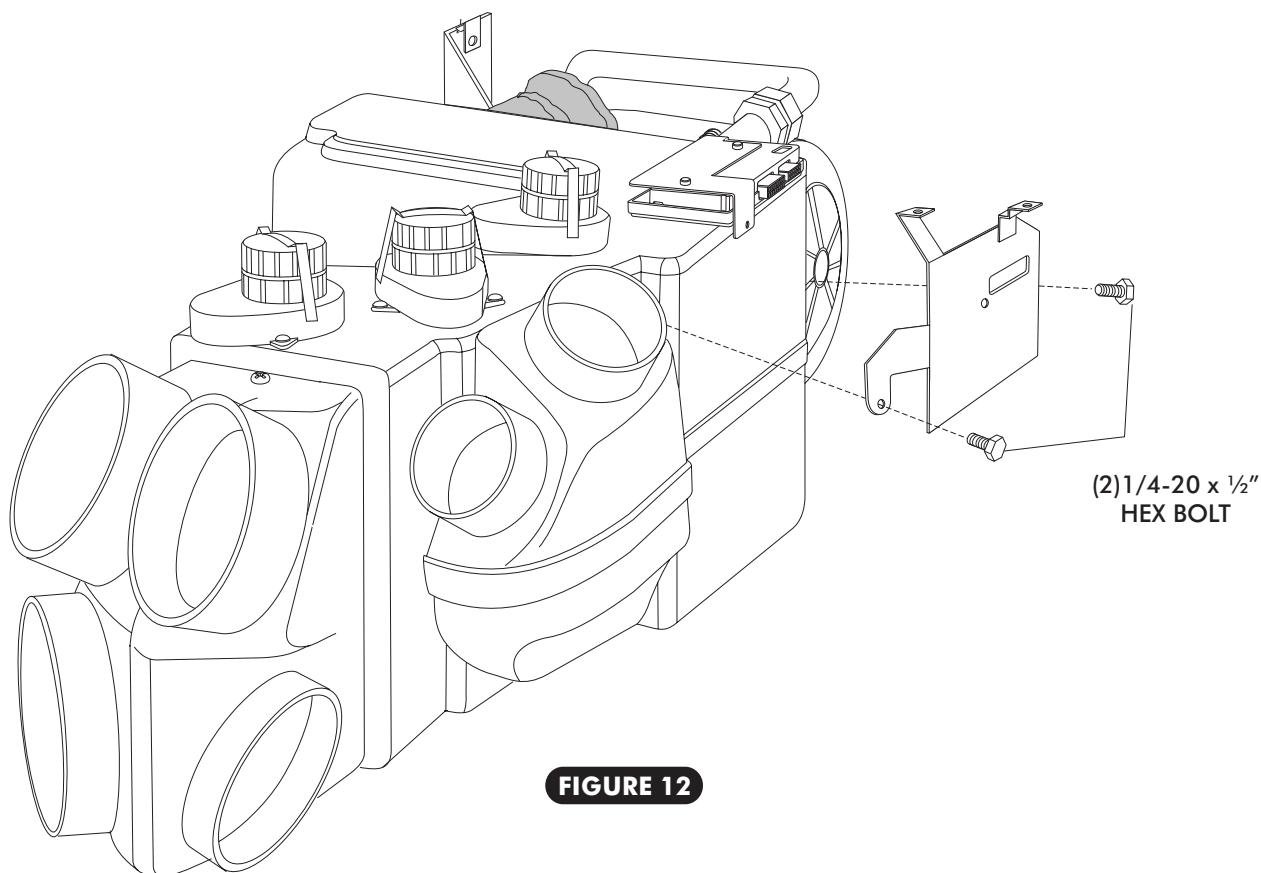

FIGURE 12



GEN IV 1968-76 CORVETTE w/ AC

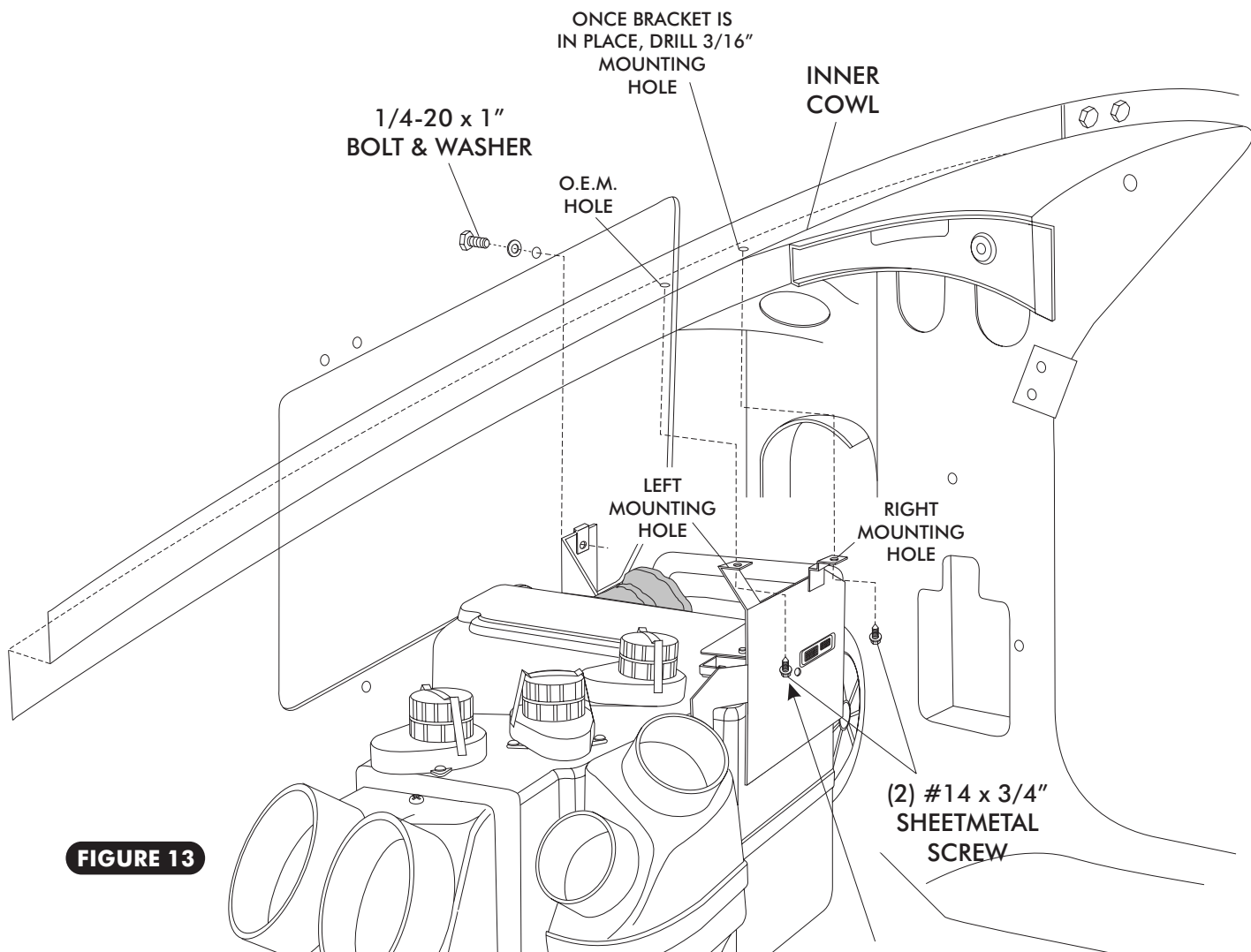
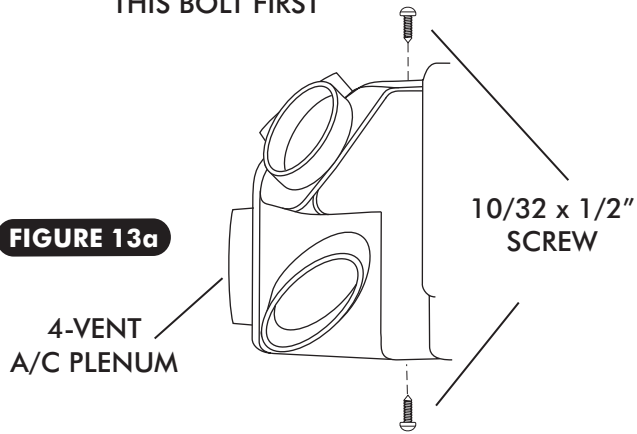

FIGURE 13

*** NOTE: INSTALL THIS BOLT FIRST**

FIGURE 13a





DRAIN HOSE INSTALLATION

- IN-LINE WITH THE DRAIN, LIGHTLY MAKE A MARK ON THE FIREWALL. MEASURE ONE INCH DOWN AND DRILL A 5/8" HOLE THROUGH THE FIREWALL. SEE FIGURE 14 BELOW.
- INSTALL DRAIN HOSE TO BOTTOM OF EVAPORATOR UNIT AND ROUTE THROUGH FIREWALL. SEE FIGURE FIGURE 14, BELOW.

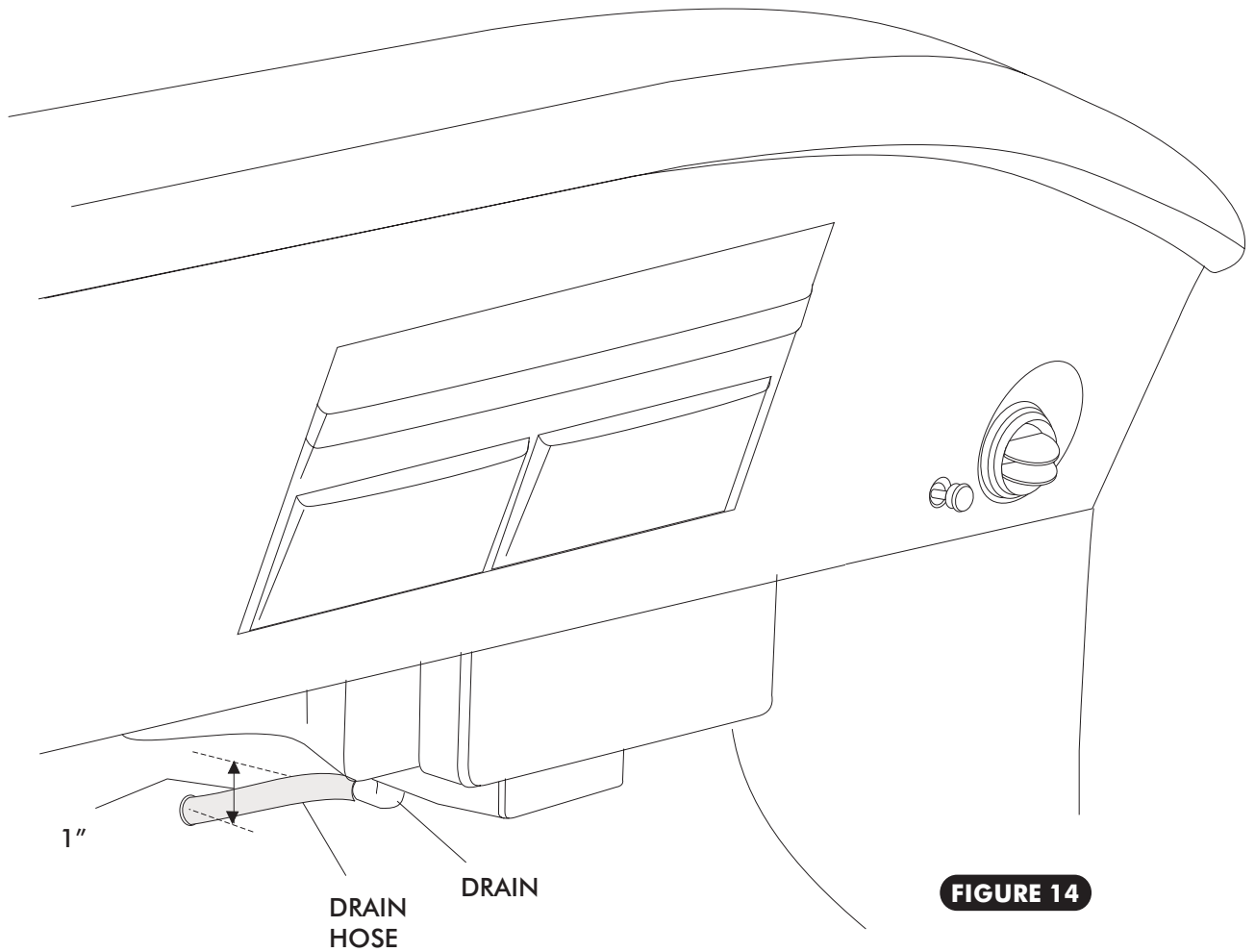



GEN IV 1968-76 CORVETTE w/ AC

FIREWALL COVER

- ❑ APPLY A 1/4" BEAD OF SILICONE AROUND THE BACK SIDE OF THE FIREWALL COVER AS SHOWN IN FIGURE 15 BELOW.
- ❑ PASS LINES THROUGH FIREWALL COVER, AND SECURE WITH (2) 7/16 PANEL RETAINERS. SEE FIGURE 15 BELOW.
- ❑ ONCE THE FIREWALL COVER IS IN PLACE LOCATE THE HOLE ON THE LEFT SIDE OF THE FIREWALL COVER AND DRILL A 3/8" HOLE THROUGH THE FIREWALL AND INSTALL A 7/16 PANEL RETAINER TO SECURE THE LEFT SIDE OF THE FIREWALL COVER TO FIREWALL. SEE FIGURE 15 BELOW.
- ❑ APPLY A 1/4" BEAD OF SILICONE AROUND THE BACK SIDE OF THE FIREWALL COVER CAP AS SHOWN IN FIGURE 15 BELOW. USING (2) #8 x 1/2" PH PAN HEAD SCREWS INSTALL FIREWALL COVER CAP AS SHOWN IN FIGURE 15 BELOW.

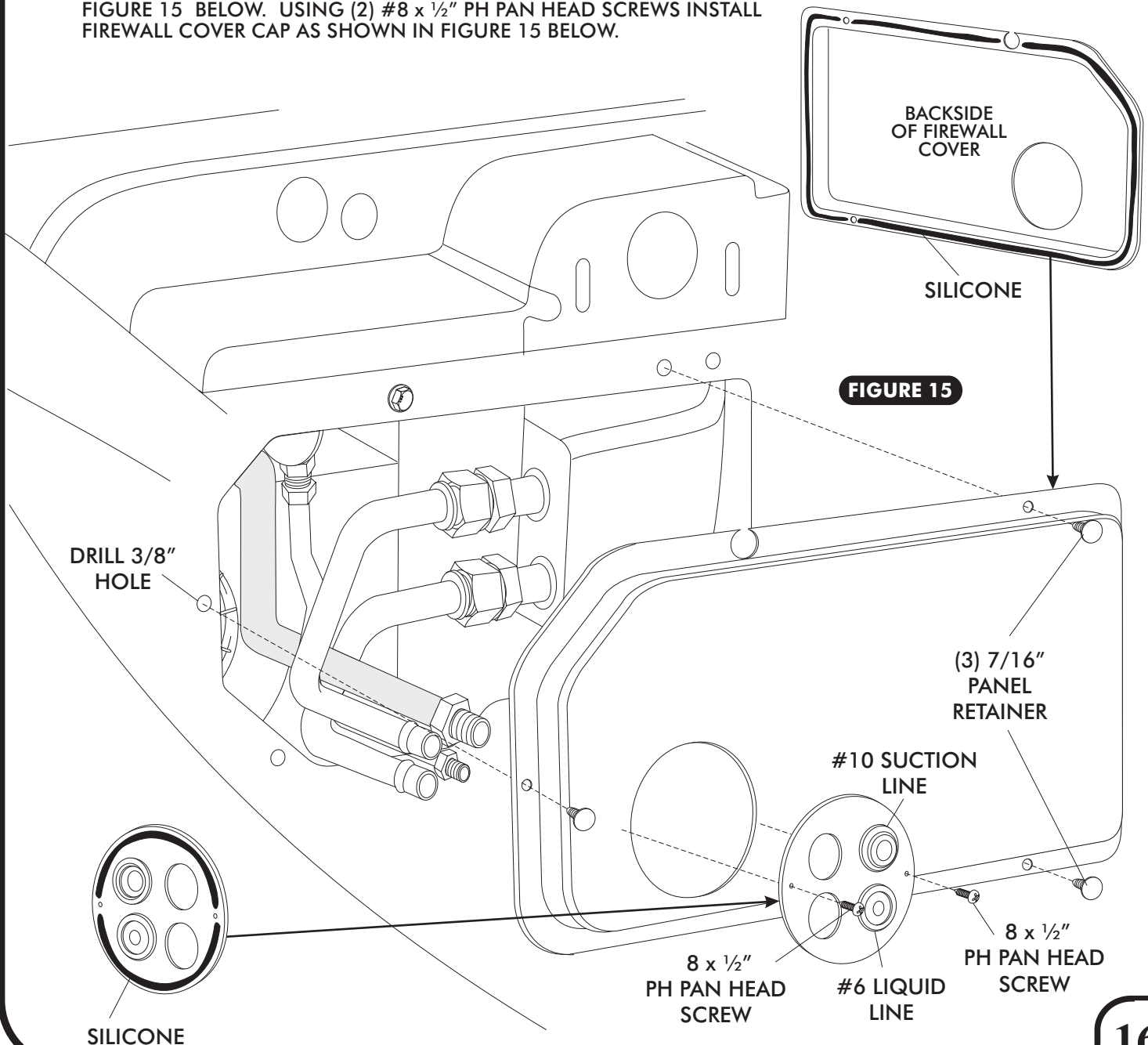



A/C HOSE INSTALLATION STANDARD HOSE KIT

- ❑ LOCATE THE #8 COMPRESSOR A/C HOSE. LUBRICATE (2) #8 O-RINGS (SEE FIGURE 16 BELOW) AND CONNECT THE 90° FITTING TO THE #8 DISCHARGE PORT ON THE COMPRESSOR AND ROUTE THE STRAIGHT FITTING TO THE #8 CONDENSER HARDLINE COMING THROUGH THE CORE SUPPORT SEE FIGURE 18, PAGE 18. TIGHTEN EACH FITTING CONNECTION AS SHOWN IN FIGURE 17 BELOW.
- ❑ LOCATE THE #10 COMPRESSOR A/C HOSE. LUBRICATE (2) #10 O-RINGS (SEE FIGURE 16 BELOW) AND CONNECT THE 135° FITTING TO THE #10 SUCTION PORT ON THE COMPRESSOR AND ROUTE THE STRAIGHT FITTING TO THE #10 EVAPORATOR HARDLINE COMING THROUGH THE FIREWALL SEE FIGURE 18, PAGE 18. TIGHTEN EACH FITTING CONNECTION AS SHOWN IN FIGURE 17 BELOW. **(NOTE: WRAP THE #10 FITTING CONNECTIONS AT FIREWALL WITH PRESS TAPE. SEE FIGURE 18, PAGE 18.)**

MODIFIED A/C HOSE KIT

- ❑ REFER TO SEPARATE INSTRUCTIONS INCLUDED WITH MODIFIED HOSE KIT.

BIG BLOCK MODIFIED HOSE KIT

- ❑ LOCATE THE #8 COMPRESSOR A/C HOSE. LUBRICATE (2) #8 O-RINGS (SEE FIGURE 16 BELOW) AND CONNECT THE 90° FITTING TO THE #8 DISCHARGE PORT ON THE COMPRESSOR AND ROUTE THE STRAIGHT FITTING TO THE #8 CONDENSER HARDLINE COMING THROUGH THE CORE SUPPORT SEE FIGURE 19, PAGE 19. TIGHTEN EACH FITTING CONNECTION AS SHOWN IN FIGURE 17 BELOW.
- ❑ LOCATE THE #10 COMPRESSOR A/C HOSE. LUBRICATE (2) #10 O-RINGS (SEE FIGURE 16 BELOW) AND CONNECT THE 90° FITTING TO THE #10 SUCTION PORT ON THE COMPRESSOR AND ROUTE THE STRAIGHT FITTING TO THE #10 EVAPORATOR HARDLINE COMING THROUGH THE FIREWALL SEE FIGURE 19, PAGE 19. TIGHTEN EACH FITTING CONNECTION AS SHOWN IN FIGURE 17 BELOW. **(NOTE: WRAP THE #10 FITTING CONNECTIONS AT FIREWALL WITH PRESS TAPE. SEE FIGURE 18, PAGE 18.)**

HEATER HOSE & HEATER CONTROL VALVE INSTALLATION

- ❑ ROUTE A PIECE OF HEATER HOSE FROM THE WATER PUMP TO THE HEATER LINE COMING THROUGH THE FIREWALL AS SHOWN IN FIGURES 20, PAGE 20. SECURE USING HOSE CLAMPS.
- ❑ ROUTE A PIECE OF HEATER HOSE FROM THE INTAKE TO THE HEATER LINE COMING THROUGH THE FIREWALL AS SHOWN IN FIGURES 20, PAGE 20. NOTE: INSTALL HEATER CONTROL VALVE IN-LINE WITH INTAKE MANIFOLD (PRESSURE SIDE) HEATER HOSE, SECURE USING HOSE CLAMPS AS SHOWN IN FIGURE 20 ON PAGE 20. **NOTE PROPER FLOW DIRECTION.**

O-RING INSTALLATION

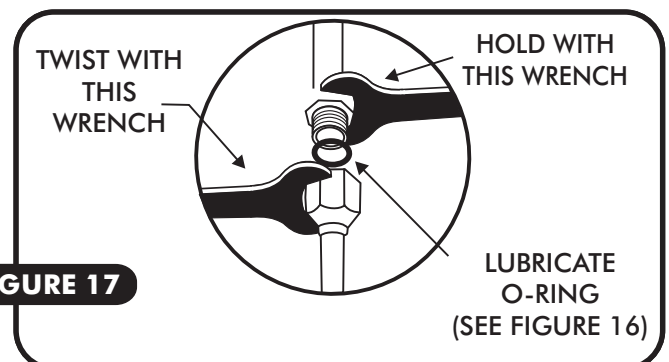
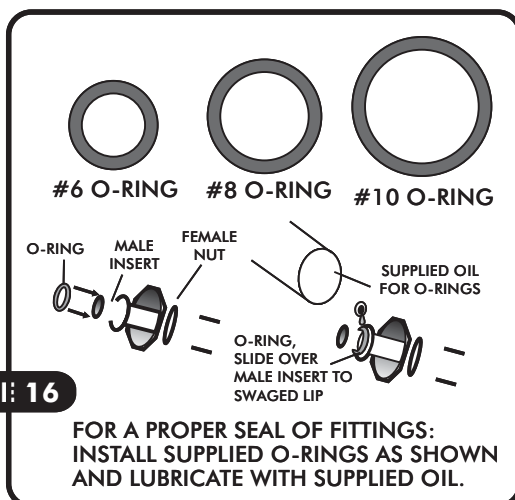



SMALL BLOCK HOSE ROUTING

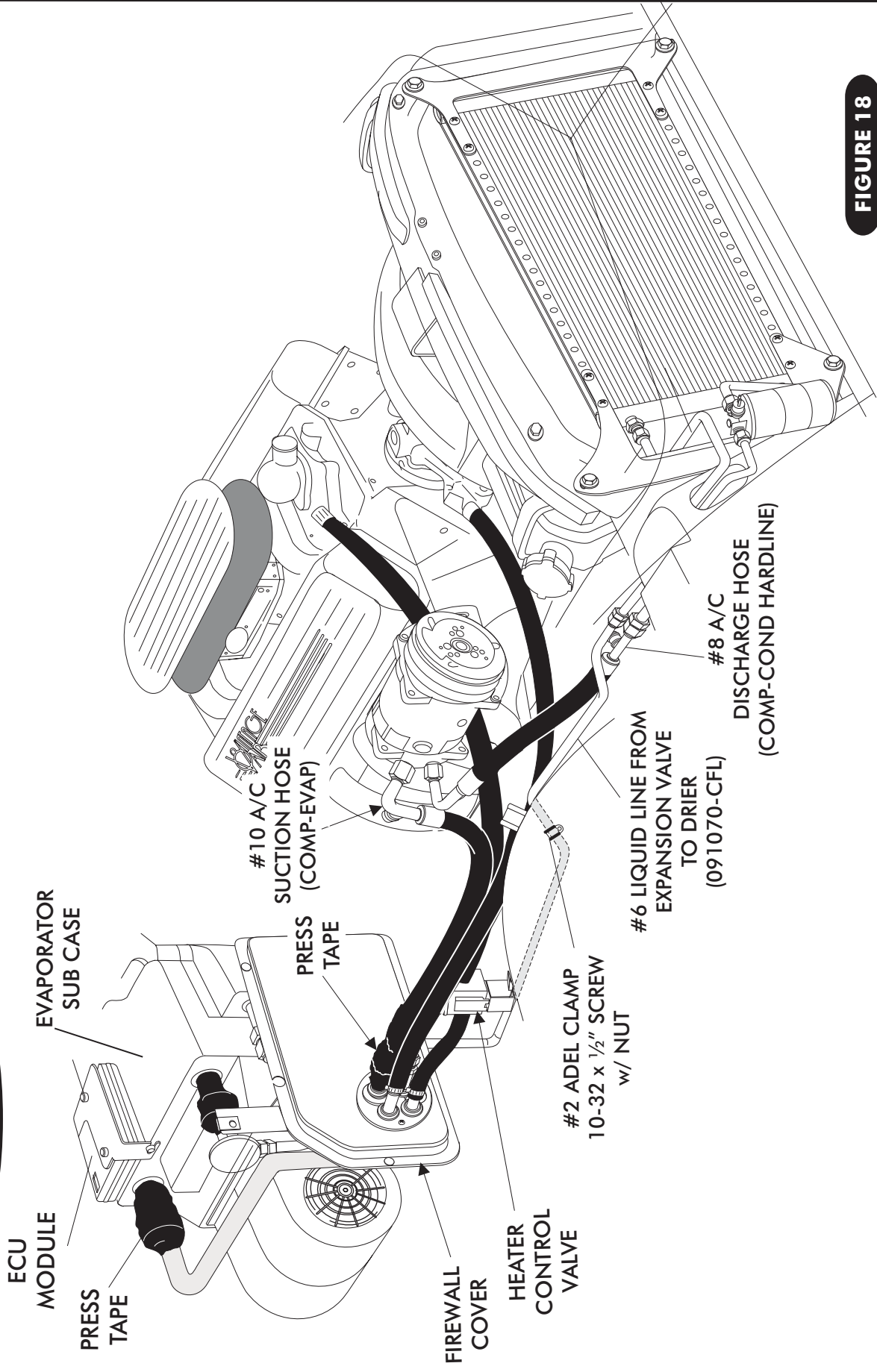

FIGURE 18



BIG BLOCK MODIFIED HOSE ROUTING

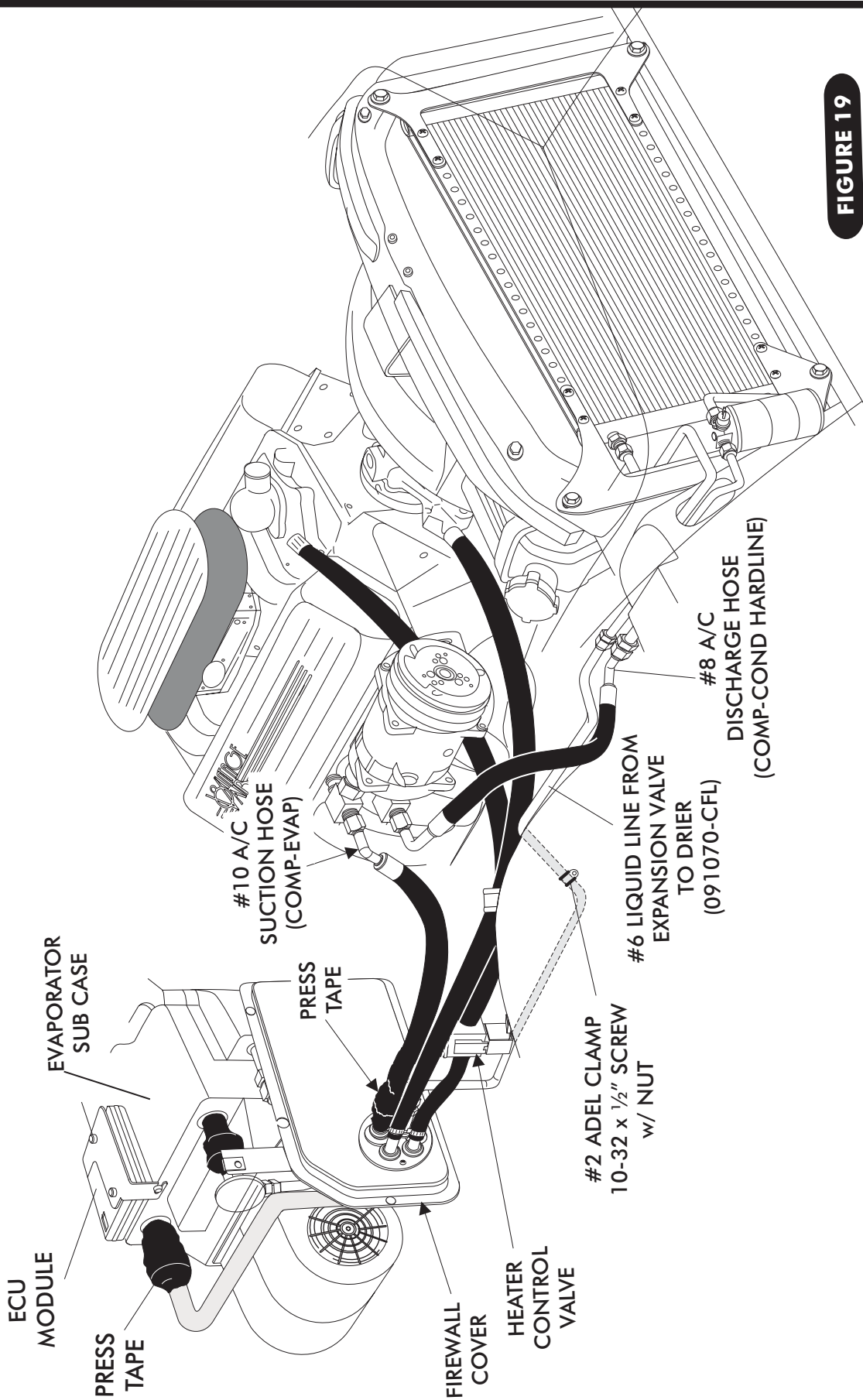

FIGURE 19



HEATER CONTROL VALVE INSTALLATION

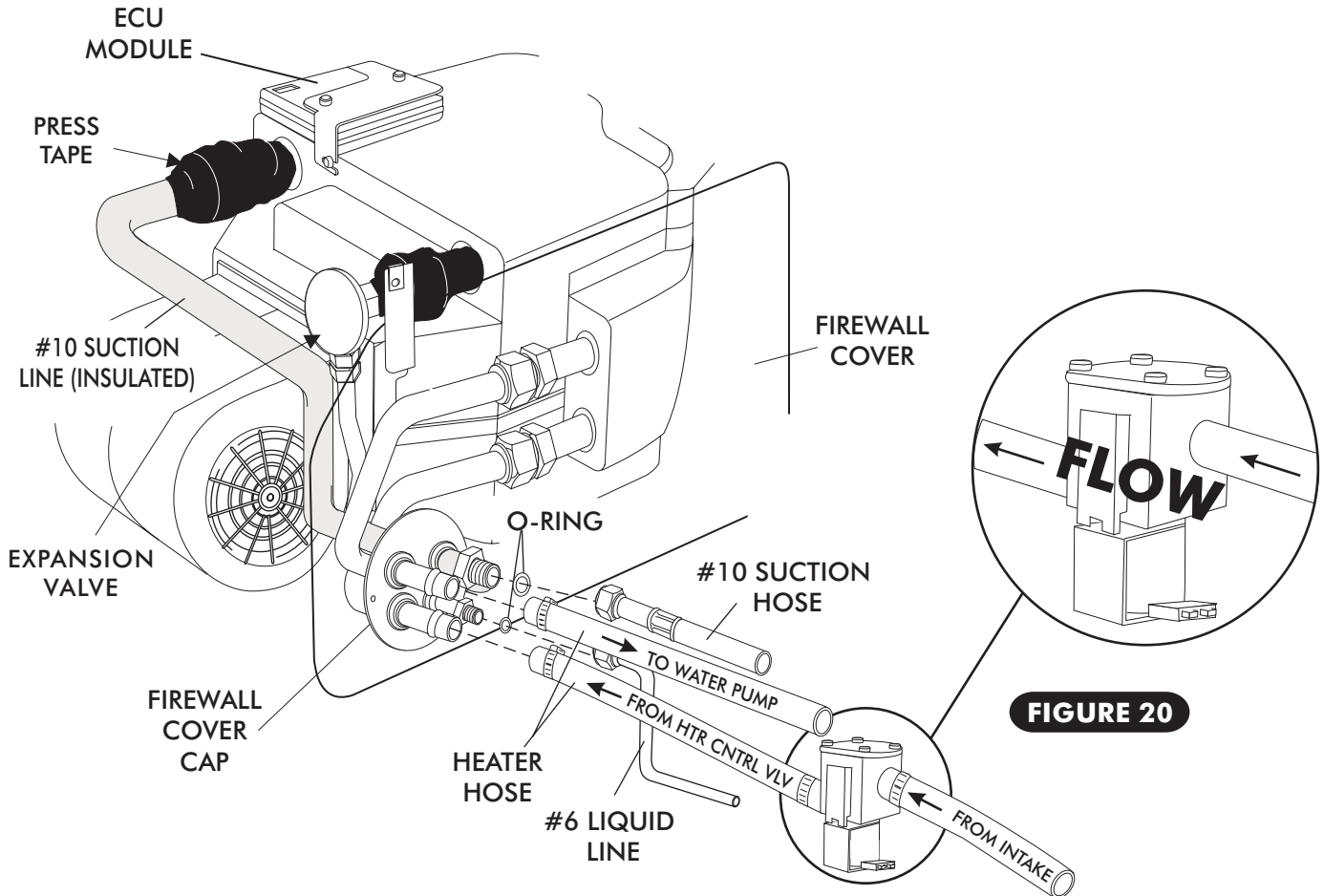

FIGURE 20

FINAL STEPS - DUCT HOSE ROUTING & CONTROL PANEL HARNESS

- INSTALL DUCT HOSES AS SHOWN IN FIGURE 21, PAGE 21.
- REINSTALL THE CENTER DASH ASSEMBLY.
- PLUG THE CONTROL PANEL HARNESS INTO THE ECU MODULE ON SUB CASE AS SHOWN. SEE FIGURE 21, PAGE 21.
- ROUTE THE CONTROL PANEL HARNESS UNDER THE CENTER DASH ASSEMBLY AND CONNECT THE CONTROL HARNESS TO THE CONTROL POTS AS SHOWN IN FIGURE 21, PAGE 21.
- PLUG THE WIRING HARNESS INTO THE ECU MODULE ON SUB CASE AS SHOWN. (WIRE ACCORDING TO WIRING DIAGRAM ON PAGE 23.)
- REINSTALL CONTROL PANEL.
- REINSTALL ALL PREVIOUSLY REMOVED ITEMS (BATTERY BOX & BATTERY).
- FILL RADIATOR WITH AT LEAST A 50/50 MIXTURE OF APPROVED ANTIFREEZE AND DISTILLED WATER. IT IS THE OWNER'S RESPONSIBILITY TO KEEP THE FREEZE PROTECTION AT THE PROPER LEVEL FOR THE CLIMATE IN WHICH THE VEHICLE IS OPERATED. FAILURE TO FOLLOW ANTIFREEZE RECOMMENDATIONS WILL CAUSE HEATER CORE TO CORRODE PREMATURELY AND POSSIBLY BURST IN AC MODE AND/OR FREEZING WEATHER, VOIDING YOUR WARRANTY.
- DOUBLE CHECK ALL FITTINGS, BRACKETS AND BELTS FOR TIGHTNESS.
- VINTAGE AIR RECOMMENDS THAT ALL AC SYSTEMS BE SERVICED BY A CERTIFIED AUTOMOTIVE AIR CONDITIONING TECHNICIAN.
- EVACUATE THE SYSTEM FOR A MINIMUM OF 45 MINUTES PRIOR TO CHARGING AND LEAK CHECK PRIOR TO SERVICING.
- CHARGE THE SYSTEM TO THE CAPACITIES STATED ON THE INFORMATION PAGE (PAGE 4) OF THIS INSTRUCTION MANUAL.



GEN IV 1968-76 CORVETTE w/ AC

CONTROL PANEL & DUCT HOSE ROUTING

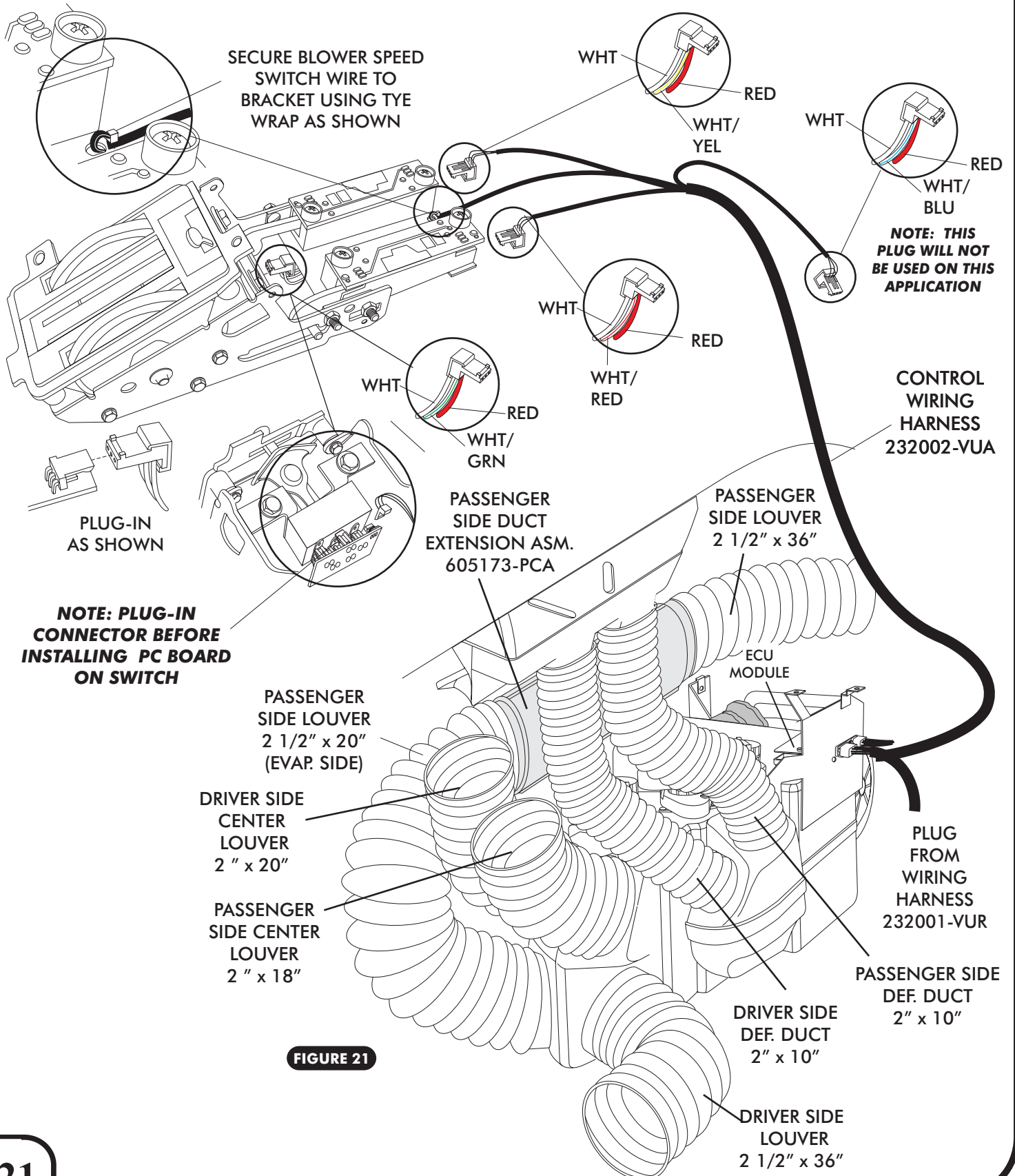

FIGURE 21



GEN IV 1968-76 CORVETTE w/ AC

EVAPORATOR HARD LINE INSTALLATION

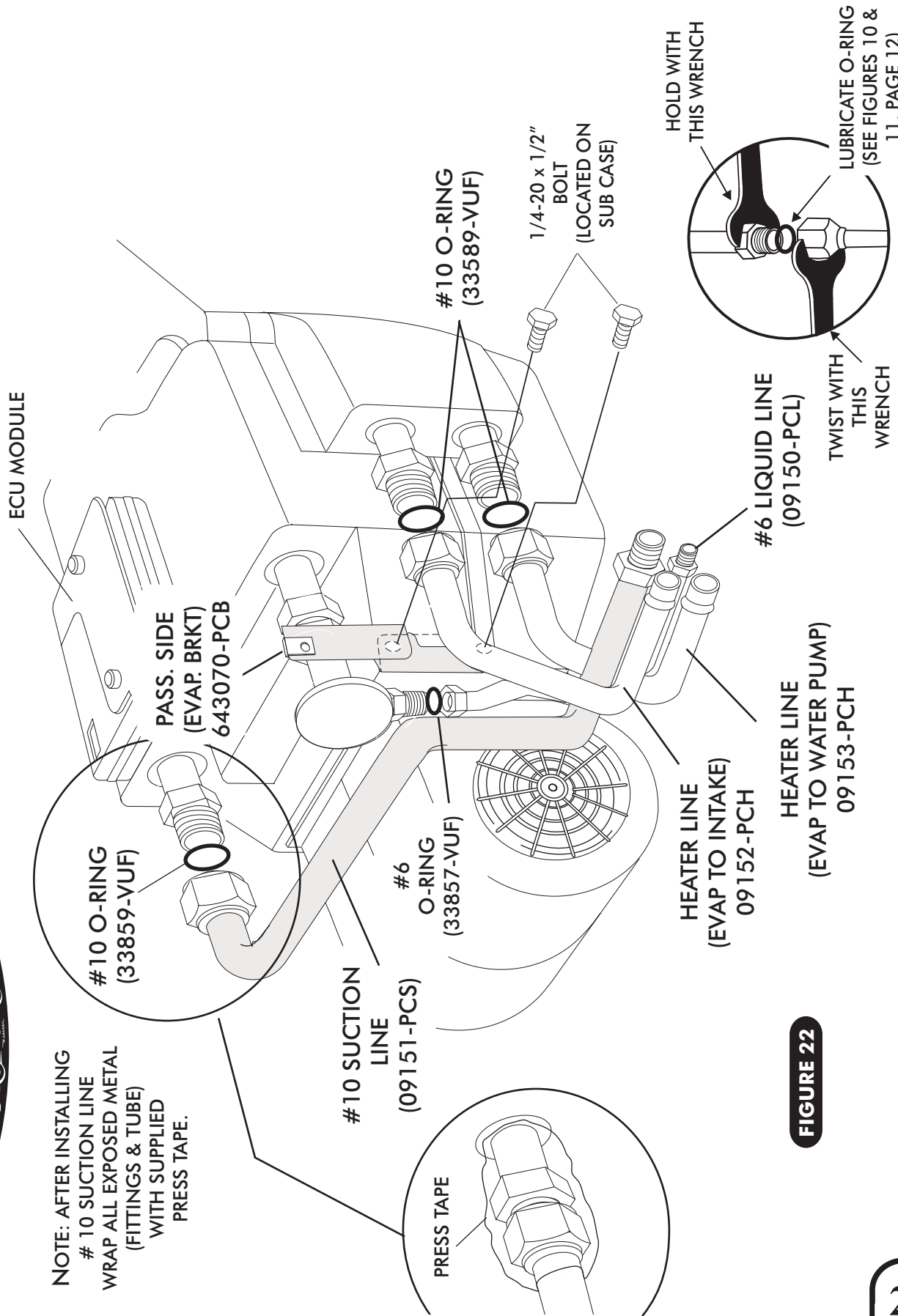

FIGURE 22



GEN IV 1968-76 CORVETTE w/ AC

OPERATION OF CONTROLS

NOTE: WHEN BATTERY POWER IS FIRST CONNECTED TO THE ECU, THE COMPUTER GOES THROUGH AN INITIALIZATION SEQUENCE. THIS INITIALIZATION MAY TAKE UP TO 30 SECONDS. DURING INITIALIZATION THE BLOWER WILL NOT OPERATE, BUT THE DOORS INSIDE THE UNIT WILL BE OPERATING. A LOW BATTERY OR DISCONNECTING THE BATTERY MAY ALSO TRIGGER A RE-INITIALIZATION. DURING START UP, A LOW BATTERY MAY DROP BELOW 7 VOLTS, TRIGGERING RE-INITIALIZATION.

SYSTEM OFF

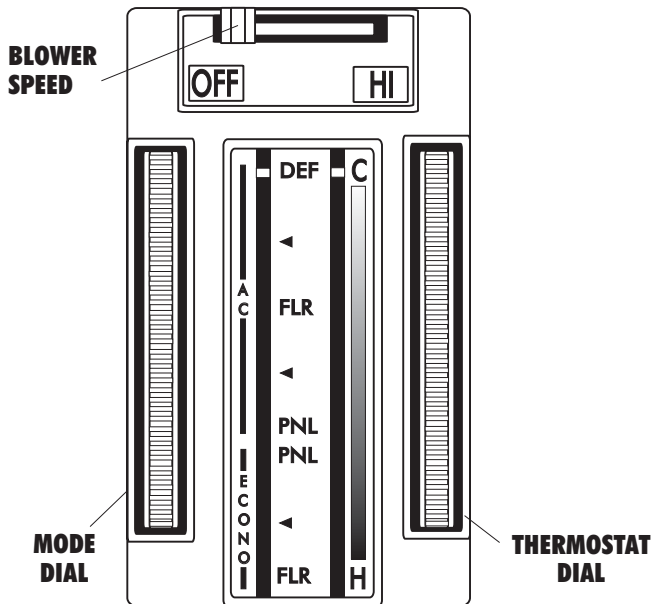

A/C MODE

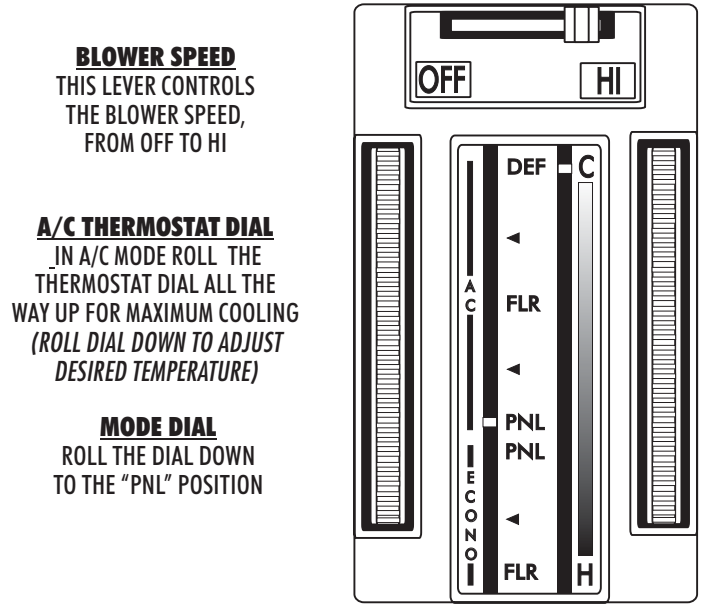

BLOWER SPEED
THIS LEVER CONTROLS THE BLOWER SPEED, FROM OFF TO HI

A/C THERMOSTAT DIAL
IN A/C MODE ROLL THE THERMOSTAT DIAL ALL THE WAY UP FOR MAXIMUM COOLING (ROLL DIAL DOWN TO ADJUST DESIRED TEMPERATURE)

MODE DIAL
ROLL THE DIAL DOWN TO THE "PNL" POSITION

HEAT MODE

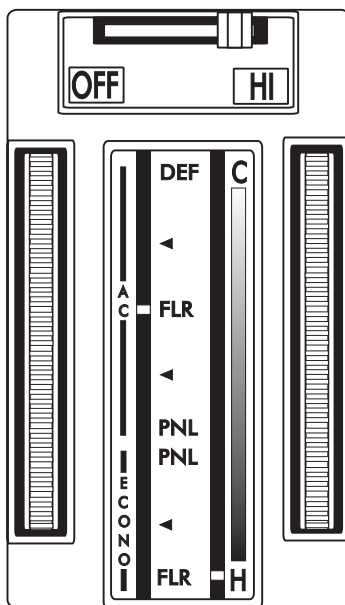

BLOWER SPEED
THIS LEVER CONTROLS THE BLOWER SPEED, FROM OFF TO HI

A/C THERMOSTAT DIAL
IN A/C MODE ROLL THE THERMOSTAT DIAL ALL THE WAY DOWN FOR MAXIMUM HEATING (ROLL DIAL UP TO ADJUST DESIRED TEMPERATURE)

MODE DIAL
ROLL THE DIAL DOWN TO THE "FLR" POSITION (ROLL DIAL UP OR DOWN TO ADJUST DESIRED FLOOR/PNL/DEF LOCATION)

DEFROST MODE

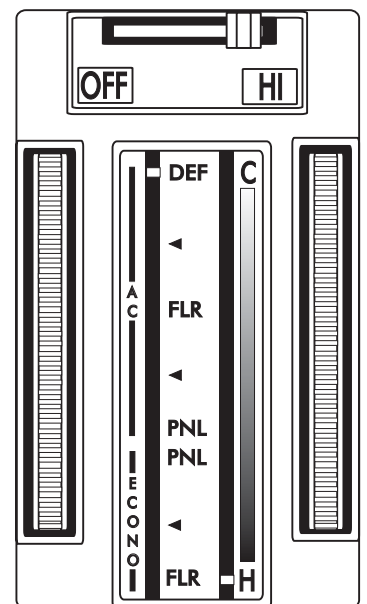

BLOWER SPEED
THIS LEVER CONTROLS THE BLOWER SPEED, FROM OFF TO HI

A/C THERMOSTAT DIAL
IN A/C MODE ROLL THE THERMOSTAT DIAL ALL THE WAY DOWN FOR MAXIMUM HEATING (ROLL DIAL UP TO ADJUST DESIRED TEMPERATURE)

MODE DIAL
ROLL THE DIAL UP TO THE "DEF" POSITION



GEN IV 1968-76 CORVETTE w/ AC

THERMOSTAT ADJUSTMENT

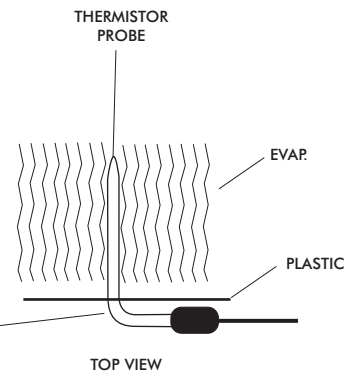
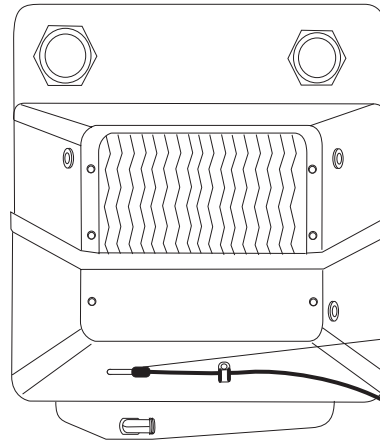
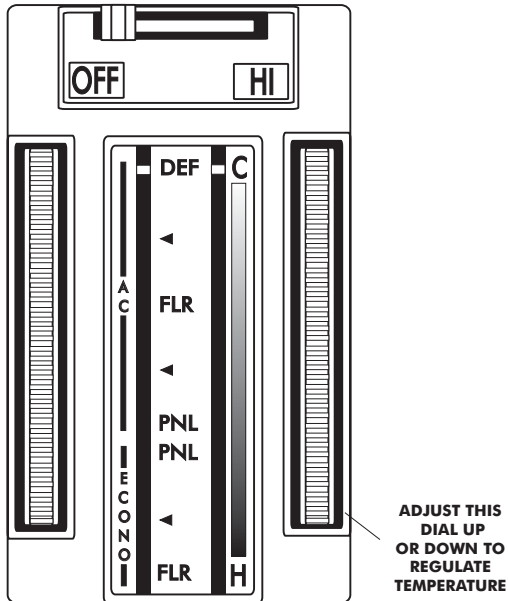

NOTE: GEN IV UNITS DO NOT HAVE A REMOTE THERMOSTAT. THE THERMISTOR PROBE INSTALLED IN THE EVAPORATOR SERVES AS THE THERMOSTAT WHICH IS CONTROLLED BY THE COLD/OFF LEVER ON THE CONTROL PANEL

AIR CONDITIONING ADJUSTMENTS:

- THE AIR CONDITIONER THERMOSTAT LEVER (*COLD LEVER*) CONTROLS COIL TEMPERATURE.
- ADJUSTING THE LEVER UP MAKES THE SYSTEM OPERATE COLDER. IF THE THERMOSTAT LEVER IS SET TOO COLD THE EVAPORATOR MAY "ICE UP" UNDER HIGH HUMIDITY CONDITIONS- THE EVAPORATOR COIL IS RESTRICTED WITH ICE AND COLD AIR FLOW WILL BE REDUCED.
- ADJUSTING THE LEVER DOWN MAKES THE SYSTEM OPERATE WARMER. THE COMPRESSOR CLUTCH WILL CYCLE MORE FREQUENTLY AND THE A/C SYSTEM WILL NOT GET AS COOL AS IT COULD.
- OPTIMUM PERFORMANCE WILL BE ATTAINED WITH THE THERMOSTAT ADJUSTED AS COLD AS POSSIBLE WITHOUT "ICING UP" THE COIL AND THEN USING THE TEMP/BLEND LEVER (*OFF/HEAT*) TO ADJUST VENT TEMPERATURE.

ADJUSTING A/C THERMOSTAT

- 1.) SYMPTOM: THE A/C WORKS WELL AT FIRST THEN QUITS COOLING. THE AIR FLOW FROM THE VENTS IS LOW AND THE COMPRESSOR CYCLES INFREQUENTLY.
SOLUTION: THE THERMOSTAT LEVER IS SET TOO COLD, THE EVAPORATOR IS "ICING UP" AND RESTRICTING AIR FLOW. ALLOW THE ICE TO MELT BY MOVING THE THERMOSTAT LEVER DOWNWARD (WARMER) IN INCREMENTS OF 10% UNTIL SYMPTOMS DIMINISH.
- 2.) SYMPTOM: A/C NEVER GETS COLD AND THE COMPRESSOR CLUTCH CYCLES FREQUENTLY.
SOLUTION: THE THERMOSTAT LEVER IS SET TOO WARM. ADJUST THE THERMOSTAT LEVER UPWARD (COLDER) IN INCREMENTS OF 10% UNTIL THE COMPRESSOR CLUTCH CYCLES INFREQUENTLY. AVOID SETTING THE THERMOSTAT LEVER TOO COLD.



— TROUBLE SHOOTING — INFORMATION

SYMPTOM

- BLOWER STAYS ON HIGH, NO MODE FUNCTIONS
- PARTIAL FUNCTION OF CONTROL HEAD. (SOME FUNCTIONS WORK)
- COMPRESSOR DOES NOT TURN ON. (ALL OTHER FUNCTIONS WORK)
- NO FUNCTION AT ALL

SOLUTION

- BE SURE CONTROL HEAD CONNECTOR IS PROPERLY INSTALLED
- CHECK FOR DAMAGE TO CONTROL HARNESS
- CHECK FOR PROPER CHARGE
- BE SURE AC LEVER (SECOND FROM LEFT) IS UP.
- CHECK MAIN POWER LEAD AFTER CIRCUIT BREAKER
- CHECK FOR POWER WITH IGNITION ON AT PURPLE WIRE
- CHECK ALL GROUNDS



DEFROST DUCT TEMPLATE

CUT OUT TEMPLATE AND TAPE TOGETHER AS SHOWN BELOW.

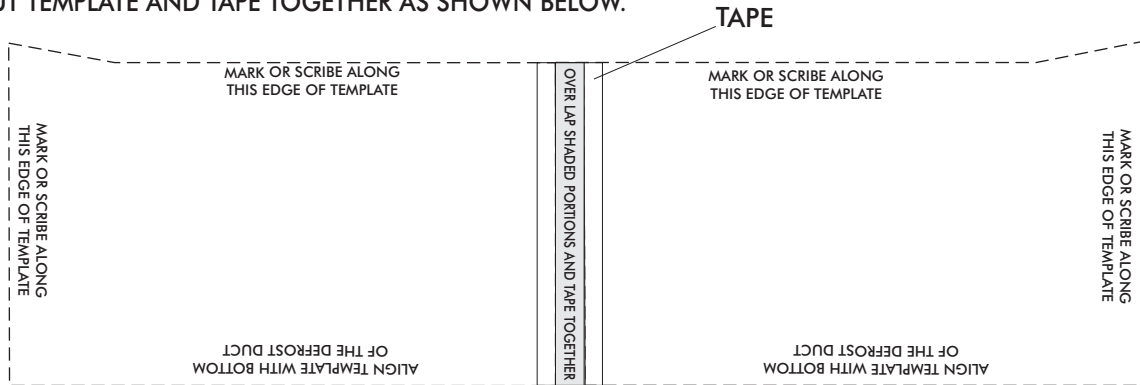

OVER LAP SHADED PORTIONS AND TAPE TOGETHER

CUT ALONG DOTTED LINE

MARK OR SCRIBE ALONG THIS EDGE OF TEMPLATE

ALIGN TEMPLATE WITH BOTTOM OF THE DEFROST DUCT

MARK OR SCRIBE ALONG THIS EDGE OF TEMPLATE

ALIGN TEMPLATE WITH BOTTOM OF THE DEFROST DUCT

MARK OR SCRIBE ALONG THIS EDGE OF TEMPLATE

CUT ALONG DOTTED LINE





GEN IV 1968-76 CORVETTE w/ AC

EVAPORATOR KIT PACKING LIST

EVAPORATOR KIT 564173-PCZ

No.	QTY.	PART No.	DESCRIPTION
1.	1	764173-VCE	1968-76 CORVETTE w/ AC EVAP. SUBCASE
2.	1	784173-PCF	1968-76 CORVETTE w/ AC ACC. KIT

CHECKED BY: _____
 PACKED BY: _____
 DATE: _____

①

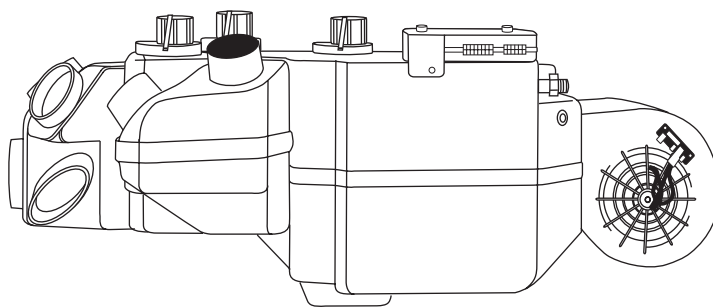

**1968-76 CORVETTE
w/ AC EVAP. SUB CASE
764173-VCE**

②

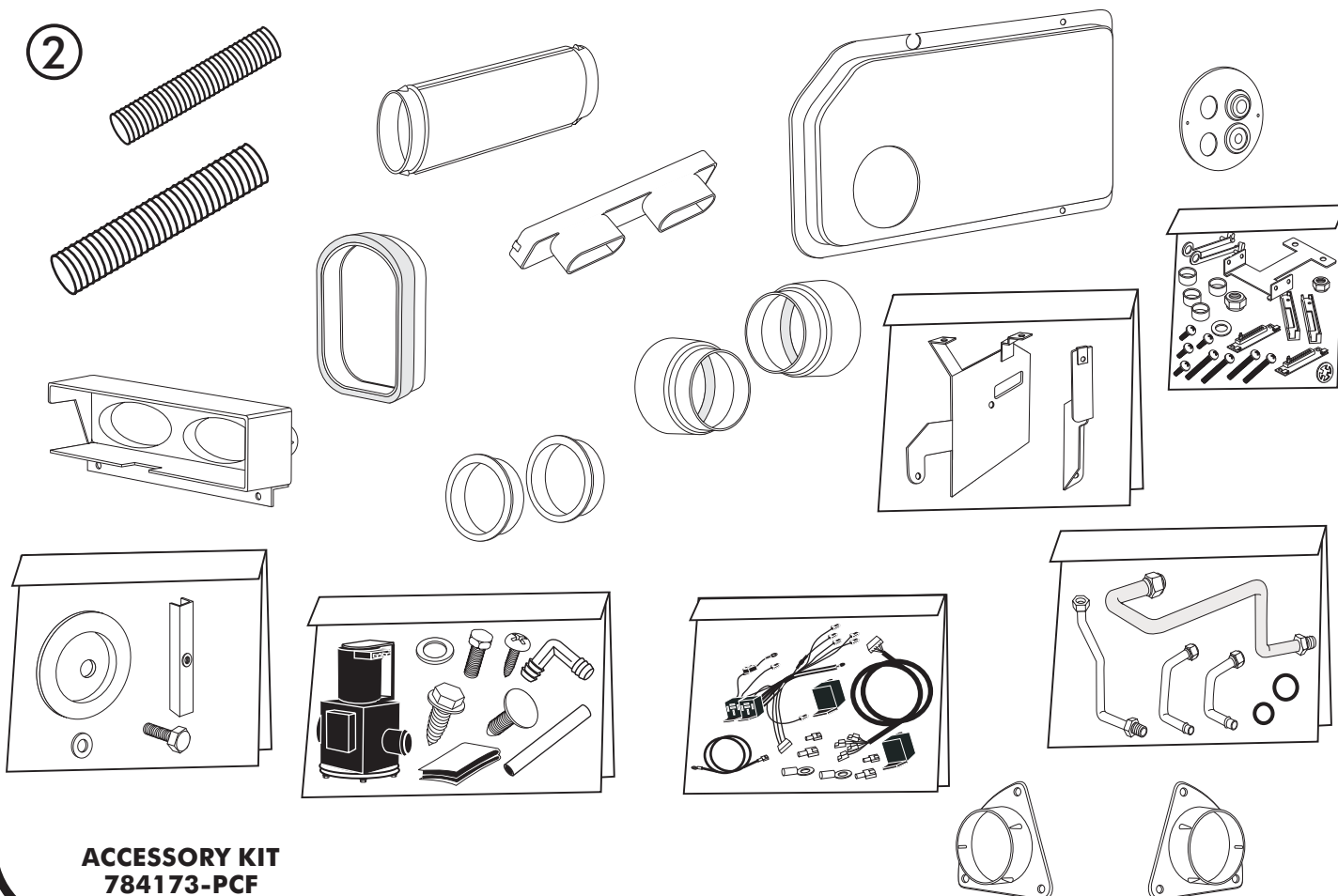

**ACCESSORY KIT
784173-PCF**



GEN IV 1968-76 CORVETTE w/ AC

ACCESSORY KIT PACKING LIST

**ACCESSORY KIT
784173-PCF**

No.	QTY.	PART No.	DESCRIPTION
1.	5	06200-VUE	2" DUCT HOSE
2.	8	06250-VUE	2 1/2" DUCT HOSE
3.	2	625070-CCE	1968-76 CORVETTE O.E.M. DS/PS INNER HA
4.	1	625068-CCA	1968-76 CORVETTE O.E.M. CENTER LOUVER ASM
5.	2	65980-VUE	"S" CLIP
6.	1	625073-CCE	1968-76 CORVETTE DEF DUCT HA
7.	1	627069-CCE	1968-76 CORVETTE FIREWALL COVER
8.	1	627070-CCE	1968-76 CORVETTE FIREWALL COVER CAP
9.	1	33137-VUI	LARGE GROMMET
10.	1	33135-VUI	1 1/4" x 1" w/ 3/8" HOLE GROMMET
11.	1	605173-PCA	1968-76 CORVETTE PS EXTENSION DUCT ASM.
12.	1	634173-PCA	1968-76 CORVETTE w/ AC IK KIT
13.	1	09155-PCA	HARDLINE KIT
14.	1	644173-PCA	1968-76 CORVETTE EVAP BRKT KIT
15.	1	640164-PCA	FRESH AIR CAP ASM
16.	1	473173-PCA	1968-76 CORVETTE CNTRL PNL CONVERSION KIT
17.	1	231055-PCA	GEN IV WIRING KIT
18.	1	625078-CCE	68-76 CORVETTE w/ AC KICK PANEL FRESH AIR CAP
19.	18	201209-OFR	3/8 x 1/2" FOAM STRIP
20.	10	204001-TVR	VELCRO STRIP
21.	1	625079-CCE	1968-76 CORVETTE O.E.M. PS OUTER HA
22.	1	625080-CCE	1968-76 CORVETTE O.E.M. DS OUTER HA
23.	2	33173-VUI	1 1/2" PLUG

CHECKED BY: _____
 PACKED BY: _____
 DATE: _____

