

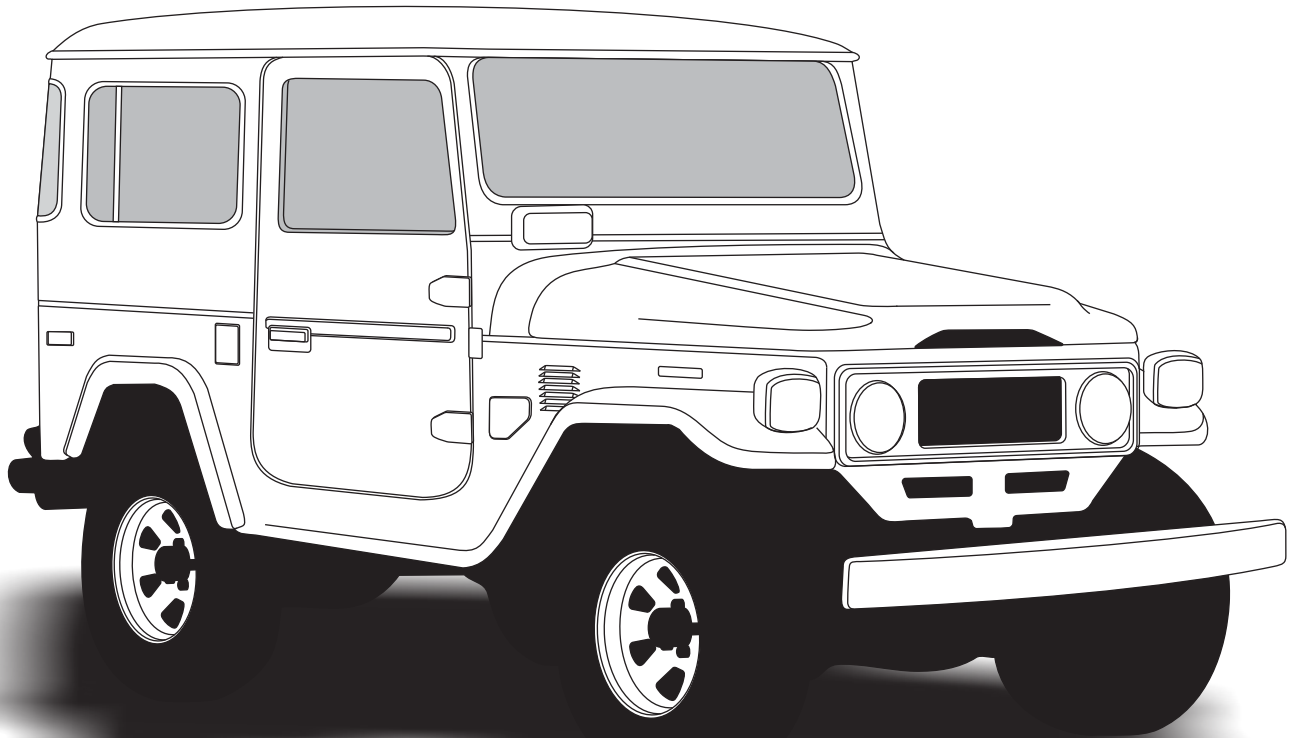

1968-83 TOYOTA LANDCRUISER

2 DOOR/FJ 40
75080-LTZ-A



18865 GOLL ST. - SAN ANTONIO, TX. - 78266 ph.210-654-7171 - fax 210-654-3113



Table of Contents

PAGES

1. COVER
2. TABLE OF CONTENTS
3. PACKING LIST/ PARTS DISCLAIMER
4. INFORMATION PAGE
5. ENGINE COMPARTMENT
FIGURE 1 & 1a
6. CONDENSER INSTALLATION
FIGURES 2, 3, & 4
7. GRILLE EMBLEM ADJUSTMENT
FIGURE 5
EVAPORATOR INSTALLATION
FIGURES 6 & 7
8. EVAPORATOR INSTALLATION CONT.
FIGURES 8-8b
CONTROL CABLES
FIGURES 9 & 10
9. DUCT HOSE INSTALLATION
EVAPORATOR INSTALLATION CONT.
FIGURE 11-11b
10. FIREWALL COVER INSTALLATION
FIGURES 12
AC HOSE INSTALLATION
11. A/C & HEATER HOSE ROUTING
FIGURES 13-13c
12. HEATER HOSE ROUTING
FIGURES 14
DRIVER SIDE VENT INSTALLATION
FIGURE 15
13. OPERATION OF CONTROLS
FIGURE 16
FINAL STEPS
14. WIRING DIAGRAM
15. THERMOSTAT ADJUSTMENT
16. EVAPORATOR KIT PACKING LIST



EVAPORATOR KIT PACKING LIST

**EVAPORATOR KIT
75080-LTZ-A**

No.	QTY.	PART No.	DESCRIPTION
1.	1	55380-LTE-A	1968-83 TOYOTA LANDCRUISER EVAP. SUBCASE
2.	1	795080	1968-83 TOYOTA LANDCRUISER ACC. KIT

**** BEFORE BEGINNING INSTALLATION OPEN ALL PACKAGES AND CHECK CONTENTS OF SHIPMENT. PLEASE REPORT ANY SHORTAGES DIRECTLY TO VINTAGE AIR WITHIN 15 DAYS. AFTER 15 DAYS, VINTAGE AIR WILL NOT BE RESPONSIBLE FOR MISSING OR DAMAGED ITEMS.**

①

**1974-80 TOYOTA
LANDCRUISER
EVAP. SUB CASE
55380-LTE-A**

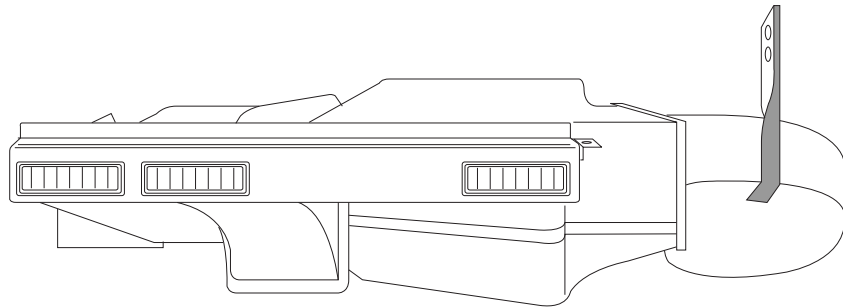

②

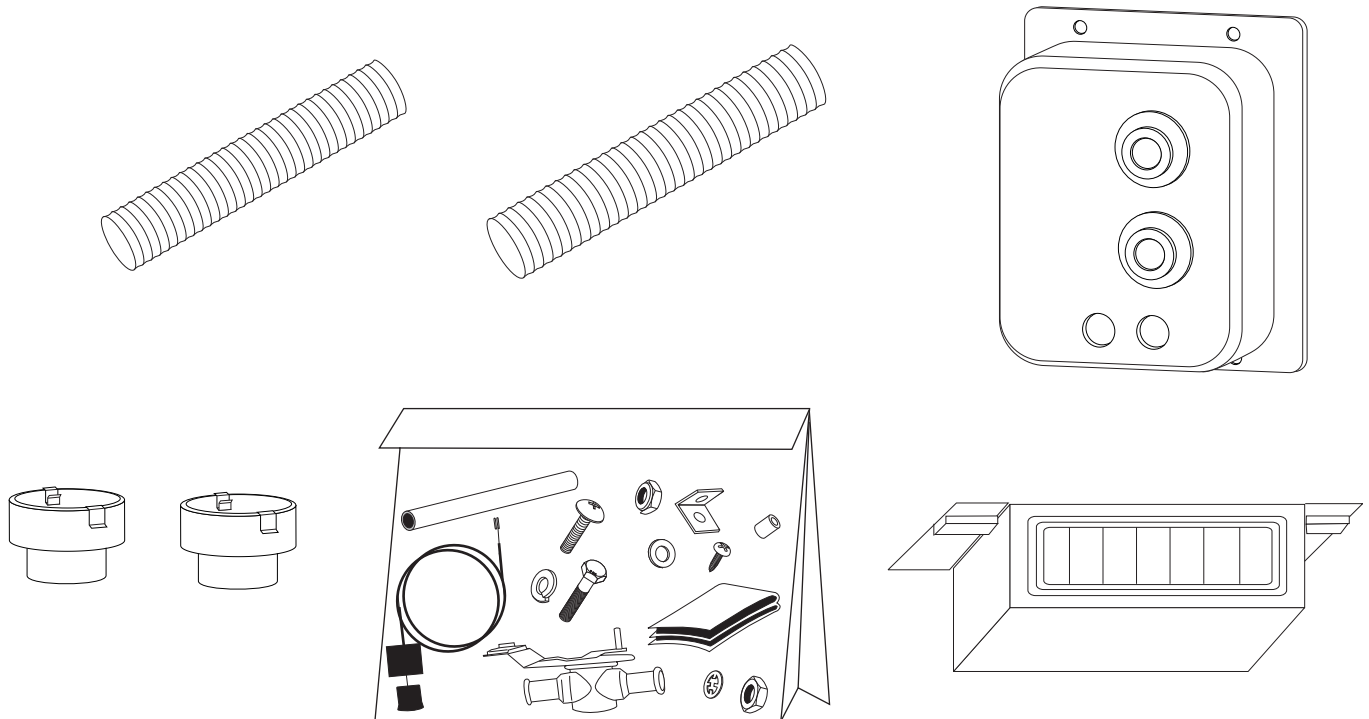

**ACCESSORY KIT
795080**

**NOTE: IMAGES MAY NOT DEPICT ACTUAL PARTS AND QUANTITIES.
REFER TO PACKING LIST FOR ACTUAL PARTS AND QUANTITIES**



1968-83 TOYOTA LANDCRUISER FJ40

1968-83 TOYOTA LANDCRUISER

IMPORTANT NOTICE-PLEASE READ

FOR MAXIMUM SYSTEM PERFORMANCE VINTAGE AIR RECOMMENDS THE FOLLOWING:

THIS KIT DOES NOT CONTAIN HEATER HOSE. YOU MUST PURCHASE 8 FEET OF 5/8" DIA. HEATER HOSE FROM VINTAGE AIR (31800-VUD) OR FROM YOUR LOCAL PARTS RETAILER

SAFETY SWITCHES:

YOUR VINTAGE AIR SYSTEM IS EQUIPPED WITH A BINARY PRESSURE SAFETY SWITCH. A BINARY SWITCH (11078-VUS) DISENGAGES THE COMPRESSOR CLUTCH IN CASE OF EXTREME LOW PRESSURE CONDITION (REFRIGERANT LOSS) OR EXCESSIVELY HIGH HEAD PRESSURE (406 PSI), TO PREVENT COMPRESSOR DAMAGE OR HOSE RUPTURE. A TRINARY SWITCH (11076-VUS) COMBINES HI/LO PRESSURE PROTECTION WITH AN ELECTRIC FAN OPERATION SIGNAL AT 254 PSI., AND MAY BE SUBSTITUTED FOR USE WITH ELECTRIC CONDENSER FANS. COMPRESSOR SAFETY SWITCHES ARE EXTREMELY IMPORTANT SINCE AN A/C SYSTEM RELIES ON REFRIGERANT TO CARRY LUBRICATION THROUGH THE SYSTEM.

SERVICE INFO:

ATTENTION: SYSTEM COMPONENTS: THE COMPRESSOR, EVAPORATOR, CONDENSER & DRIER ARE CAPPED. CAPS MAY BE UNDER PRESSURE WITH DRY NITROGEN; BE CAREFUL REMOVING CAPS. DO NOT REMOVE CAPS PRIOR TO INSTALLATION. REMOVING CAPS PRIOR TO INSTALLATION WILL CAUSE COMPONENTS TO COLLECT MOISTURE AND LEAD TO PREMATURE FAILURE AND REDUCED PERFORMANCE.

EVACUATE THE SYSTEM FOR 35-45 MINUTES WITH SYSTEM COMPONENTS (DRIER, COMPRESSOR, EVAPORATOR AND CONDENSER) AT A TEMPERATURE OF AT LEAST 85° F. ON A COOL DAY THE COMPONENTS CAN BE HEATED WITH A HEAT GUN OR BY RUNNING THE ENGINE WITH THE HEATER ON BEFORE EVACUATING. LEAK CHECK AND CHARGE TO SPECIFICATIONS.

VINTAGE AIR SYSTEMS ARE DESIGNED TO OPERATE WITH R134a or R-12 REFRIGERANT ONLY ! USE OF ANY OTHER REFRIGERANTS RISKS A DANGER OF FIRE AND COULD DAMAGE EITHER YOUR AIR CONDITIONING SYSTEM OR YOUR VEHICLE.

USE OF ANY OTHER REFRIGERANTS WILL VOID ALL WARRANTIES OF THE AIR CONDITIONING SYSTEM AND COMPONENTS. USE OF THE PROPER TYPE AND AMOUNT OF REFRIGERANT IS CRITICAL TO PROPER SYSTEM OPERATION. VINTAGE AIR RECOMMENDS OUR SYSTEMS BE CHARGED BY WEIGHT WITH A QUALITY CHARGING STATION OR SCALE.

REFRIGERANT CAPACITIES FOR VINTAGE AIR SYSTEMS

(FOR OTHER SYSTEMS, CONSULT MANUFACTURER GUIDELINES)

134a SYSTEM

CHARGE WITH 1.8 lbs.
(11bs. 12ozs) OF REFRIGERANT

R-12 SYSTEM

CHARGE WITH 2.0 lbs. OF REFRIGERANT

LUBRICANT CAPACITIES: NEW COMPRESSOR - NO ADDITIONAL OIL NEEDED
USED COMPRESSOR - CONSULT VINTAGE AIR



1968-83 TOYOTA LANDCRUISER FJ40

BEFORE STARTING THE INSTALLATION, CHECK THE FUNCTION OF THE VEHICLE (HORN, LIGHTS, ETC.) FOR PROPER OPERATIONS. STUDY THE INSTRUCTIONS, ILLUSTRATIONS, & DIAGRAMS.

ENGINE COMPARTMENT

REMOVE THE FOLLOWING

- DISCONNECT AND REMOVE BATTERY. RETAIN
- OEM HEATER (DISCARD) SAVE MOUNTING SCREWS.
- HEATER DUCT HOSE
- BLOWER MOTOR AND GRILLE (DISCARD) SAVE MOUNTING SCREWS.
- PLASTIC DUCT (DISCARD)
- HEATER VALVE (DISCARD)
- HEATER HOSES (DISCARD)

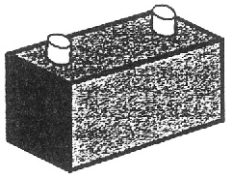

BATTERY

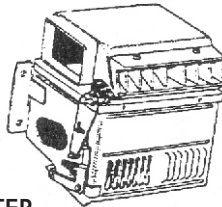

OEM HEATER

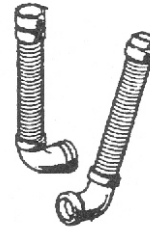

HEATER DUCT HOSE

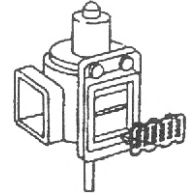

BLOWER MOTOR & GRILLE

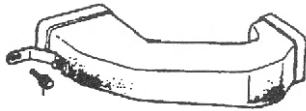

PLASTIC DUCT



HEATER VALVE

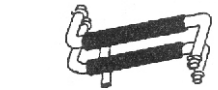

HEATER HOSES

FIGURE 1

COMPRESSOR & BRACKETS

- REFER TO SEPARATE INSTRUCTIONS INCLUDED WITH THE BRACKET KIT TO INSTALL THE COMPRESSOR BRACKET.

PULLEYS

- CHECK ALIGNMENT OF PULLEYS AND FOLLOW THE INSTRUCTIONS PROVIDED WITH THE BRACKET FOR PROPER PULLEY/BELT COMBINATION.

CONDENSER ASSEMBLY & INSTALLATION

**TRUCKS WITH FACTORY AIR SEE NOTE.*

- ROTATE GRILLE ASSEMBLY FORWARD FOR CLEARANCE.
- HOLD THE CONDENSER ASSEMBLY IN PLACE, THE TOP EDGE MUST BE BELOW THE OEM HORIZONTAL BRACE. THE #8 HOSE (PASSENGER SIDE TOP) WILL RUN BETWEEN THE HORN AND THE RADIATOR BRACE. SEE FIGURE 2, PAGE 6.
- LOCATE AND DRILL (4) 9/32" MOUNTING HOLES FOR CONDENSER MOUNTING BRACKET. **SEE NOTE, PAGE 6.**
- SECURE THE CONDENSER WITH (4) 1/4"NC x 1/2" BOLTS, NUTS AND FLAT WASHERS (SUPPLIED).
- LOCATE AND DRILL (2) 3/4" HOLES FOR THE AC LINE CLEARANCE. CUT THE FLANGE TO INSERT CONDENSER HARDLINES. SEE FIGURE 2a, PAGE 6.
- LOCATE O-RING'S, LUBRICATE (2) #6 O-RING'S (SEE FIGURE 1a, BELOW) INSTALL O-RING'S ON THE #6 CONDENSER TO DRIER HARDLINE. INSTALL HARD LINE ON THE LOWER PORT OF CONDENSER. SEE FIGURES 2, 3 AND 4, PAGE 6.

LUBRICATING O-RINGS

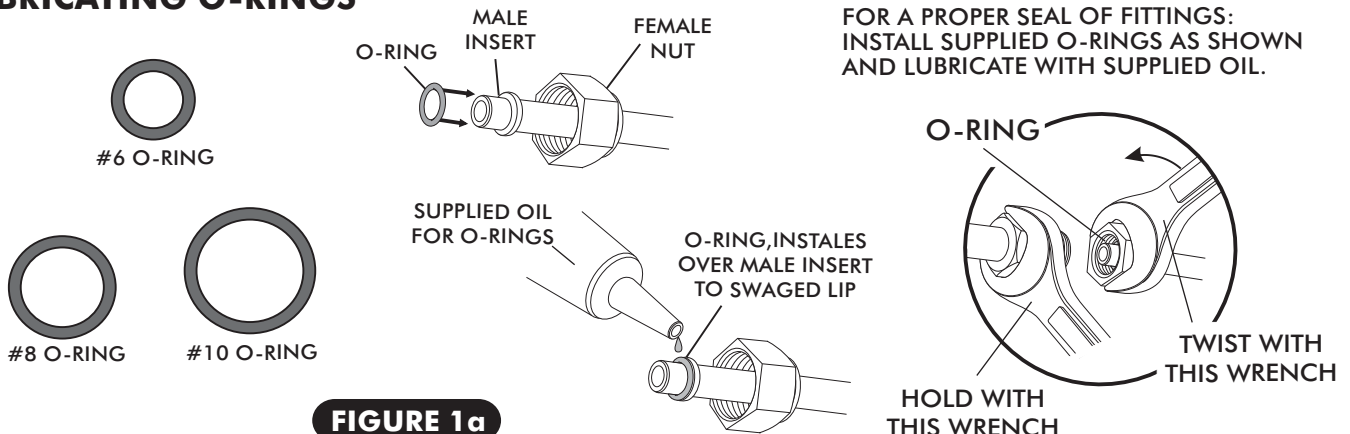

FIGURE 1a



1968-83 TOYOTA LANDCRUISER FJ40

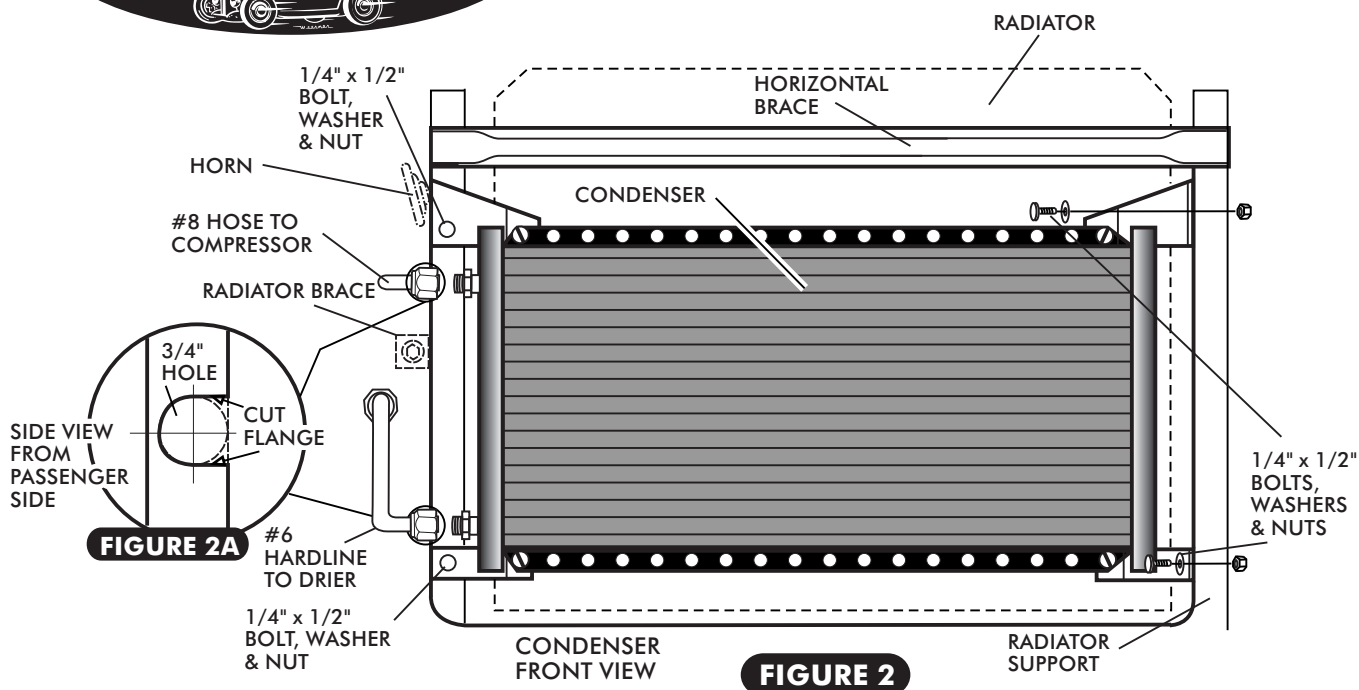

FIGURE 2

***NOTE: TRUCKS WITH FACTORY A/C; USE THE OEM CONDENSER MOUNTING HOLES AND IT IS NOT NECESSARY TO DRILL HOLES FOR A/C HOSE CLEARANCE.**

- MOUNT DRIER ASSEMBLY TO THE BOTTOM (2) FAN SHROUD BOLTS ON THE PASSENGER SIDE. SEE FIGURE 3, BELOW.
- ADJUST THE DRIER IN ITS CLAMPS UNTIL THE #6 HARDLINE FROM THE CONDENSER ALIGNS PROPERLY.
- ATTACH THE #6 HARDLINE WITH LUBRICATED O-RING TO THE DRIER. SEE FIGURE 3, BELOW. TIGHTEN FITTING CONNECTIONS SEE FIGURE 1a, PAGE 5
- LOCATE THE #8 DISCHARGE HOSE THAT RUNS FROM THE CONDENSER TO THE COMPRESSOR. LUBRICATE (2) #8 O-RINGS (SEE FIGURE 1a, PAGE 5) INSTALL O-RINGS ON FITTINGS AND CONNECT THE 90° CONDENSER END TO THE CONDENSER SEE FIGURE 4, BEOW.
- ROUTE THE #8 HOSE BETWEEN THE HORN AND THE RADIATOR SUPPORT BRACKET ON THE PASSENGER SIDE.
- CONNECT THE OPPOSITE END OF DISCHARGE HOSE TO THE #8 DISCHARGE PORT ON THE COMPRESSOR. SEE FIGURE 13, PAGE 11. TIGHTEN FITTING CONNECTIONS SEE FIGURE 1a, PAGE 5

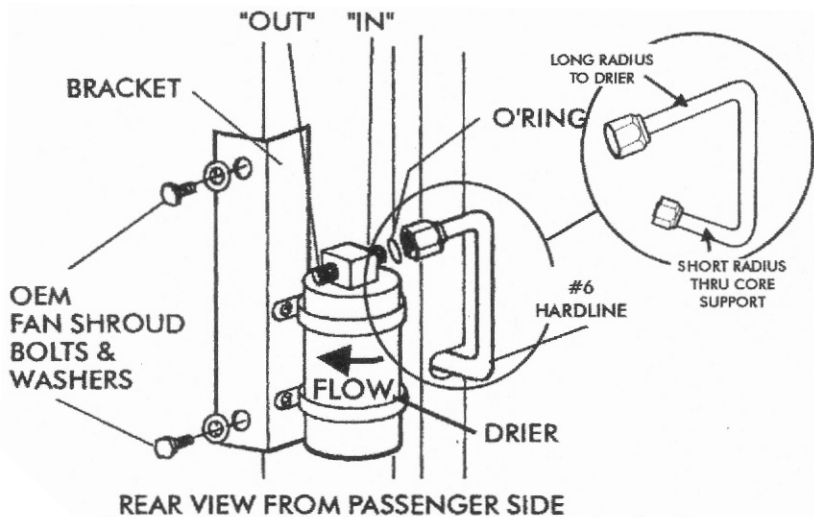

FIGURE 3

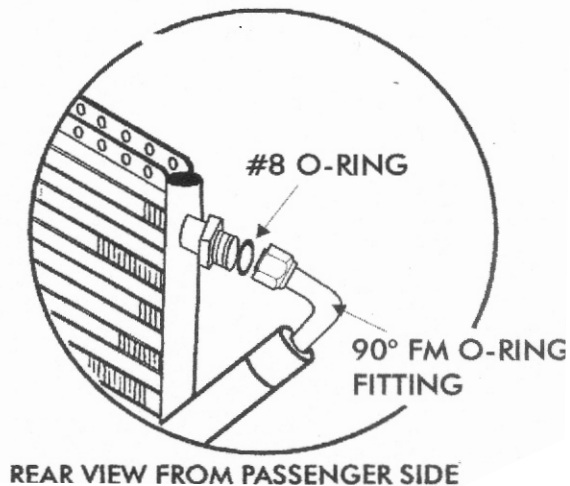

FIGURE 4



GRILLE EMBLEM ADJUSTMENT

- THE TOYOTA GRILLE EMBLEM MUST BE MODIFIED OR IT WILL HIT THE CONDENSER CAUSING IT TO LEAK.
- REMOVE THE EMBLEM AND CUT OFF THE MOUNTING SCREWS FLUSH WITH THE PLASTIC EXTENSION.
- ROUND THE TOP EDGE OF THE PLASTIC EXTENSIONS WITH A FILE. INSERT THE EMBLEM THROUGH THE GRILLE BAR IN THE ORIGINAL LOCATION.
- USE A 7/16", 12 POINT SOCKET, INSTALL THE (2) 3/8" PUSH ON RINGS (THE SPRING TABS GO UP).

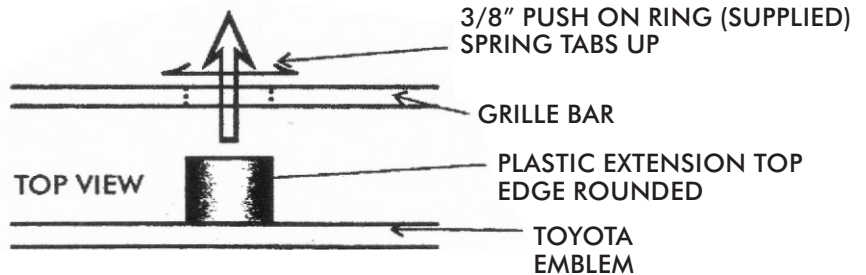

FIGURE 5

EVAPORATOR INSTALLATION

- THE TOP OF COWL VENT ON EARLY (1968) MODELS MUST BE MADE INOPERABLE.

REAR HEATER HOSE INSTALLATION (AS REQUIRED)

- IT'S BEST TO CONNECT THE REAR HEATER HOSES BEFORE INSTALLING THE EVAPORATOR. CUT TWO 24" LONG PIECES OF 5/8" HEATER HOSE. USING HOSE CLAMPS, CONNECT ONE TO EACH LINE ON THE EVAPORATOR. SEE FIGURE 6 BELOW. YOU WILL NEED THREE (3) 90 DEGREE x 5/8" HOSE FITTINGS AND TWO (2) 5/8" "T" FITTINGS TO COMPLETE THE HEATER HOSE ROUTING. ROUTE HOSES AS SHOWN IN FIGURE 14, PAGE 12.

NOTE: ON ALL EVAPORATOR BRACKETS - USE TOP HOLE WITH DASH PADS AND BOTTOM HOLE WITHOUT DASH PADS.

CONNECT HEATER HOSES TO EVAPOTOR - THE HEATER LINES: AIM UP TO ROUTE THROUGH THE LOWER OEM HOLE IN FIREWALL

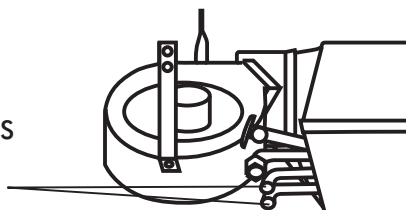

FIGURE 6

LOWER OEM HOLE IN FIREWALL FROM INSIDE

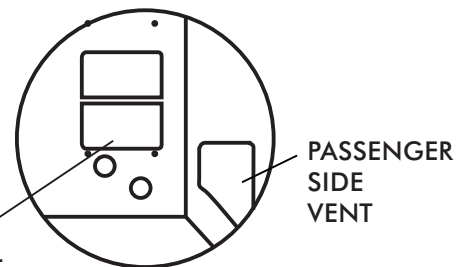
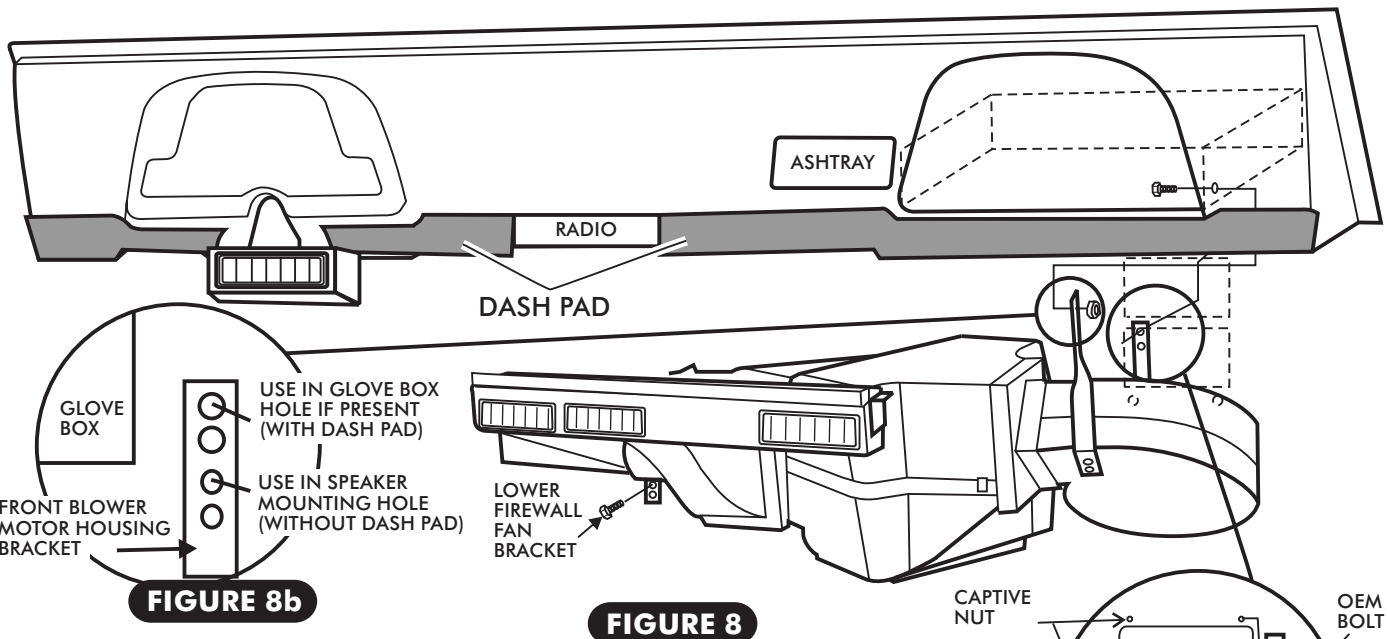

FIGURE 7

- ONCE HOSES ARE CONNECTED, ALIGN THE EVAPORATOR END OF A/C HOSES WITH THE LOWER OEM HOLE IN FIREWALL. SEE FIGURE 7, ABOVE. (SEE A/C HOSE INSTRUCTIONS ON PAGE 11).
- REMOVE FIREWALL SIDE BLOWER MOTOR HOUSING BRACKET FROM THE EVAPORATOR. ATTACH THE BRACKET TO THE TOP PASSENGER SIDE OEM FAN MOUNTING CAPTIVE NUT AS SHOWN IN FIGURE 8a ON PAGE 8. SECURE BRACKET TO THE FIREWALL USING THE OEM BOLT.
- REMOVE FRONT (DASH) BLOWER MOTOR HOUSING BRACKET FROM EVAPORATOR. THE BRACKET HAS 4 HOLES (SEE FIGURE 8b). THE LARGE HOLES ON TOP OF THE BRACKET GO TO THE OEM HOLE JUST INSIDE THE GLOVE BOX DOOR TO THE RIGHT (WHEN AVAILABLE). THE SMALLER HOLES GO TO THE OEM SPEAKER MOUNTING HOLES (WHEN AVAILABLE). CHOOSE APPROPRIATE HOLES FOR YOUR TRUCK.

EVAPORATOR INSTALLATION CONT.



- LAY EVAPORATOR UNDER DASH AND ROUTE HEATER HOSES THROUGH THE LOWER OEM HOLE IN FIREWALL. SEE FIGURE 7, PAGE 7.
- AT THIS TIME, ONLY CONNECT THE FIREWALL SIDE BLOWER HOUSING BRACKET TO THE EVAPORATOR.
- USING THE TOP HOLE IN LOWER FIREWALL BRACKET, INSTALL LOWER FIREWALL BRACKET IN THE OEM HEATER HOLE LOCATION IN FIREWALL. SECURE BRACKET TO FIREWALL USING THE OEM BOLT. SEE FIGURE 8.
 -AT THIS POINT THE EVAPORATOR WILL HANG AT AN ANGLE SO THE WIRING, DUCTS, AND CABLES CAN BE INSTALLED.
 -ADDITIONAL ACCESS CAN BE MADE THROUGH THE RADIO AND ASHTRAY OPENINGS.

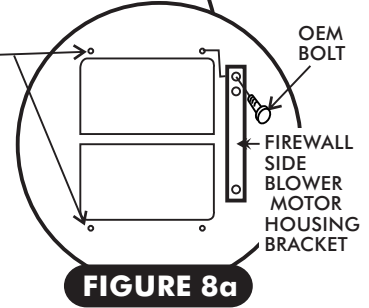

CONTROL CABLES

- CONNECT CONTROL CABLES. SEE FIGURES 9&10, BELOW. SEE FIGURE 16, PAGE 13 FOR OPERATION OF CONTROLS.
- CHECK CABLES FOR FULL TRAVEL.

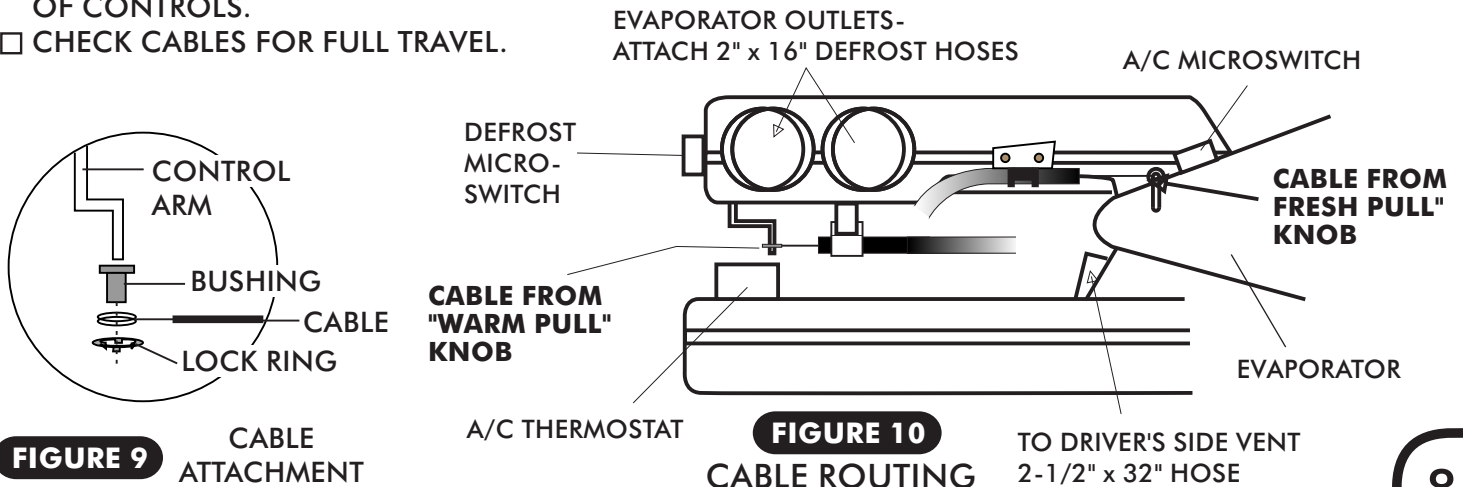

FIGURE 9 CABLE ATTACHMENT

FIGURE 10 CABLE ROUTING TO DRIVER'S SIDE VENT 2-1/2" x 32" HOSE

DUCT HOSE INSTALLATION

- ❑ CONNECT THE DRIVER'S SIDE VENT DUCT HOSE (2-1/2" x 32") TO THE EVAPORATOR.
- ❑ ATTACH DEFROST HOSE ADAPTERS TO OEM DEFROST VENTS BY PRESSING FIRMLY OVER "S"-CLIPS. SEE FIGURE 11a.
- ❑ ATTACH A 2" x 16" DEFROSTER DUCT HOSE TO EACH EVAPORATOR OUTLET AND DEFROST HOSE ADAPTER. SEE FIGURE 11a, BELOW.

EVAPORATOR INSTALLATION (CONTINUED)

- ❑ **TRUCKS WITHOUT OEM DASH PADS** - REMOVE DASH PAD SPACER ON THE EVAPORATOR SEE FIGURE 11 & 11B, BELOW. THE NYLON SPACERS ON BOTH SIDES WILL NOT BE NEEDED.
- ❑ **TRUCKS WITH THE DASH PAD**- THE NYLON SPACERS ARE REQUIRED. DRILL A 5/32" HOLE UP THROUGH THE DASH USING THE HOLE IN THE BRACKET AS A GUIDE. INSTALL THE NYLON BUSHINGS BETWEEN THE DASH AND EVAPORATOR. PASSING THE BOLT THROUGH THE BRACKET, THE NYLON BUSHING, THE DASH. SECURE WITH LOCKNUT. SEE FIGURE 11, BELOW

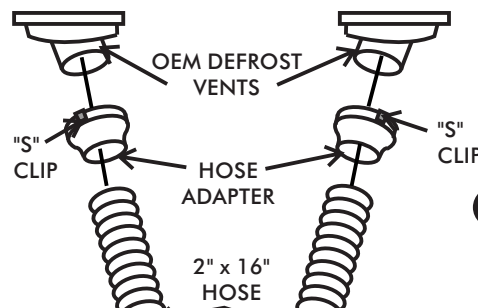

FIGURE 11a

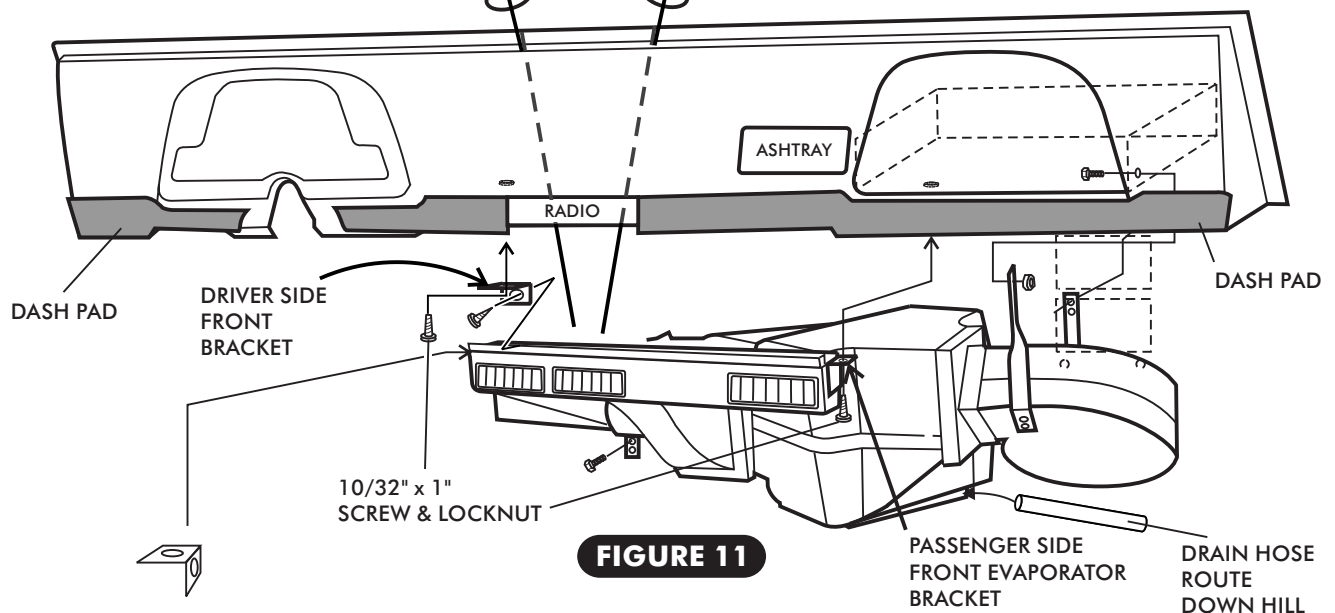

FIGURE 11

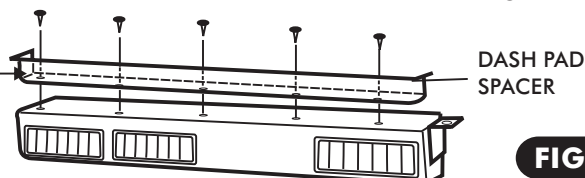

FIGURE 11b

- ❑ **VEHICLES WITHOUT OEM DASH PADS** - REMOVE DASH PAD SPACER (5 METAL SCREWS) AND MOVE THE DRIVER'S SIDE FRONT BRACKET TO THE DRIVER'S SIDE END OF THE EVAPORATOR. SEE FIGURE 11B.



FIREWALL COVER INSTALLATION

- APPLY A 1/4" BEAD OF SILICONE AROUND THE BACKSIDE OF THE FIREWALL COVER AND INSTALL FIREWALL COVER. SEE FIGURE 12.

IT IS IMPORTANT TO USE THE THREE (3) SUPPLIED 8mm - 1.25 PITCH x 25mm BOLTS TO PREVENT DAMAGE TO THE EVAPORATOR AND GLOVE BOX..

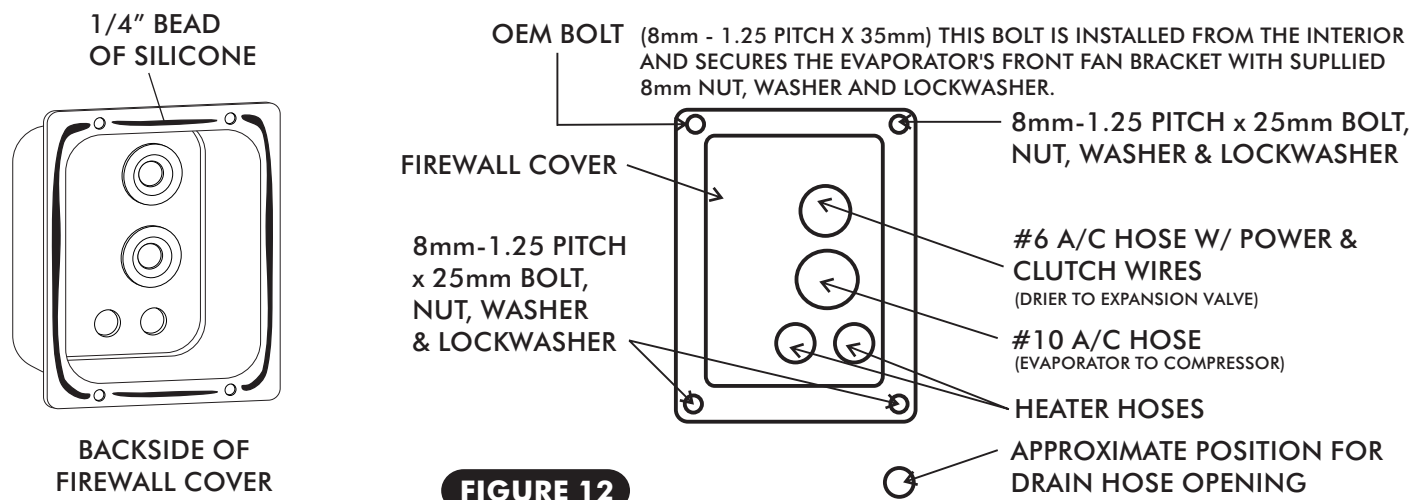

FIGURE 12

- INSTALL DRAIN HOSE AT EVAPORATOR UNIT. LINE UP AND DRILL OPENING IN FIREWALL. BE SURE TO RUN DOWNHILL.

A/C HOSE INSTALLATION

- ALWAYS CONNECT THE EVAPORATOR END OF THE HOSE FIRST AND LEAVE THE ENDS SLIGHTLY LOOSE FOR ALIGNMENT OF THE FITTINGS.
- BEFORE INSTALLATION BLOW OUT ALL THREE RUBBER HOSES WITH DRY AIR AND RECAP.
- LOCATE THE #10 RUBBER AC SUCTION HOSE (LARGE HOSE) THAT RUNS FROM THE EVAPORATOR THROUGH THE FIREWALL COVER TO THE SUCTION SIDE OF THE A/C COMPRESSOR. LUBRICATE THE O-RING'S AS SHOWN IN FIGURE 1a, PAGE 5. CONNECT THE STRAIGHT END TO THE EVAPORATOR AND THE 135° END WITH SERVICE PORT TO THE SUCTION SIDE OF THE COMPRESSOR. BE SURE THERE IS NO INTERFERENCE BETWEEN THE TWO SERVICE PORTS. SEE FIGURE 13 & 13a, PAGE 11.
- LOCATE THE #6 RUBBER AC HOSE (SMALL HOSE). LUBRICATE THE O-RING'S SHOWN IN FIGURE 1a, PAGE 5. RUN HOSE FROM THE EVAPORATOR THROUGH THE FIREWALL COVER TO THE DRIER. THE 45° END CONNECTS TO THE DRIER AND TIPS UP TO CLEAR THE LEFT FRONT SHOCK. SEE FIGURE 13 & 13a, PAGE 11.
- ONCE FITTINGS ARE ALIGNED, TIGHTEN ALL FITTING CONNECTIONS (SEE FIGURE 1a, PAGE 5). USE TWO CLAMP ASSEMBLIES TO SECURE THE #6 AND #10 HOSES. SEE FIGURE 13c.
- THE METAL PARTS OF THE #10 SUCTION HOSE AT THE EVAPORATOR MUST BE COVERED WITH PRESS TAPE TO HELP PREVENT CONDENSATION LEAKS INSIDE THE TRUCK. SEE FIGURE 13b.



A/C HOSE ROUTING

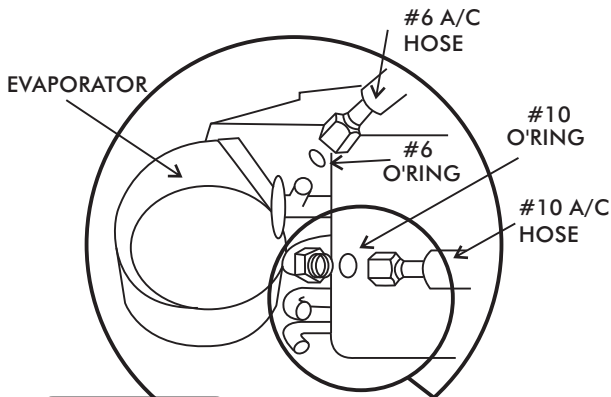

FIGURE 13a

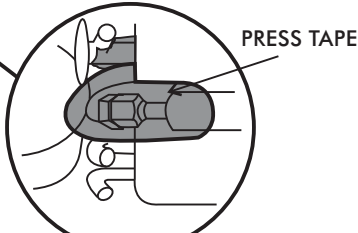
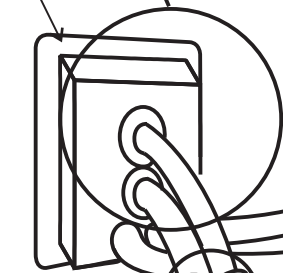

FIGURE 13b

FIREWALL COVER



HEATER HOSES-SEE FIGURE 6 (PG.4)

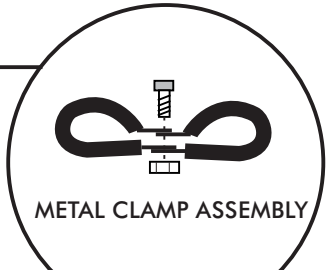
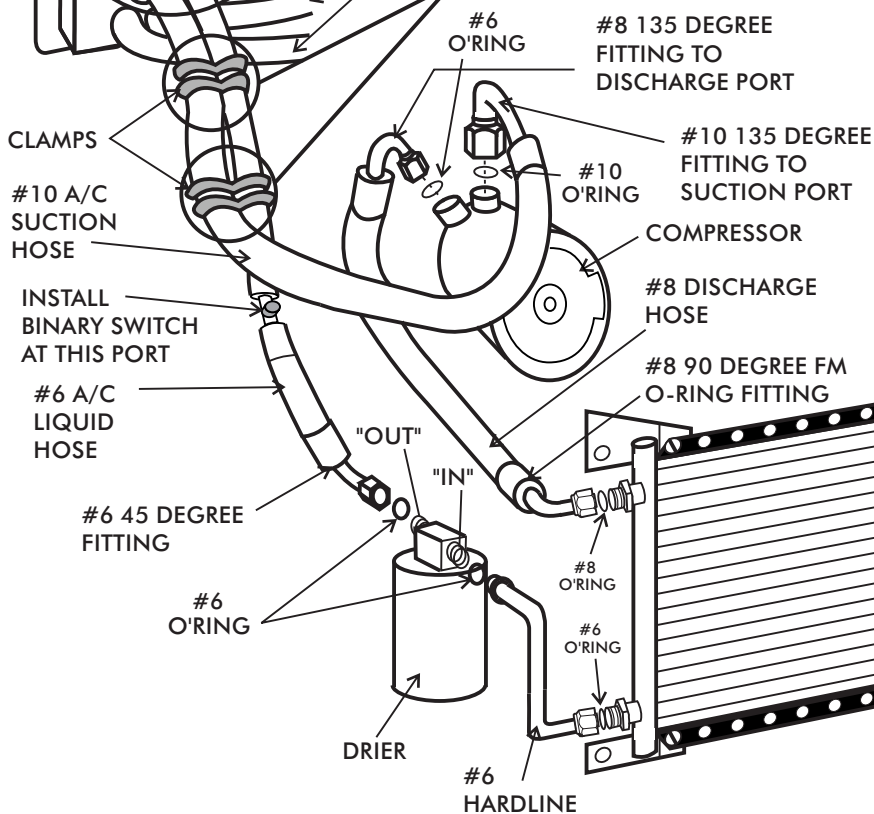

FIGURE 13c

FIGURE 13



HEATER HOSE ROUTING

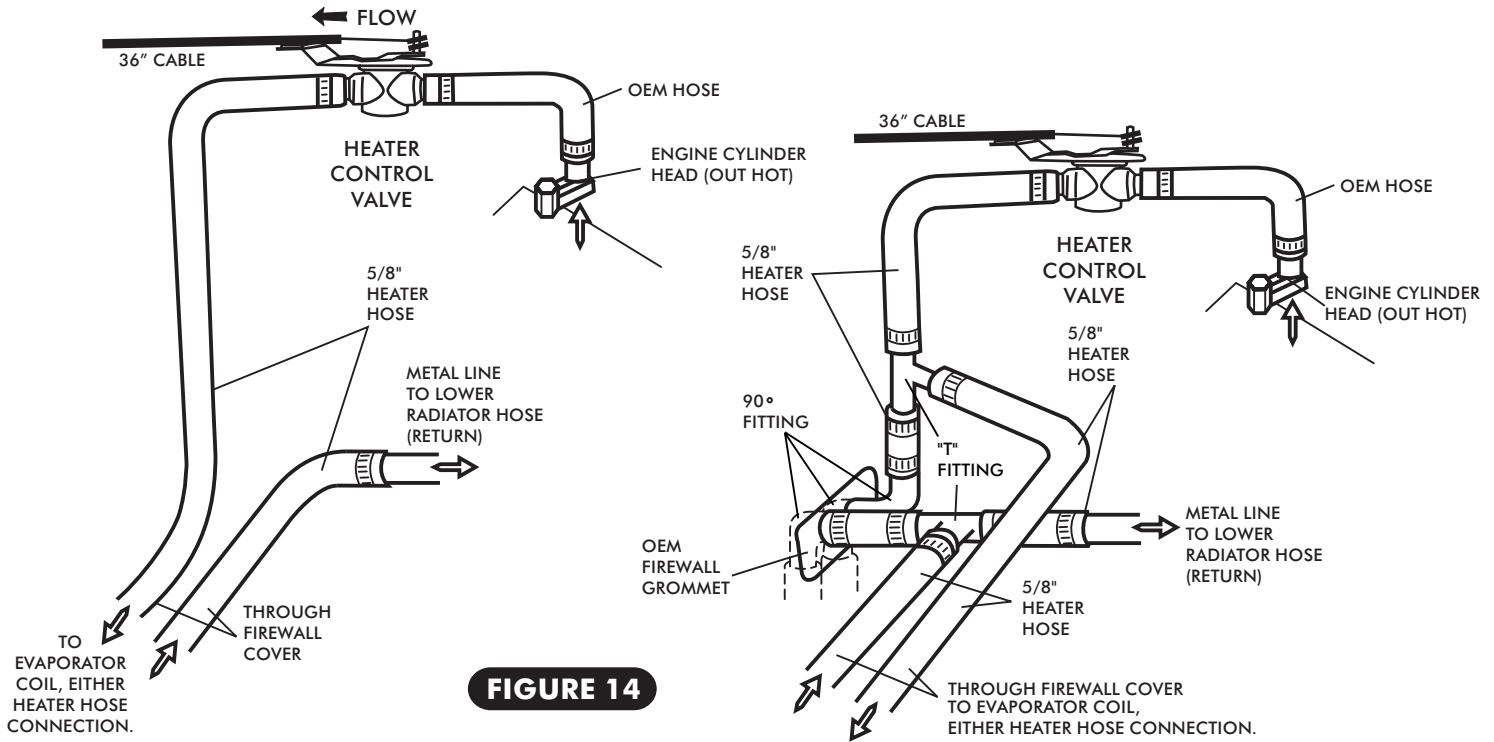

FIGURE 14

IMPORTANT NOTICE:
BLEED AIR FROM THE HEATER AT THE HIGHEST POINT.
HOT - BE VERY CAREFUL.

**WITHOUT OPTIONAL
OEM REAR HEATER**

**WITH OPTIONAL OEM
REAR SEAT HEATER**

DRIVER'S SIDE VENT

- LOCATE BAG CONTAINING DRIVER SIDE VENT ASSEMBLY.
- THE MOUNTING BRACKET WITH THE WIDE SPACED MOUNTING HOLES IS FOR TRUCKS WITH A COLLAPSIBLE STEERING COLUMN. THE BRACKET WITH THE CLOSER SPACED HOLES ARE FOR A SOLID (EARLY) STEERING COLUMN.
- USE THE BRACKET THAT FITS YOUR VEHICLE AND DISCARD THE OTHER.
- MOUNT THE BRACKET TO THE COLUMN USING THE ORIGINAL STEERING COLUMN MOUNTING HARDWARE. SEE FIGURE 15.
- ATTACH THE DRIVER SIDE 2-1/2" X 32" DUCT HOSE INSIDE THE VENT ASSEMBLY.
- USE THE FOUR (4) #6 BLACK METAL SCREWS TO SECURE THE VENT ASSEMBLY TO THE MOUNTING BRACKET. SEE FIGURE 15.

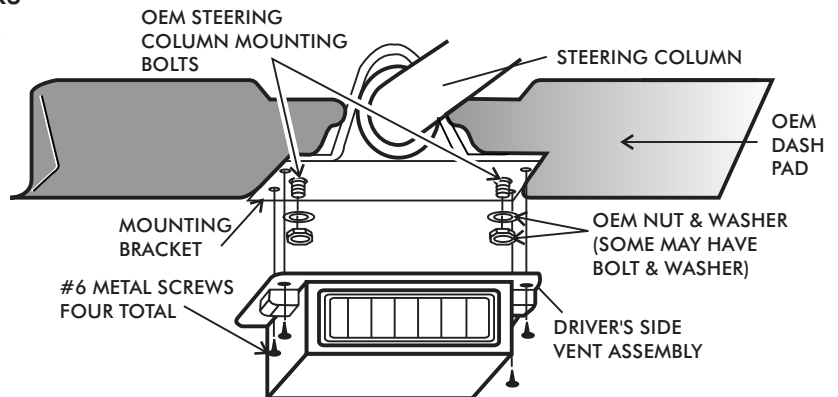
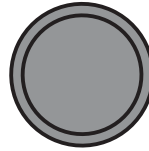

FIGURE 15



OPERATION CONTROLS

- HEATER CONTROL CABLE (SUPPLIED)
PULL: TO OPEN HEATER CONTROL VALVE
PUSH: TO CLOSE HEATER CONTROL VALVE



HEATER CONTROL CABLE

- "FRESH PULL" KNOB (OEM)
PULL: A/C
PUSH: HEATER



A/C-HEATER SWITCH

- DEFROST KNOB (SUPPLIED)
PULL: DEFROST
PUSH: FLOOR OUTLET

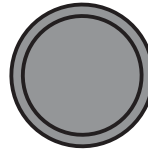

DEFROST/FLOOR OUTLET SWITCH

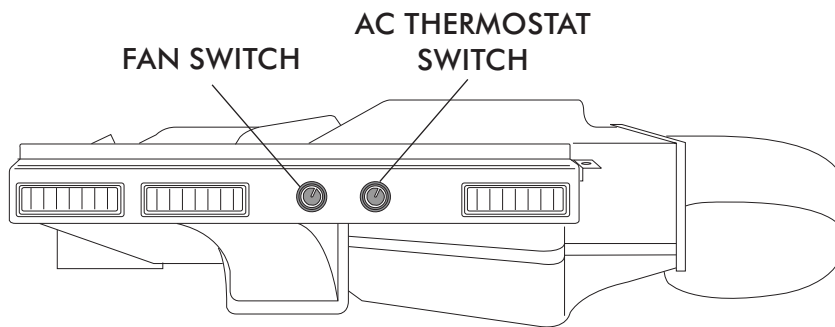

FIGURE 16

FINAL STEPS

- REINSTALL ALL PREVIOUSLY REMOVED ITEMS (BATTERY, RADIATOR, & GRILLE, ETC.).
- FILL RADIATOR WITH 50/50 ANTIFREEZE. IT'S THE OWNERS RESPONSIBILITY TO KEEP FREEZE PROTECTION AT THE PROPER LEVEL FOR THE CLIMATE IN WHICH THE VEHICLE IS OPERATED. FAILURE TO FOLLOW ANTIFREEZE RECOMMENDATIONS WILL CAUSE HEATER CORE TO CORRODE PREMATURELY AND POSSIBLY BURST IN AC MODE AND OR FREEZING WEATHER VOIDING YOUR WARRANTY.
- CHECK COMPLETE A/C ASSEMBLY FOR PROPER OPERATION.
- VINTAGE AIR RECOMMENDS THAT ALL A/C SYSTEMS BE SERVICED BY A CERTIFIED AUTOMOTIVE AIR CONDITIONING TECHNICIAN ONLY. SEE INSIDE COVER FOR SERVICE INFO.



WIRING DIAGRAM

- THE NEW SWITCH CAN REPLACE THE OEM FAN SWITCH IF IT'S NOT USED TO CONTROL A REAR HEATER.
- NO WIRING CHANGE WITH OEM REAR HEATER.

IMPORTANT NOTICE:
 IDENTIFY YOUR BLOWER MOTOR BEFORE WIRING
 TYPE 1 MOTOR OR TYPE 2 MOTOR

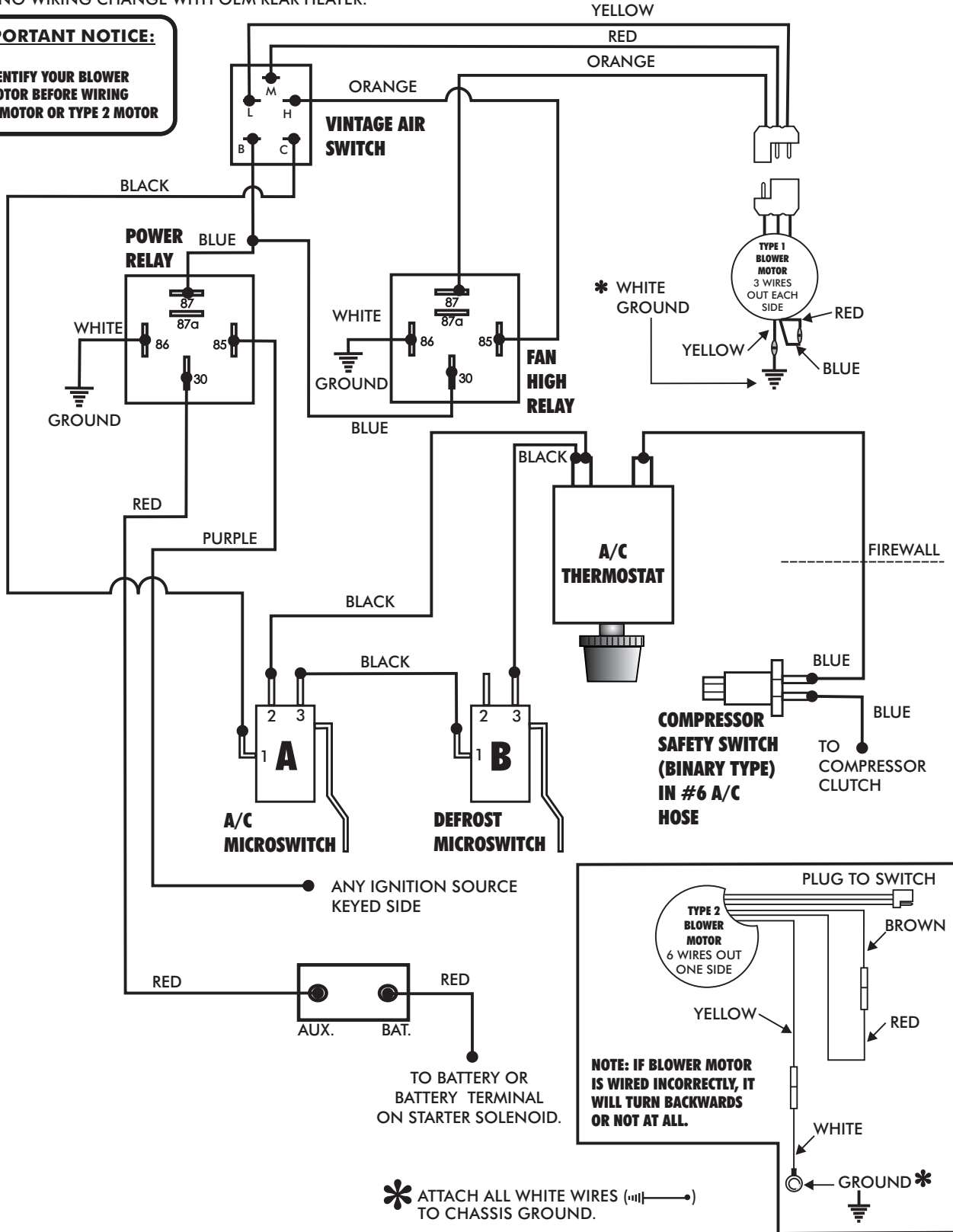

* ATTACH ALL WHITE WIRES () TO CHASSIS GROUND.

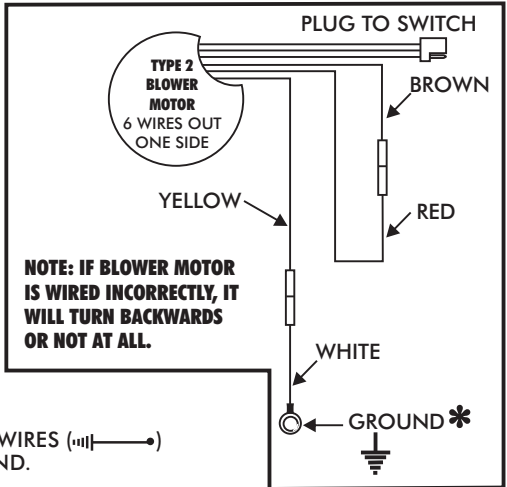

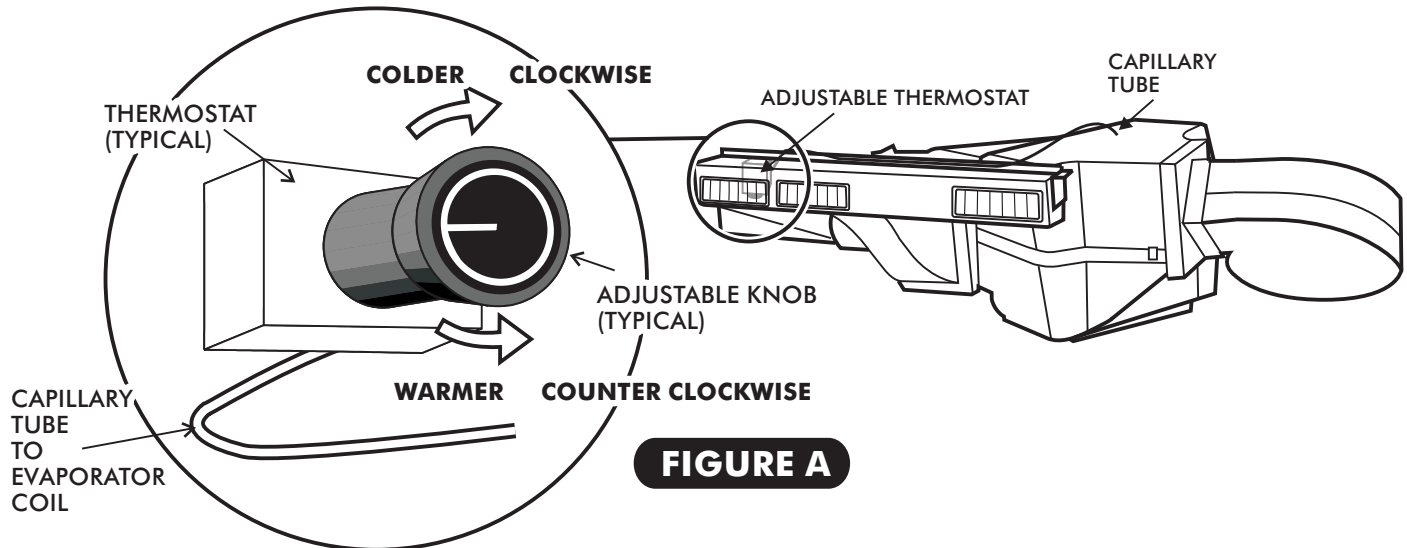

FIGURE A

AIR CONDITIONING ADJUSTMENTS:

- THE AIR CONDITIONER THERMOSTAT CONTROLS COIL TEMPERATURE, IT IS SHIPPED ADJUSTED FULLY COLD (CLOCKWISE), IN THE MAJORITY OF CASES THE A/C WILL OPERATE CORRECTLY AS SHIPPED.
- TURNING THE KNOB ON THE THERMOSTAT TO THE RIGHT (CLOCKWISE) MAKES THE SYSTEM OPERATE COLDER. IF THE THERMOSTAT IS SET TOO COLD THE EVAPORATOR WILL "ICE UP" - THE EVAPORATOR COIL IS RESTRICTED WITH ICE AND COLD AIR FLOW WILL BE REDUCED.
- TURNING THE KNOB TO THE LEFT (COUNTER CLOCKWISE) MAKES THE SYSTEM OPERATE WARMER. THE COMPRESSOR CLUTCH WILL CYCLE OFF FREQUENTLY AND THE A/C SYSTEM WILL NOT GET AS COOL AS IT COULD.

ADJUSTING A/C THERMOSTAT

1.) SYMPTOM: THE A/C WORKS WELL AT FIRST THEN QUILTS COOLING. THE AIR FLOW FROM THE VENTS IS LOW AND THE COMPRESSOR CYCLES INFREQUENTLY.

SOLUTION: THE THERMOSTAT IS SET TOO COLD AND THE EVAPORATOR IS "ICING UP" AND RESTRICTING AIR FLOW. ALLOW THE ICE TO MELT AND SET THE THERMOSTAT WARMER (COUNTER CLOCKWISE) 10% OF A TURN EACH ADJUSTMENT UNTIL THE SYMPTOMS DIMINISH.

2.) SYMPTOM: A/C NEVER GETS COLD AND THE COMPRESSOR CLUTCH CYCLES FREQUENTLY.

SOLUTION: THE THERMOSTAT IS SET TOO WARM. SET THE THERMOSTAT COLDER (CLOCKWISE) 10% OF A TURN EACH ADJUSTMENT UNTIL THE COMPRESSOR CLUTCH CYCLES INFREQUENTLY. AVOID SETTING THE THERMOSTAT TOO COLD.

3.) SYMPTOM: THE A/C NEVER GETS COLD, SOMETIMES EVEN BLOWS HOT, AND THE A/C COMPRESSOR CLUTCH INFREQUENTLY CYCLES OFF.

SOLUTION: THE HEATER MAY BE ON AT ALL TIMES. CAREFULLY FEEL AROUND THE HEATER HOSES AT THE FIREWALL. IF THE HOSES ARE HOT THEN:

- A) - THE HEATER CONTROL VALVE MAY BE INSTALLED BACKWARDS. CHECK THE FLOW DIRECTION ARROW ON THE VALVE AGAINST THE ILLUSTRATION IN YOUR INSTALLATION INSTRUCTIONS.
- B) - IF CABLE OPERATED: THE VALVE MAY BE MISADJUSTED.
- C) - IF VACUUM OPERATED: IT MAY BE GETTING VACUUM AT ALL TIMES (CHECK ELECTRIC SOLENOID).



1968-83 TOYOTA LANDCRUISER FJ40

EVAPORATOR KIT PACKING LIST

EVAPORATOR KIT 75080-LTZ-A

No.	QTY.	PART No.	DESCRIPTION
1.	1	55380-LTE-A	1968-83 TOYOTA LANDCRUISER EVAP. SUBCASE
2.	1	795080	1968-83 TOYOTA LANDCRUISER ACC. KIT

CHECKED BY: _____
 PACKED BY: _____
 DATE: _____

①

**1974-80 TOYOTA
LANDCRUISER
EVAP. SUB CASE
55380-LTE-A**

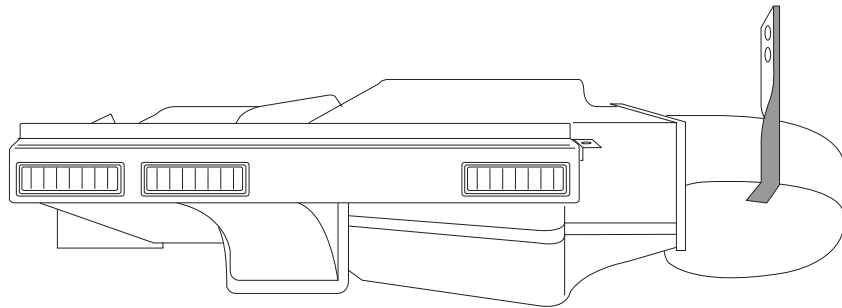

②

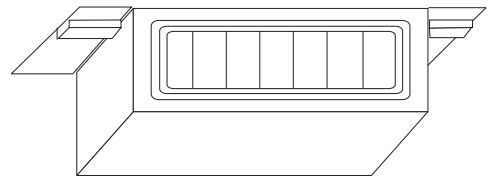
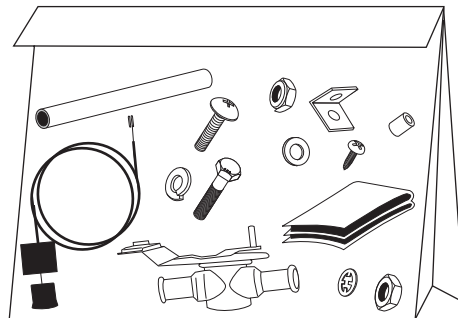
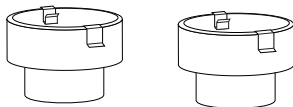
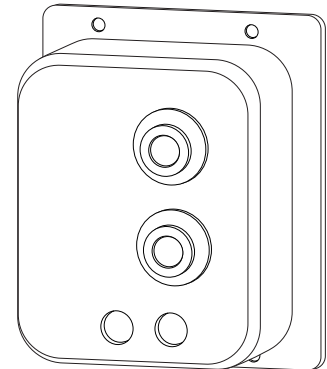
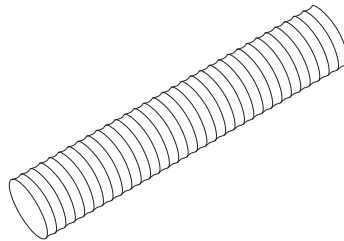
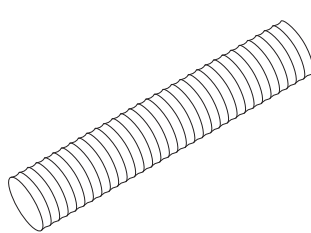

**ACCESSORY KIT
795080**

**NOTE: IMAGES MAY NOT DEPICT ACTUAL PARTS AND QUANTITIES.
REFER TO PACKING LIST FOR ACTUAL PARTS AND QUANTITIES**