

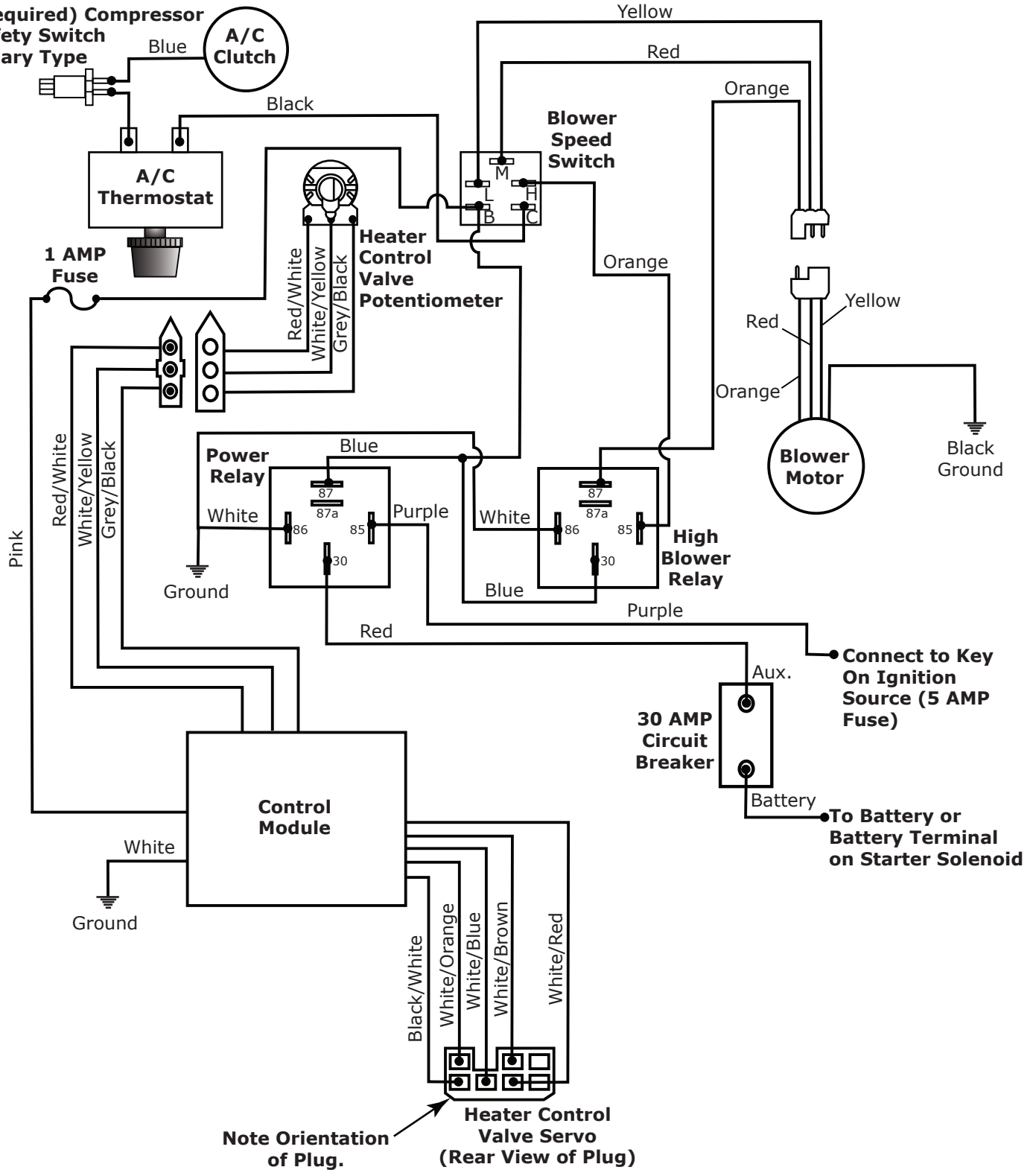

(Required) Compressor Safety Switch Binary Type





www.vintageair.com

Operation of Controls

The Heritage Heat/Cool system employs a combination heat/cool heat exchanger where the evaporator circuit and heater circuit are combined into one unit, with the entering air first passing through the evaporator and then through the heater. This configuration allows the user to cool and dehumidify the cabin air, and then reheat it to a temperature that is comfortable.

For maximum performance and comfort, Vintage Air recommends always running the evaporator as cold as possible by positioning the "C" knob (far right) with the arrow pointing straight up. Then, reheat the air to the desired temperature by blending in heat using the "H" knob (center). For maximum cooling, position all (3) knobs with the arrow pointing straight up.

During the winter months, it can still be helpful to run the A/C compressor to dehumidify the cabin and reduce the potential for window fogging. In this instance, it is still possible to run the thermostat with the arrow pointing straight up, or it can be backed off as desired. For maximum heating, position the "C" knob to its full counterclockwise position (compressor off), and the "H" knob to its full clockwise position (heater control valve fully open).

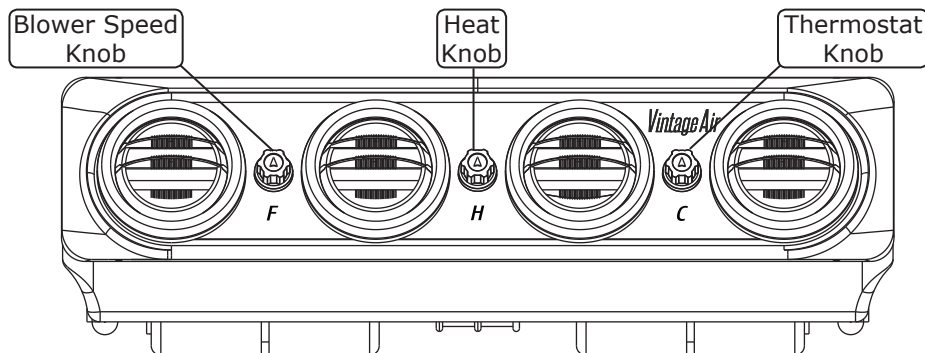

A/C Thermostat Explained

The right knob on the Heritage system controls a mechanical A/C thermostat. This thermostat operates differently than that of a home air conditioning thermostat. An automotive thermostat controls the temperature of the evaporator coil rather than the temperature of the air. Its main purpose is to prevent ice from forming between the fins of the coil, as ice blocks airflow and limits A/C performance. The thermostat employs a gas-filled "capillary tube" probe, which is inserted into the coldest part of the coil, and will cycle the compressor on and off in response to the temperature sensed by the probe. By adjusting the "C" knob to a position with the arrow pointing straight up, the thermostat will turn the compressor off at approximately 34°F at the sensing location. As a result, no ice will be allowed to form on the coil. Sometimes, in areas of very low humidity, it is possible to adjust the thermostat colder without ice forming. Adjusting the thermostat to a full clockwise position will turn off the compressor at approximately 28°F. If symptoms of evaporator icing develop, such as reduced airflow with elevated vent temperature, reduce the thermostat setting by rotating the "C" knob counterclockwise. This will allow the evaporator to thaw.



www.vintageair.com

Packing List:
Heritage Series, Heat/Cool, Pearl
(674011)

No.	Qty.	Part No.	Description
1.	1	746003	Heritage Under Dash Sub Case, Heat/Cool, Pearl
2.	1	191045	Hardware Kit
3.	1	633001	Drain Kit

Checked By: _____
 Packed By: _____
 Date: _____

Packing List:
Heritage Series, Heat/Cool, Turned (674012)

No.	Qty.	Part No.	Description
1.	1	746004	Heritage Under Dash Sub Case, Heat/Cool, Turned
2.	1	191045	Hardware Kit
3.	1	633001	Drain Kit

Checked By: _____
 Packed By: _____
 Date: _____

Packing List:
Heritage Series, Heat/Cool, Brushed (674013)

No.	Qty.	Part No.	Description
1.	1	746005	Heritage Under Dash Sub Case, Heat/Cool, Brushed
2.	1	191045	Hardware Kit
3.	1	633001	Drain Kit

Checked By: _____
 Packed By: _____
 Date: _____

Packing List:
Heritage Series, Heat/Cool, Black Turned (674014)

No.	Qty.	Part No.	Description
1.	1	746007	Heritage Under Dash Sub Case, Heat/Cool, Black Turned
2.	1	191045	Hardware Kit
3.	1	633001	Drain Kit

Checked By: _____
 Packed By: _____
 Date: _____

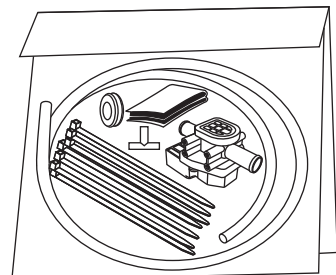
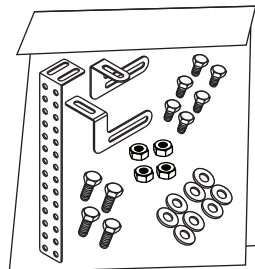
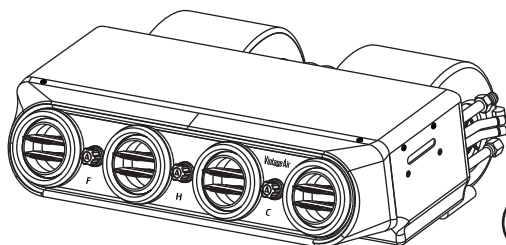

NOTE: Images may not depict actual parts and quantities.
Refer to packing list for actual parts and quantities.