



an ISO 9001: 2015 Registered Company

STREAMLINE

4 KNOB PANEL ANODIZED

491229

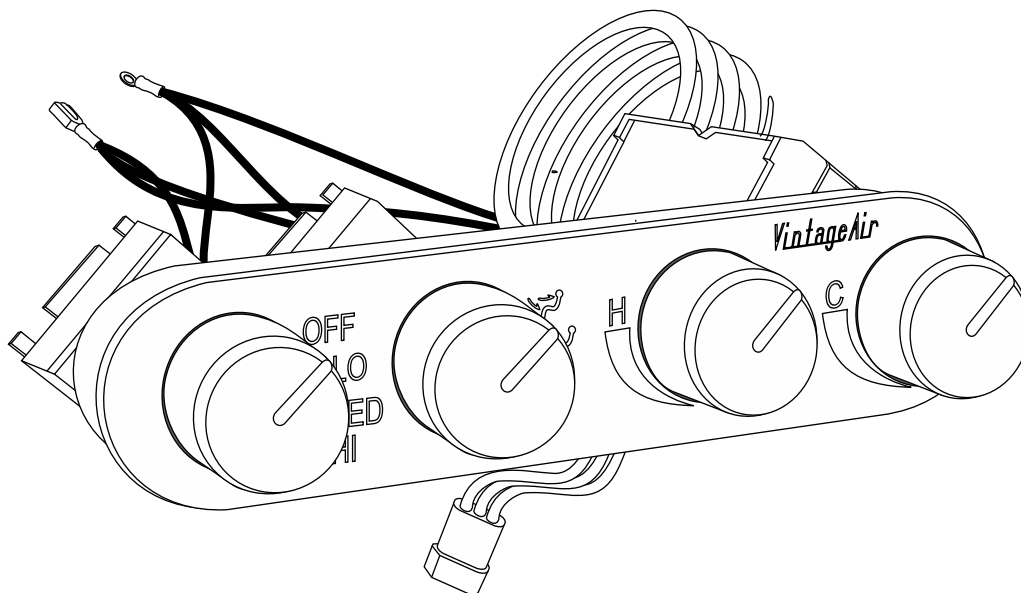

18865 Goll St. San Antonio, TX 78266

Phone: 800-862-6658

Sales: sales@vintageair.com

Tech Support: tech@vintageair.com

www.vintageair.com



TABLE OF CONTENTS

PAGES

1. COVER
2. TABLE OF CONTENTS
3. PACKING LIST
4. CONTROL PANEL TEMPLATE & INSTALLATION
5. INSTALLATION DIAGRAM
6. OPERATION OF CONTROLS
7. GEN II COMPAC & SUPER WIRING DIAGRAM
8. GEN II MINI WIRING DIAGRAM
9. THERMOSTAT ADJUSTMENT PAGE
10. PARTS BREAK DOWN OF CONTROL PANEL KIT
11. CONTROL PANEL KIT PACKING LIST



CONTROL PANEL PACKING LIST

CONTROL PANEL
491229

No.	QTY.	PART No.	DESCRIPTION
1.	1	491229	STRMLINE 4 KNOB CONTROL PANEL (ANDZ)

**** BEFORE BEGINNING INSTALLATION OPEN ALL PACKAGES AND CHECK CONTENTS OF SHIPMENT. PLEASE REPORT ANY SHORTAGES DIRECTLY TO VINTAGE AIR WITHIN 15 DAYS. AFTER 15 DAYS, VINTAGE AIR WILL NOT BE RESPONSIBLE FOR MISSING OR DAMAGED ITEMS.**

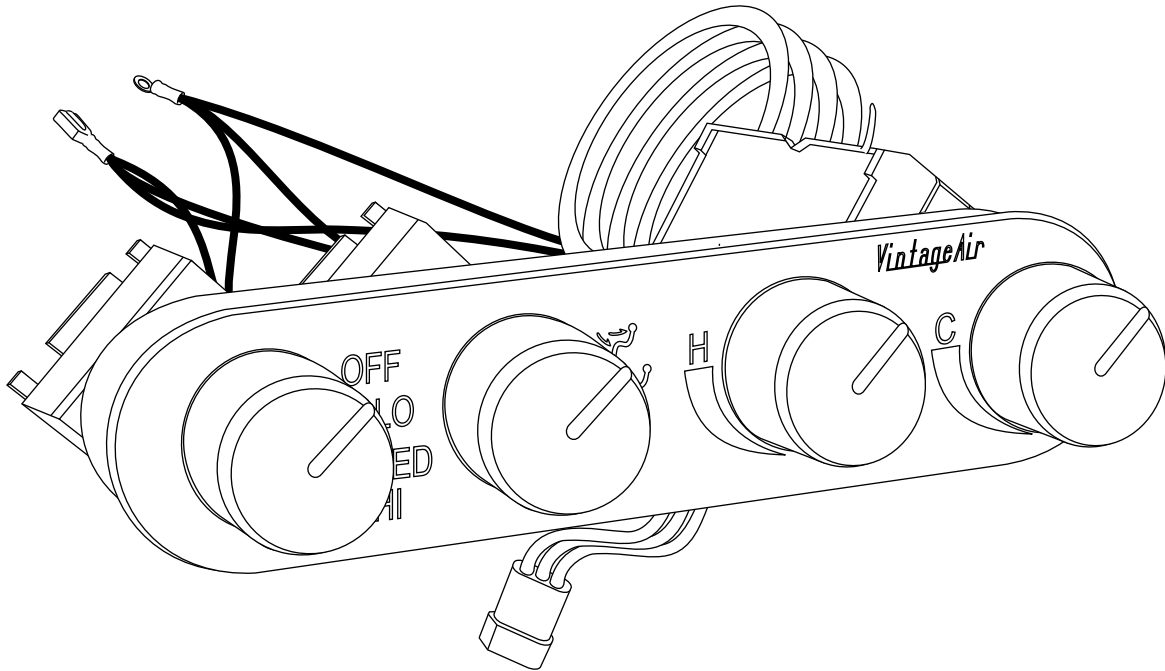



STREAMLINE 4 KNOB CONTROL PANEL TEMPLATE

TEMPLATE FOR 491200-RUA AND 491229

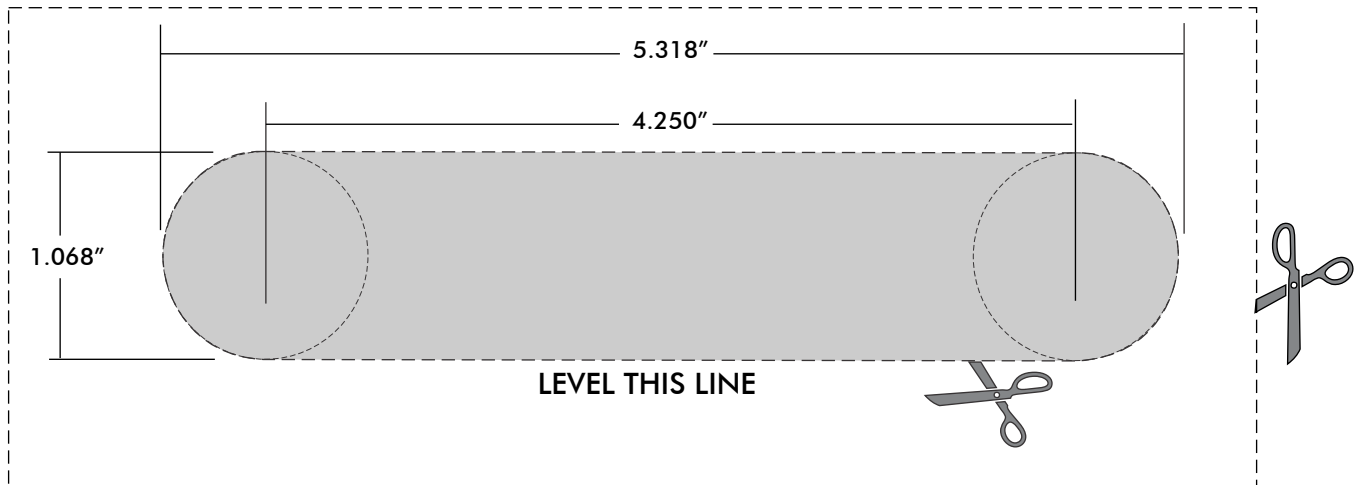

CONTROL PANEL INSTALLATION

- SELECT A SUITABLE LOCATION FOR THE CONTROL PANEL. CONSIDER HEATER CONTROL VALVE LOCATION, WIRING HARNESS LENGTH AND CAPILLARY TUBE TO EVAPORATOR DISTANCE.
- AFTER SELECTING A LOCATION FOR THE PANEL, MASK THE AREA 2 ½" (TALL) x 6 ½" (WIDE).
- CUT OUT TEMPLATE ABOVE AND CUT OUT THE GREY SECTION OF TEMPLATE ALONG DOTTED LINE.
- BE SURE TO LEVEL TEMPLATE ON DASH.
- MARK DASH WITH MARKER OR SCRIBE.
- CUT OUT OPENING FOR PANEL.
- REMOVE (3) CONTROL PANEL BRACKET MOUNTING SCREWS AND REMOVE THE CONTROL PANEL BRACKET WITH SWITCHES FROM CONTROL PANEL FACE. SEE FIGURE 1, PAGE 5
- INSTALL FACE IN DASH AND REINSTALL CONTROL PANEL BRACKET WITH SWITCHES. SEE FIGURE 2 & 2a, PAGE 5
- CONNECT THE SET OF WIRES COMING FROM THE LIGHT BULBS WITH THE RING TERMINAL TO GROUND.
- CONNECT THE OTHER SET OF WIRES COMING FROM THE LIGHT BULBS WITH THE FEMALE INSULATED TERMINAL INTO THE VEHICLES HARNESS THAT POWERS YOUR INSTRUMENT PANEL LIGHTS (+12 VOLT).
- WIRE THE SYSTEM AS SHOWN ON PAGE 7 FOR GEN II COMPAC & SUPER UNITS OR PAGE 8 FOR GEN II MINI UNITS.
- INSERT CAPILLARY TUBE THRU THE STICKER ON TOP OF THE EVAPORATOR THE ENTIRE THICKNESS OF THE COIL. SEE PAGE 9.



CONNECTS TO
EXISTING INSTRUMENT
PANEL LIGHT
WIRING (+)

CONNECT TO
CHASSIS GROUND

CONTROL PANEL
BRACKET w/ SWITCHES

CONTROL PANEL
FACE

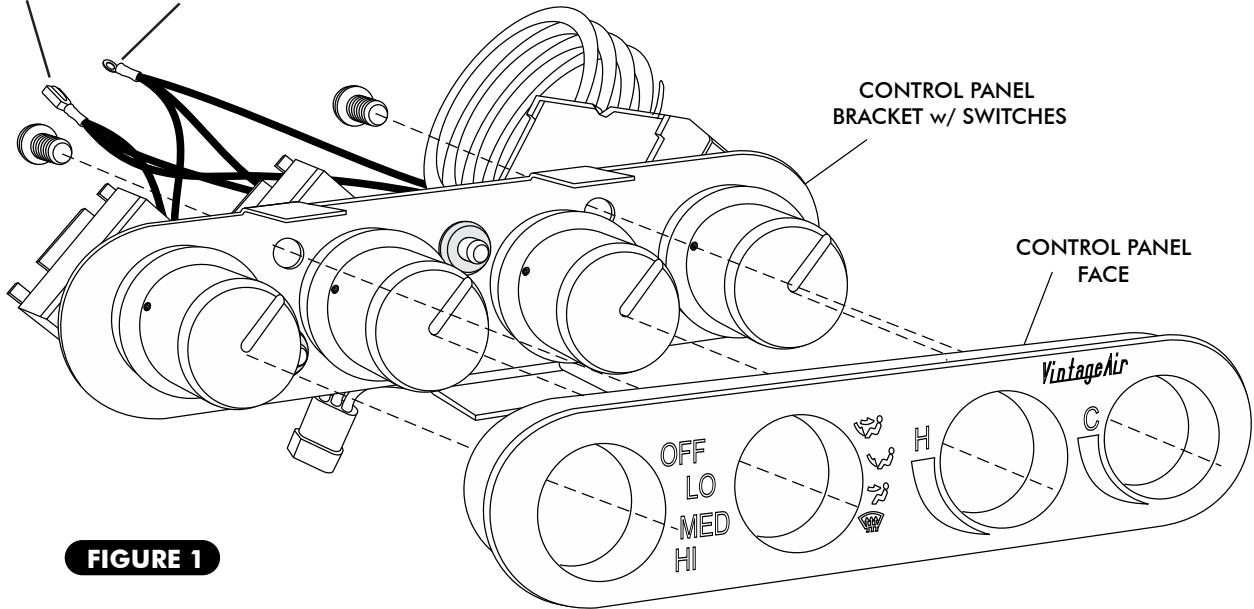
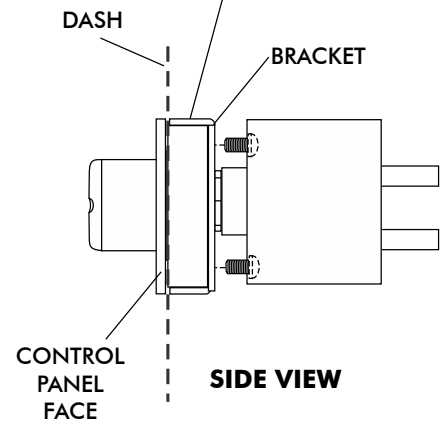
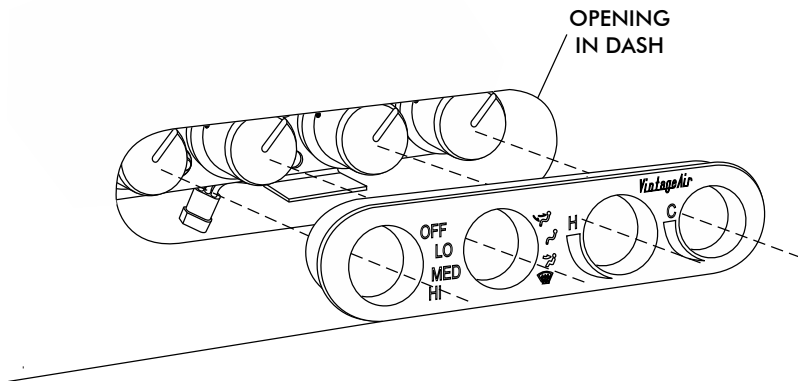

FIGURE 1

**NOTE: TABS MAY NEED
TO BE TRIMMED DEPENDING
ON DASH THICKNESS**





491200-RUA AND 491229

STREAMLINE 4 KNOB

CONTROL PANEL OPERATION

FAN SPEED CAN BE OPERATED IN ANY MODE POSITION.

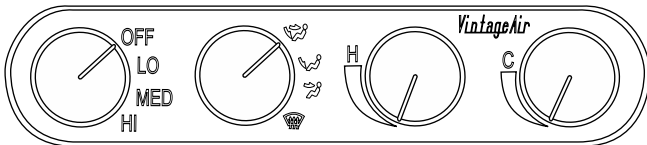

SYSTEM OFF

TURNING THE FAN SPEED KNOB TO **OFF** WILL SHUT DOWN THE SYSTEM IN ANY MODE.

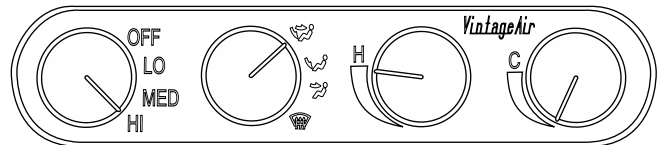

VENT HEAT MODE

SELECT FAN SPEED. SET MODE SWITCH TO DASH, AND TURN THE HEAT KNOB TO THE RIGHT FOR HEAT MODE. **HOT**

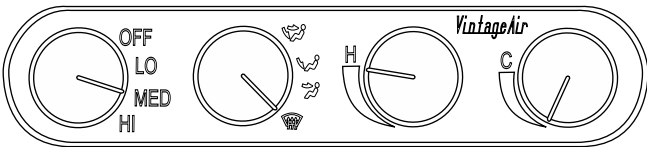

DEFROST MODE

(OPTIONAL, FOR DEFROST ONLY!)

SELECT FAN SPEED. SET MODE SWITCH TO DEFROST. TURN THE COLD AIR KNOB SLIGHTLY TO THE RIGHT, TO ENGAGE THE COMPRESSOR. TURN KNOB TO THE RIGHT TO OPEN HOT WATER VALVE TO PROVIDE HEATED DEFROST AIR.

DEHUMIDIFIED DEFROST WILL BE DIRECTED TO THE WINDSHIELD.

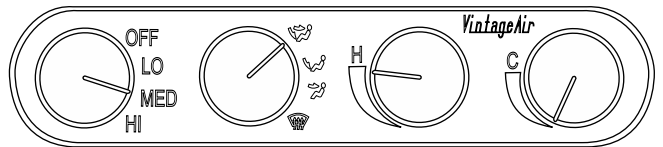

BI-LEVEL HEAT MODE

SELECT FAN SPEED. SET MODE SWITCH TO BI, FOR BI LEVEL, AND TURN THE HEAT KNOB TO THE RIGHT FOR HEAT. **HOT AIR WILL EXIT THE DASH VENTS & FLOOR.**

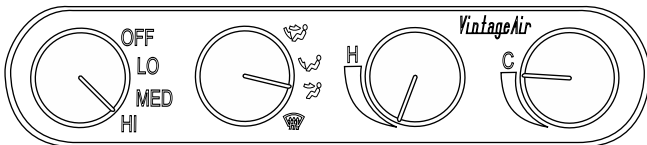

A/C MODE

TURN COLD AIR KNOB TO THE RIGHT FOR COLD AIR, AND ADJUST MODE LEVER TO VENT OR BI-LEVEL. **COLD AIR WILL FLOW OUT VENTS.** **NOTE:** DUCT TEMPERATURE CAN BE RAISED BY **SLIGHTLY TURNING** HEAT KNOB TO THE RIGHT TO OPEN HOT WATER VALVE. HOT WATER VALVE MUST BE CLOSED (FULL

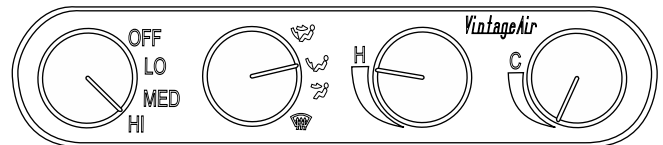

FLOOR HEAT MODE

SELECT FAN SPEED. SET MODE LEVER TO FLOOR, AND TURN THE HEAT KNOB TO THE RIGHT FOR HEAT MODE. **HOT AIR WILL EXIT THE FLOOR VENTS.**



WIRING DIAGRAM - GEN II MINI UNITS
 HEAT/COOL/DEFROST 491200-RUA & 491229 STREAMLINE 4 KNOB
 CONTROL PANEL

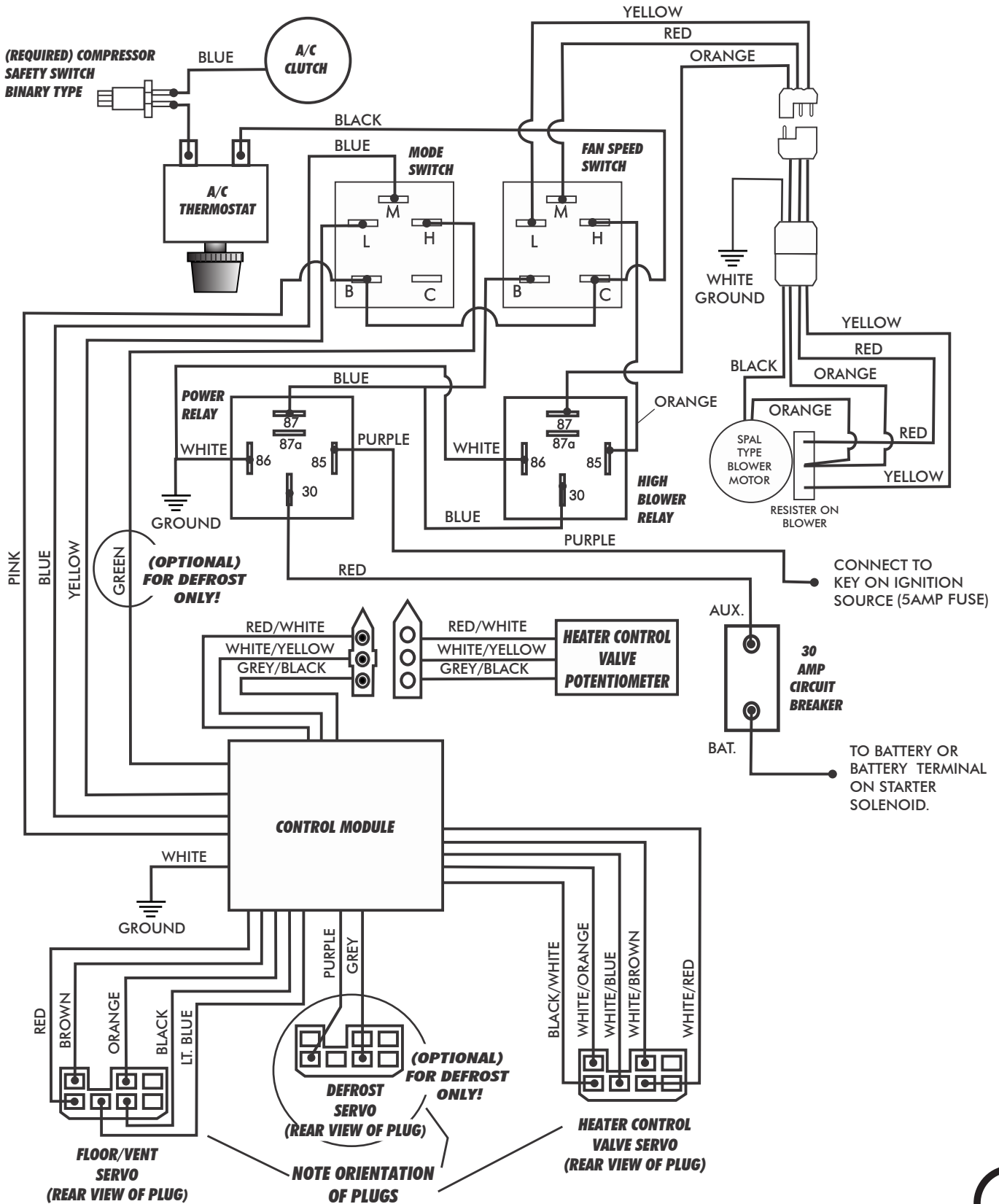

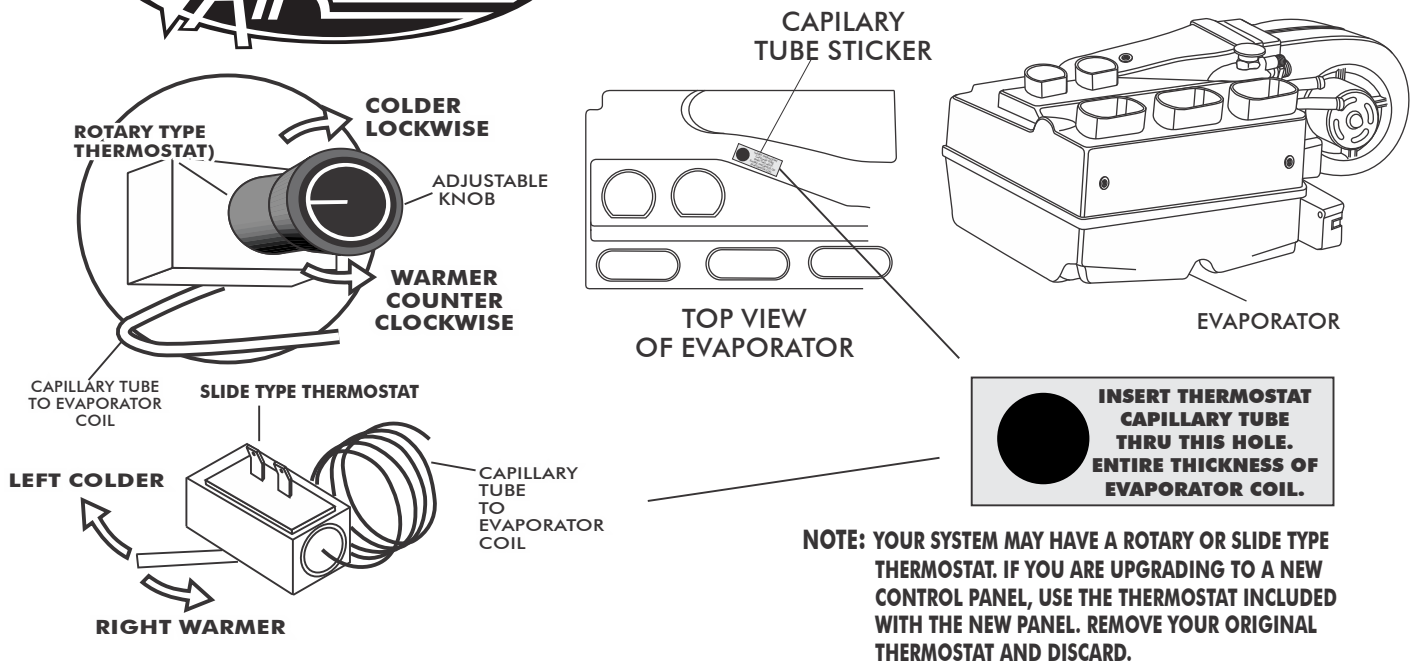

**INSERT THERMOSTAT
CAPILLARY TUBE
THRU THIS HOLE.
ENTIRE THICKNESS OF
EVAPORATOR COIL.**

NOTE: YOUR SYSTEM MAY HAVE A ROTARY OR SLIDE TYPE THERMOSTAT. IF YOU ARE UPGRADING TO A NEW CONTROL PANEL, USE THE THERMOSTAT INCLUDED WITH THE NEW PANEL. REMOVE YOUR ORIGINAL THERMOSTAT AND DISCARD.

AIR CONDITIONING ADJUSTMENTS:

- ï THE AIR CONDITIONER THERMOSTAT CONTROLS COIL TEMPERATURE. ROTARY TYPE THERMOSTATS ARE SHIPPED ADJUSTED FULLY COLD (CLOCKWISE), IN THE MAJORITY OF CASES THE A/C WILL OPERATE CORRECTLY AS SHIPPED.
- ï TURNING THE KNOB ON THE **ROTARY TYPE THERMOSTAT** TO THE RIGHT (CLOCKWISE) MAKES THE SYSTEM OPERATE COLDER. MOVING THE LEVER TOWARD **COLDER** ON THE **SLIDE TYPE THERMOSTAT** MAKES THE SYSTEM OPERATE COLDER. IF THE THERMOSTAT IS SET TOO COLD THE EVAPORATOR COIL WILL "ICE UP"- MEANING, THE EVAPORATOR COIL IS RESTRICTED WITH ICE AND COLD AIR FLOW WILL BE REDUCED.
- ï TURNING THE KNOB TO THE LEFT (COUNTER CLOCKWISE) ON A **ROTARY TYPE THERMOSTAT** MAKES THE SYSTEM OPERATE WARMER. MOVING THE LEVER TOWARD THE RED LINES ON A **SLIDE TYPE THERMOSTAT** MAKES THE SYSTEM OPERATE WARMER. THE COMPRESSOR CLUTCH WILL CYCLE OFF FREQUENTLY. THE EVAPORATOR COIL WILL NOT GET AS COLD AND THE AIR TEMPERATURE WILL NOT BE AS COLD.

ADJUSTING A/C THERMOSTAT

- 1.) **SYMPTOM:** THE A/C WORKS WELL AT FIRST THEN QUILTS COOLING. THE AIR FLOW FROM THE VENTS IS LOW, AND THE COMPRESSOR CLUTCH CYCLES INFREQUENTLY.
SOLUTION: THE THERMOSTAT IS SET TOO COLD AND THE EVAPORATOR IS "ICING UP" AND RESTRICTING AIR FLOW. **ALLOW THE ICE TO MELT** AND SET THE **ROTARY TYPE THERMOSTAT** WARMER (COUNTER CLOCKWISE) 1/8 OF A TURN EACH ADJUSTMENT UNTIL THE SYMPTOMS DIMINISH. ADJUST THE **SLIDE TYPE THERMOSTAT** IN 1/8" INCREMENTS TOWARD THE SMALLER BLUE GRADIENTS, UNTIL THE SYMPTOMS DIMINISH.
- 2.) **SYMPTOM:** A/C NEVER GETS COLD AND THE COMPRESSOR CLUTCH CYCLES FREQUENTLY.
SOLUTION: THE THERMOSTAT IS SET TOO WARM. SET THE **ROTARY TYPE THERMOSTAT** COLDER (CLOCKWISE) 1/8 OF A TURN EACH ADJUSTMENT, UNTIL THE DESIRED AIR TEMPERATURE IS REACHED. ADJUST **SLIDE TYPE THERMOSTAT** IN 1/8" INCREMENTS TOWARD COLDER UNTIL THE DESIRED AIR TEMP IS REACHED **AVOID SETTING THE THERMOSTAT TOO COLD.**
- 3.) **SYMPTOM:** THE A/C NEVER GETS COLD, SOMETIMES EVEN BLOWS HOT, AND THE A/C COMPRESSOR CLUTCH INFREQUENTLY CYCLES OFF.
SOLUTION: THE HEATER MAY BE ON AT ALL TIMES. **CAREFULLY** FEEL THE HEATER HOSE BETWEEN THE **EVAPORATOR** AND THE **HEATER CONTROL VALVE**. THIS HOSE SHOULD NOT BE HOT IN THE **A/C MODE**. IF THE HOSES ARE HOT
 - A)- THE HEATER CONTROL VALVE MAY BE INSTALLED BACKWARDS. CHECK THE FLOW DIRECTION ARROW ON THE VALVE AGAINST THE ILLUSTRATION IN YOUR INSTALLATION INSTRUCTIONS.
 - B)- IF CABLE OPERATED: THE VALVE MAY BE MISADJUSTED.
 - C)- IF VACUUM OPERATED: IT MAY BE GETTING VACUUM AT ALL TIMES (CHECK ELECTRIC SOLENOID).
 - D)- THE HEATER CONTROL VALVE MAY BE INSTALLED IN THE WRONG HOSE. IT MUST BE INSTALLED IN THE HOSE COMING FROM THE INTAKE MANIFOLD ENGINE COOLANT **PRESSURE PORT**.



STREAMLINE 4 KNOB CONTROL PANEL (ANDZ) PACKING LIST

No.	QTY.	PART No.	DESCRIPTION
1.	2	23123-VUW	BUDDY CLIP
2.	1	23120-VUW	#10 FEMALE RING TERMINAL
3.	1	23122-VUW	FEMALE INSULATED TERMINAL
4.	1	18425-VUB	7/16" FLAT WASHER
5.	6	18157-VUB	7/16" SHAFT NUT
6.	3	18198-VUB	8-32 x 1/4" PH PAN HEAD SCREW
7.	3	33138-VUI	1/4" RUBBER GROMMET
8.	2	23139-VUW	6" FEMALE JUMPER WIRE
9.	3	20557-VUP	LIGHT BULB
10.	1	11413-RUA	ROTARY POTENTIOMETER with PIG TAIL
11.	1	491228	STREAMLINE 4 KNOB PANEL (BLACK ANODIZED)
12.	3	492016	KNOB ASSEMBLY, STREAMLINE 250 x 156 BLACK ANODIZED
13.	2	11458-VUS	3-SPEED BLOWER SWITCH
14.	1	11092-VUT	48" ADJUSTABLE ROTARY THERMOSTAT
15.	1	647201-PUB	CONTROL PANEL BRACKET
16.	1	492017	KNOB ASSEMBLY, STREAMLINE 6 x 4.5 MM BLACK ANODIZED
17.	2	186890	POTENTIOMETER FLAT WASHER
18.	2	186892	POTENTIOMETER SHAFT NUT

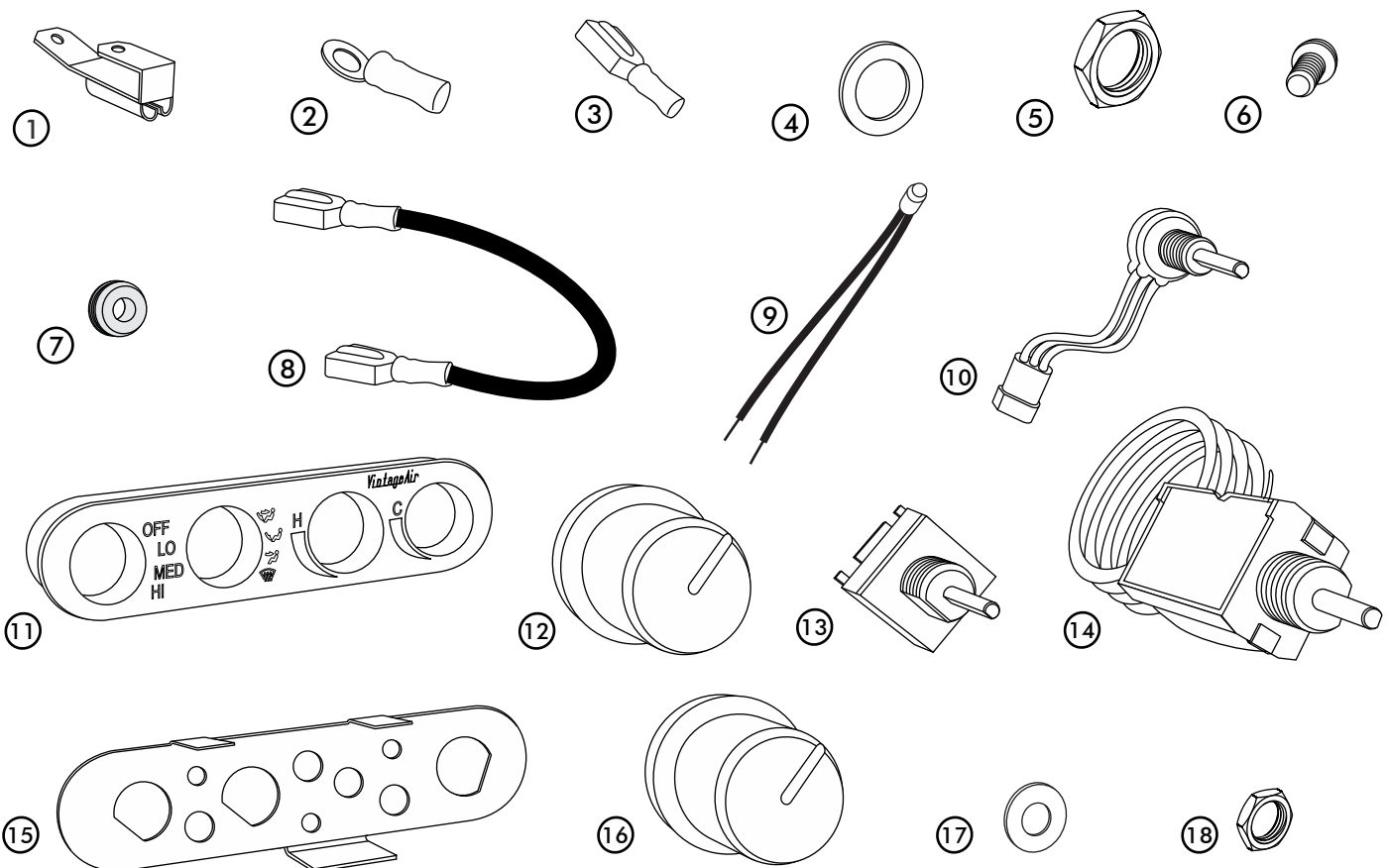



CONTROL PANEL PACKING LIST

CONTROL PANEL
491229

No.	QTY.	PART No.	DESCRIPTION
1.	1	491229	STRMLINE 4 KNOB CONTROL PANEL (ANDZ)

CHECKED BY: _____
PACKED BY: _____
DATE: _____

