



**1987-95 Jeep YJ
16" LoPro 500-Watt Brushless Fan/
Shroud Kit
(372035)**



**18865 Goll St. San Antonio, TX 78266
Phone: 800-862-6658
Sales: sales@vintageair.com
Tech Support: tech@vintageair.com
www.vintageair.com**



www.vintageair.com

Table of Contents

Cover..... 1

Table of Contents..... 2

Packing List/Parts Disclaimer..... 3

Theory of Operation, Special Tools Required, Features..... 4

Fan Dimensions..... 5

Disassembly..... 6

Fan Installation..... 7

Radiator Hose Modification..... 8

Power Harness Installation..... 9

Power Harness Installation (Cont.)..... 10

Operation..... 11

Troubleshooting..... 12

Wiring Schematic..... 13

Packing List..... 14

Important Notice—Please Read

- This kit was developed using the OEM Radiator. If using an aftermarket radiator, modifications to the shroud may be necessary. Before purchasing the fan and shroud assembly, verify shroud and mounting hole dimensions shown on Page 5.
- A trinary switch (11086-VUS) must be used when installing an electric fan in an A/C equipped vehicle.
- This kit requires the purchase of a fan controller rated for the engine thermostat setting. The controller is not included in this kit due to engine swaps or upgraded settings on OEM.
- The OEM thermostast for the 1987-95 Jeep YJ is 195°, therefore the 500 watt 195° controller kit is recommended (Vintage Air Part # 113014).
- Vintage Air also offers 500 watt 165° thermostast controller kit (113016) and 500 watt 180° thermostast controller kit (113015) (As written above).

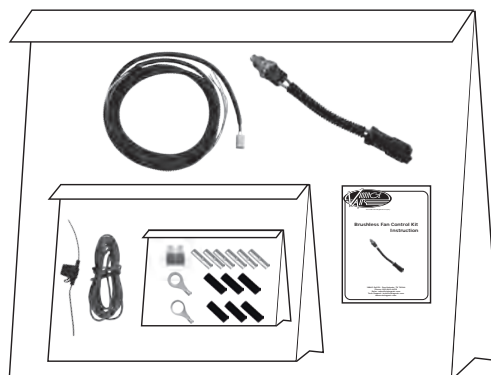

195° Thermostat
500-Watt Brushless Fan
Controller Kit
113014
(NOT INCLUDED)



www.vintageair.com

Packing List: Fan/Shroud Kit (372035)

No.	Qty.	Part No.	Description
1.	1	372034	Brushless Fan Assembly
2.	1	231088	Wiring Kit, Brushless Fan Power 6GA
3.	1	701031	Hose Adapter, 34mm Joint Pipe Radiator

**** Before beginning installation, open all packages and check contents of shipment. Please report any shortages directly to Vintage Air within 15 days. After 15 days, Vintage Air will not be responsible for missing or damaged items.**

1



2

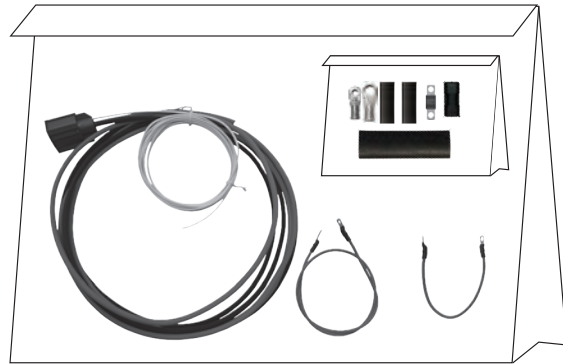

3



NOTE: Images may not depict actual parts and quantities. Refer to packing list for actual parts and quantities.



www.vintageair.com

Theory of Operation

Vintage Air's new Brushless LoPro line of engine cooling fans are based on Spal's latest motor and blade technology, ensuring the absolute highest cooling performance available anywhere. While most competitors' fans use 150-250W motors, Vintage Air brushless fans are available with either 500 or 850W motors and feature model specific mounts and shrouds to ensure an easy, clean and reliable installation.

VA brushless fans have integrated variable speed controllers, which eliminate the need for relays. Variable speed means the fan starts up softly and only runs as hard as is needed to cool the engine, allowing an extremely powerful motor without putting unnecessary burden on the electrical system. The net result is that the fan will be smoother, quieter and more reliable than conventional single speed brushed designs.

Due to the extreme performance potential of these fans and the unique way in which they operate, it is **VERY IMPORTANT** that you thoroughly read and understand the installation and operation instructions prior to installation. Unlike most conventional fans currently on the market, Vintage Air's 500 and 850W brushless fans require unique wiring, control signal and troubleshooting strategies.

All VA brushless fans require an external means of supplying a specific PWM control signal to the fan. These fans will not operate by any other means, i.e. "hotwired," which is also a consideration during troubleshooting.

Special Tools Required:

- High quality crimp tool to crimp 6GA and 18GA butt splices. For the most professional 6GA crimp, Vintage Air recommends MOLEX 19284-0034 Hand Crimp Tool. Vintage Air also stocks a more affordable option suitable for 6GA and 18GA crimps: Vintage Air PN 424009.
- High quality wire strip tool for 6GA and 18GA wires.
- Heat gun for applying heat shrink tubing.
- Digital volt meter for confirming proper grounding and power connections.

Features:

- Designed from the ground up for primary engine and AC cooling duty.
- Maximum cooling power available when you need it, automatically dials back when you don't.
- Extremely long life (up to 40,000hr).
- Waterproof (IP68).
- Easy to install and set-up, stand-alone controllers available.
- May be controlled by several aftermarket engine controllers (positive logic duty cycle definition@50-150Hz).
- Quiet operation (85dBA at 1 m from the fan module - lateral side).
- Laser cut, CNC bent and powder coated steel bracket with mounting hardware designed for specific vehicle applications.
- Model specific ABS shroud gathers and directs air flow across the entire radiator face ensuring maximum cooling performance.



www.vintageair.com

Fan Dimensions

NOTE: Radiators vary in width between manufacturers. Even original radiators may vary due to modifications over the years. This design is based on an original 1987-95 radiator. Verify measurements prior to installation to ensure this kit fits your radiator.

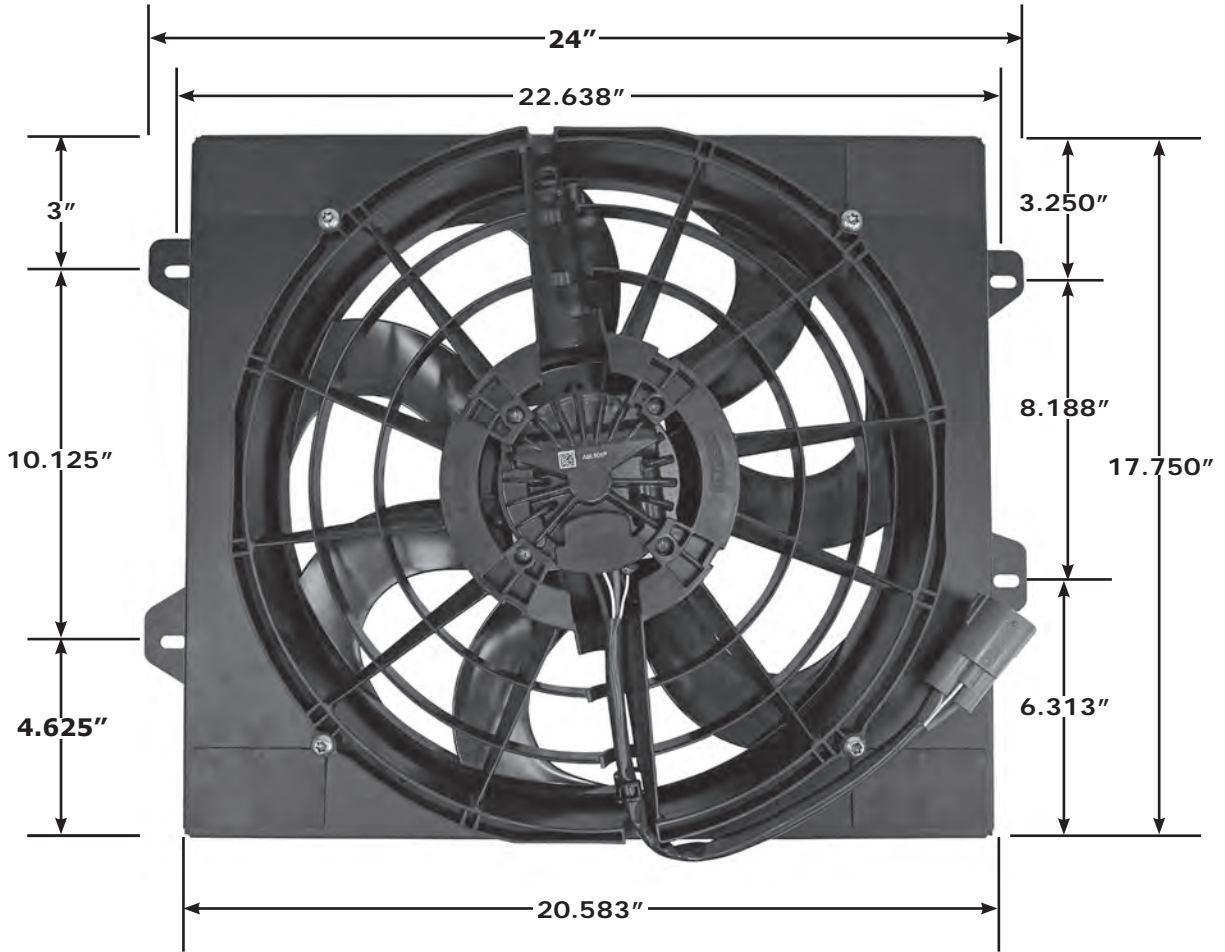



www.vintageair.com

Disassembly

NOTE: Before starting the installation, check the function of the vehicle (horn, lights, etc.) for proper operation, and study the instructions, illustrations, photos & diagrams.

Perform the following:

1. Disconnect the negative terminal of the battery (See Photo 1, below).
2. Drain enough coolant to remove the upper radiator hose.
3. Remove the upper radiator hose (See Photo 2, below).
4. Remove the OEM cooling fan and fan shroud (retain hardware) (See Photo 3, below).

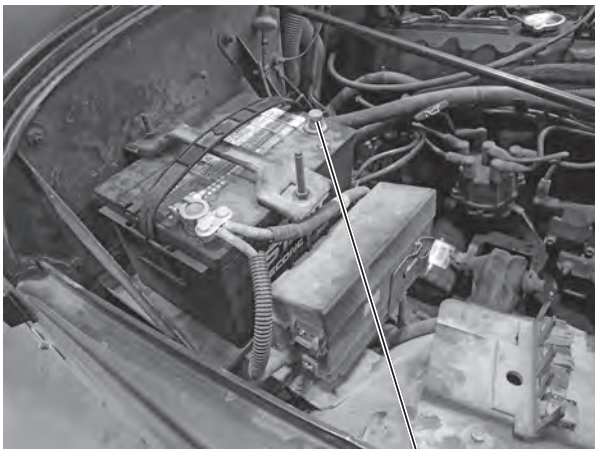

Photo 1

Disconnect negative terminal of battery

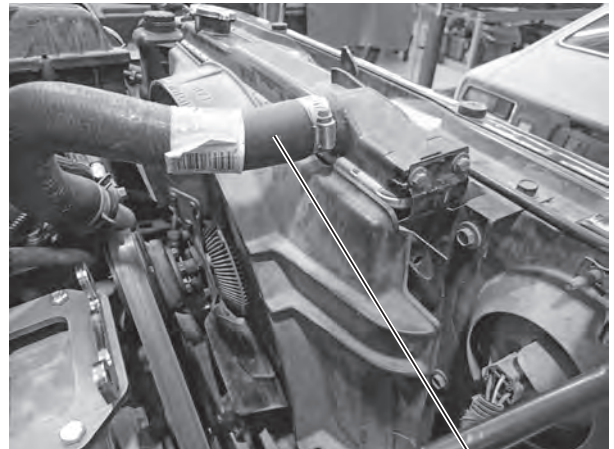

Photo 2

Remove upper radiator hose

Remove OEM cooling fan and fan shroud

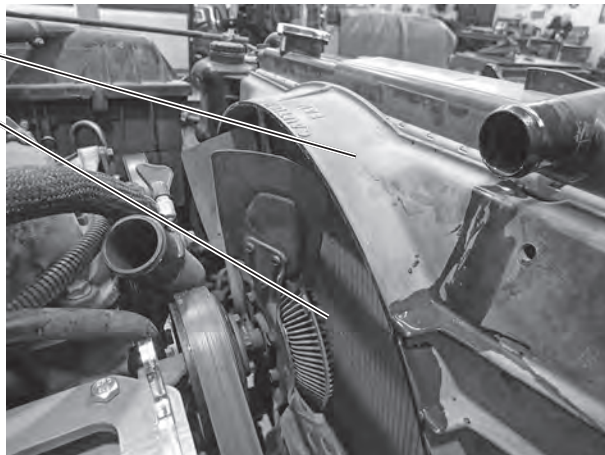

Photo 3



www.vintageair.com

Fan Installation

1. Reinstall the water pump pulley hardware as shown in Photo 1, below.
2. Install the new fan assembly onto the radiator using the OEM fan shroud hardware (See Photo 2, below).
NOTE: The new assembly will be mounted in the OEM fan shroud position.
3. Reinstall the power steering reservoir in the OEM position (See Photo 3, below).

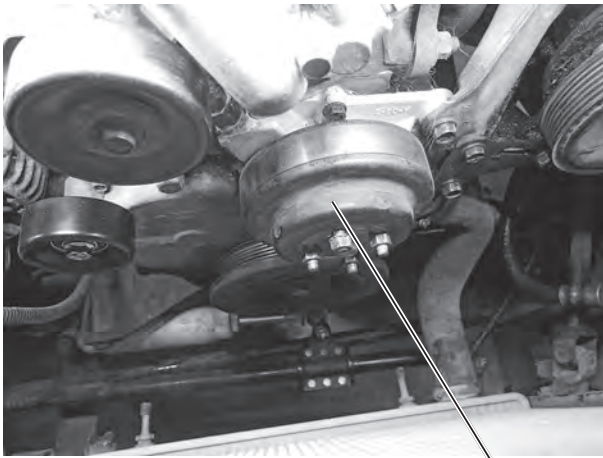

Photo 1

Reinstall water pump pulley hardware

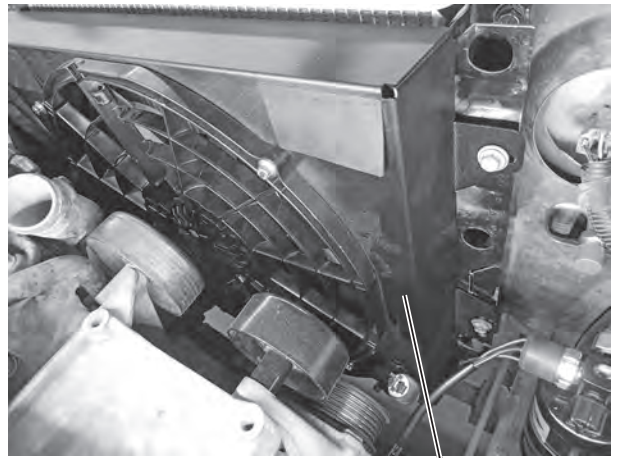

Photo 2

Install new fan assembly onto radiator using OEM fan shroud hardware.

Reinstall power steering reservoir in OEM position

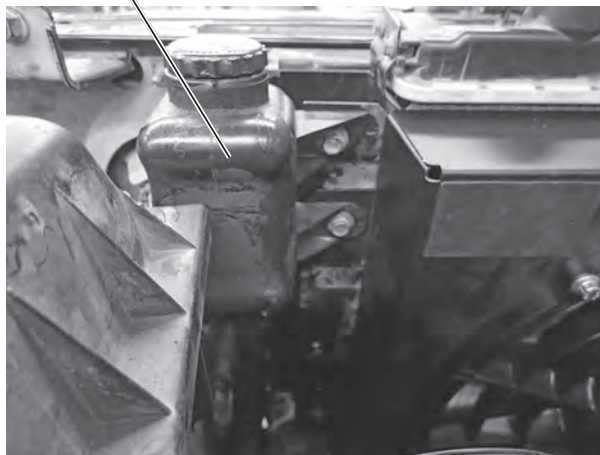

Photo 3



www.vintageair.com

Radiator Hose Modification

NOTE: Modification of the upper radiator hose will be necessary to install the adapter for the fan controller. For this application, the ground screw is not needed (See Photo 1, below).

1. Install the upper radiator hose onto the thermostat housing, then secure it with a hose clamp (See Photo 2, below).
2. Select a location for the inline hose adapter. Cut and install the inline adapter, then secure it with the provided hose clamp as shown in Photo 3, below.
3. Install the remaining portion of the radiator hose onto the adapter and radiator, then secure them with hose clamps as shown in Photo 4, below.
4. Apply thread sealant to the controller, then install it into the inline adapter (See Photos 5 and 6, below).
5. Refill the radiator with coolant at this time.

NOTE: For this application, ground screw is not needed



Photo 1

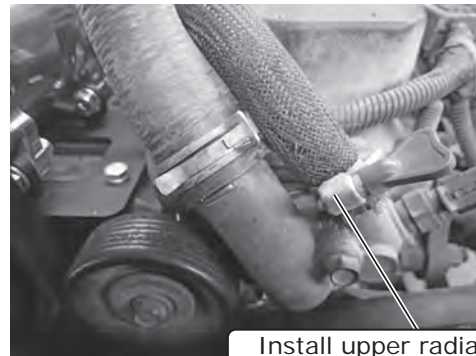

Photo 2

Install upper radiator hose onto thermostat housing, then secure it with a hose clamp

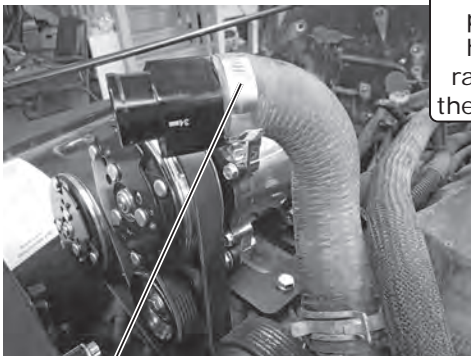

Photo 3

Install remaining portion of radiator hose onto adapter radiator, then secure them with hose clamps

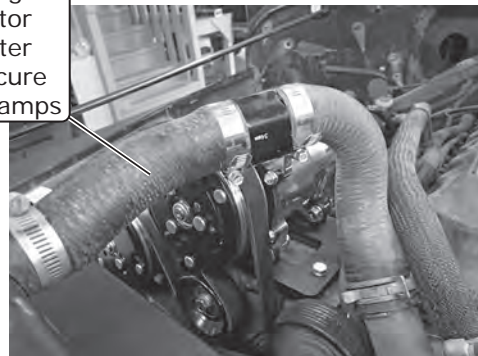

Photo 4

Select a location for inline hose adapter. Cut and install inline adapter, then secure it with a hose clamp

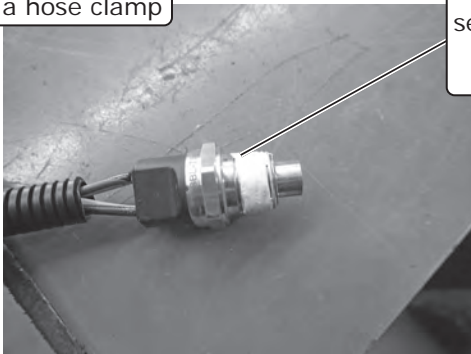

Photo 5

Apply thread sealant to controller, then install it into inline adapter

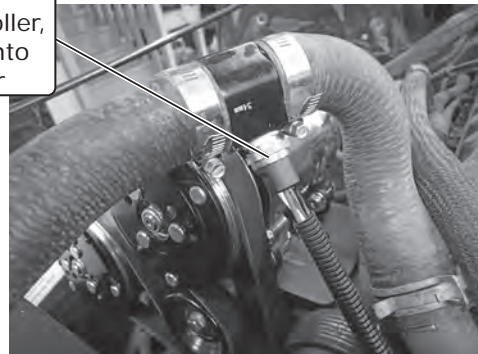

Photo 6



www.vintageair.com

Power Harness Installation

Refer to wiring schematic on Page 13.

The power harness is designed to accommodate main power connection to either the battery or the starter solenoid. Two different cables are included in this kit. PN 231084 is for the battery post connection which has a #10 ring terminal on one end, and a 5/16" ring terminal on the other. PN 231085 is for the starter solenoid connection which has a #10 ring terminal on one end, and a 3/8" ring terminal on the other.

For greater reliability and ease of installation, all but two heavy-gauge ring terminals in this kit are pre-crimped and sealed. This allows the customer to customize wire lengths as necessary and also complete installation by crimping two ring terminals, one on each power wire, and one 18GA butt splice on the control signal wire. **NOTE: Properly crimped connections are superior in electrical conductivity and durability than compared to a soldered connection. To ensure a reliable crimp, a quality crimper must be used (see Photos 1 and 2 below), and adhesive heatshrink properly sealed.**

Vintage Air recommends direct connection to the battery for vehicles with the battery located in the engine bay. For vehicles with trunk-mounted batteries, we recommend connection to the starter solenoid or battery cable stud in the engine bay.



Photo 1

Vintage Air recommends 6GA
ring terminal crimp tool,
MOLEX 19284-0034
(Not included)



Photo 2

Vintage Air recommends 6GA
ring terminal/18GA butt splice crimp tool,
VA PN 424009
(Not included)



www.vintageair.com

Power Harness Installation (Cont.)

1. Determine desired route from fan connector to your desired power source. **NOTE: Avoid routing close to a heat source such as exhaust manifolds or against heater hoses. Ensure power pigtail from fan is secured to bracket (or other nearby location) to prevent wiring from being caught in blade during operation.**
2. Set the white PWM control signal wire aside (See Page 11).
3. Assemble provided fuse and power branch, either 231084 or 231085 as shown in Photos 3 and 4, below.
4. Cut the red power wire from 231087 to desired length and strip insulation.
5. Using the provided #10 stud ring terminal, and one of the recommended Vintage Air crimp tools from Page 9, crimp the ring terminal. If using VA PN 494009 crimper, follow steps shown in Photo 5, below. Cover the ring terminal barrel with provided heat shrink and apply heat until fully sealed (See Photo 6, below).
6. Repeat Steps 4 and 5 using provided 5/16" stud ring terminal and black ground wire.
7. Finish assembling the fuse assembly, and shrink provided non-adhesive heat shrink until fitted to secure the assembly as shown in Photos 7 and 8, below.
8. The remaining white 18GA wire is the PWM control signal wire. It will be connected to either a Vintage Air supplied brushless fan control kit, or your engine controller (if compatible). **Note that few engine controllers are able to supply the required PWM control signal. See Operation and Troubleshooting sections for more detail.**

Clear side facing Up



Photo 3

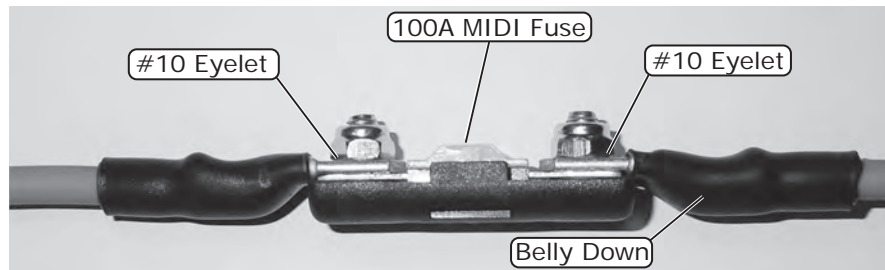

Photo 4

Crimp at 14-16mm² position, followed up by crimping at the same location on the ring terminal at the 8-10mm² position

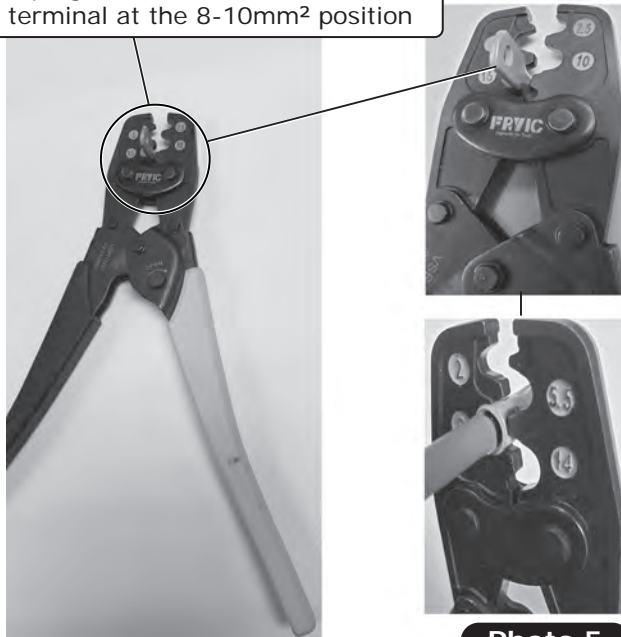

Photo 5

Make sure a good seal is formed around entire insulation



Photo 6

Proper alignment of heat shrink over fuse assembly

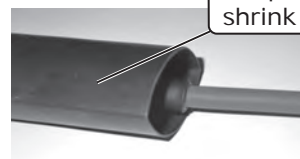

Photo 7

Properly applied heat shrink to fuse assembly



Photo 8



www.vintageair.com

Operation

Operation of Vintage Air brushless fans is different from conventional brushed fans in several ways. For instance, the brushless system contains no control relays. Instead, the battery powers the motor assembly at all times and an electric controller within the motor housing determines when to operate the motor, based on a control signal that comes in from an external source, such as the Vintage Air Brushless Fan Control Kit. This control signal is called Pulse Width Modulation (PWM), and very specific parameters need to be met in order for the fan to operate.

All Vintage Air 500W brushless fans require a PWM signal as described below:

- PWM control is "POSITIVE logic duty cycle definition" (See Figure 1, below).
- 50-150Hz PWM frequency. 100 Hz recommended.
- Duty cycle of 15-88% yields fan speed of 28-100% (See Figure 2, below).
- Fan turns off below 8% and above 98% duty cycle (cannot be "hotwired" without valid PWM signal).

When the fan is configured and operating properly, it will engage with a soft-start at approximately 30% power when the engine reaches approximately its coolant thermostat opening temperature, then gradually ramp up in speed as engine temperature further increases, until reaching maximum speed at approximately 20-25 deg. F (11-14C) higher. Since these fans are very powerful, they typically stabilize somewhere in-between, rarely if ever reaching maximum speed. **NOTE: This control strategy is ideal for cooling system performance, is typical of most modern OEM engine cooling control strategies, and is the strategy employed by all Vintage Air brushless fan controllers.**

Keep in mind, you want the fan to come on at or slightly below the thermostat setting and to be at maximum speed around 20 degrees above that. If you set the span between upper and lower temperature limits too close, or too far below the thermostat opening temperature, the fan will spend most of its time at maximum speed unnecessarily.

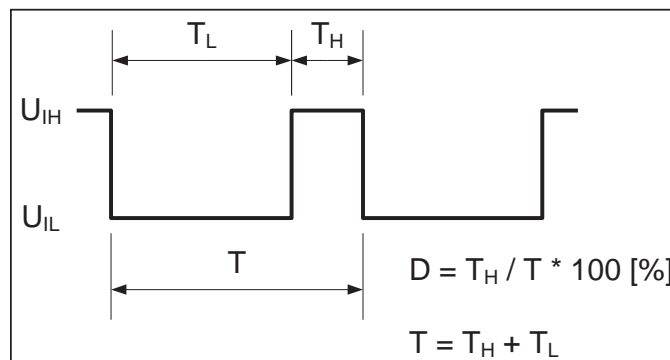

Figure 1

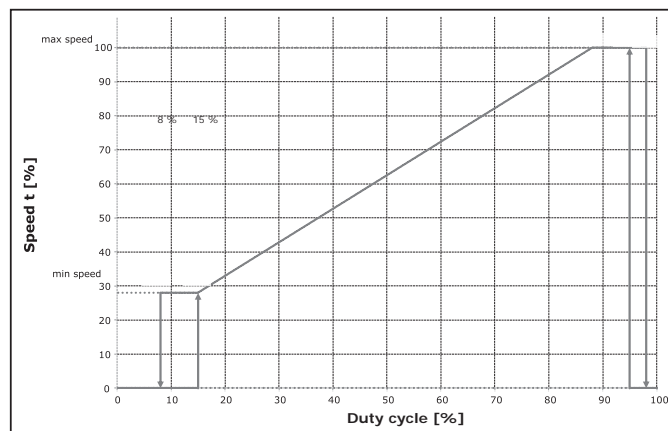

Figure 2



www.vintageair.com

Troubleshooting

WARNING: ALWAYS KEEP HANDS, CLOTHES, TOOLS, ETC. AWAY FROM THE FAN BLADE!

Brushless fans have proven to be extremely reliable when installed properly. Troubleshooting is limited to determining that the appropriate power and PWM signal is supplied to the motor.

Fan doesn't turn on:

If the fan does not come on when you expect it to, first confirm that the fan is receiving at least 12V on the red and black main power wires and that the polarity is correct. Red is positive and Black is negative. If the main fuse is determined to be blown, inspect the wiring carefully to determine if there is damage to the insulation, resulting in a short circuit. Once you have confirmed that the motor is being supplied with power, you'll need to confirm proper PWM signal to the white wire. **Note that you cannot turn the fan on by applying either 12V or ground to the white wire.**

Vintage Air Brushless Fan Control Kit equipped:

Please see troubleshooting section of your specific Vintage Air Brushless Fan Control Kit.

IMPORTANT SAFETY MESSAGE

THIS FAN CAN TURN ON WITHOUT WARNING. ALWAYS STAY CLEAR OF THE FAN BLADE WHENEVER THE BATTERY IS CONNECTED. KEEP HANDS, CLOTHING, TOOLS, ETC. CLEAR OF THE FAN BLADE AT ALL TIMES!

Owner-supplied fan controller:

Re-check your settings within your controller to confirm compliance with specifications above. Re-check all wiring. To determine whether the signal going to the fan is actually within specifications, you will need a specialized piece of test equipment called an oscilloscope. In the absence of this equipment, you can still do a simple check to determine the presence of a signal. Most digital multimeters, when connected to a PWM signal, will display a voltage value that is averaged. This allows you to estimate the duty cycle or the signal that is being transmitted to the fan. With the engine running and up to operating temperature, connect the positive probe of the multimeter to the white control wire on the fan power harness. Connect the negative probe to the ground. The displayed voltage is equal to the vehicle system voltage multiplied by the currently supplied duty cycle. For instance, if system voltage is 14V, and your multimeter is reading 7V from the signal wire, the duty cycle is 50%. If the reading is 3V, the duty cycle is around 20%. Although this is a good way to determine the presence or absence of a signal, it won't confirm whether the signal is valid. For instance, in the first example above, if the duty cycle is 50%, and signal is 500Hz, you'll get a voltage reading of 7V, but the fan won't operate because the frequency is above the maximum allowed by the fan (150Hz). This method is still useful though, as no voltage tells you definitively that you don't have a signal at all. If the fan is actually running, a reading of 7V tells you that the fan is running at 50% and so on.

Fan doesn't turn off:

Vintage Air Brushless fan controller equipped:

Please see troubleshooting section of your specific Vintage Air Brushless Fan Control Kit.



www.vintageair.com

231088 Brushless Fan Power Wiring Kit

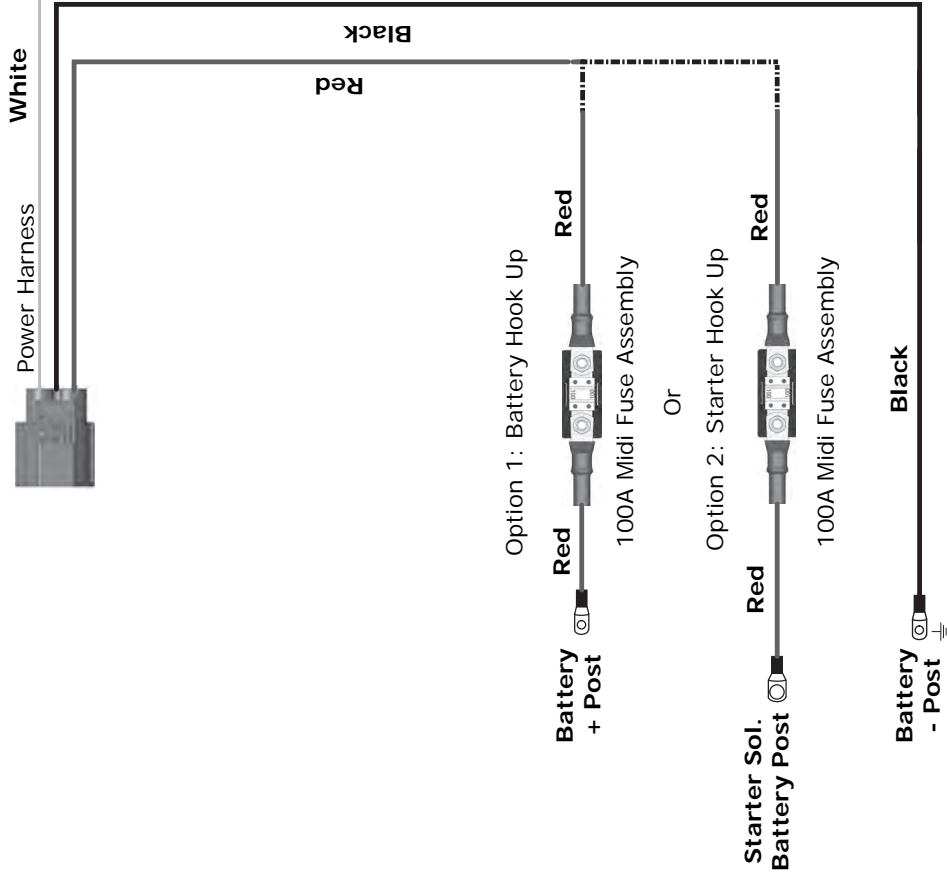

Vintage Air Brushless Fan Control Kit
(Sold Separately)

Connect to PWM control wire, color varies per kit, see Control Kit instructions for details.

NOTE: See Vintage Air Brushless Fan Control Kit Instruction set for complete control kit wiring instructions.



www.vintageair.com

Packing List: Fan/Shroud Kit (372035)

No.	Qty.	Part No.	Description
1.	1	372034	Brushless Fan Assembly
2.	1	231088	Wiring Kit, Brushless Fan Power 6GA
3.	1	701031	Hose Adapter, 34mm Joint Pipe Radiator

Checked By: _____

Packed By: _____

Date: _____

1



2

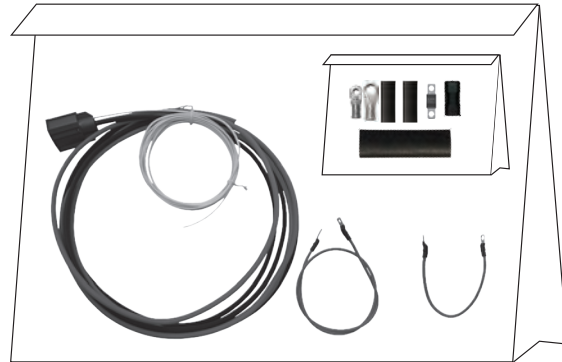

3



**NOTE: Images may not depict actual parts and quantities.
Refer to packing list for actual parts and quantities.**