

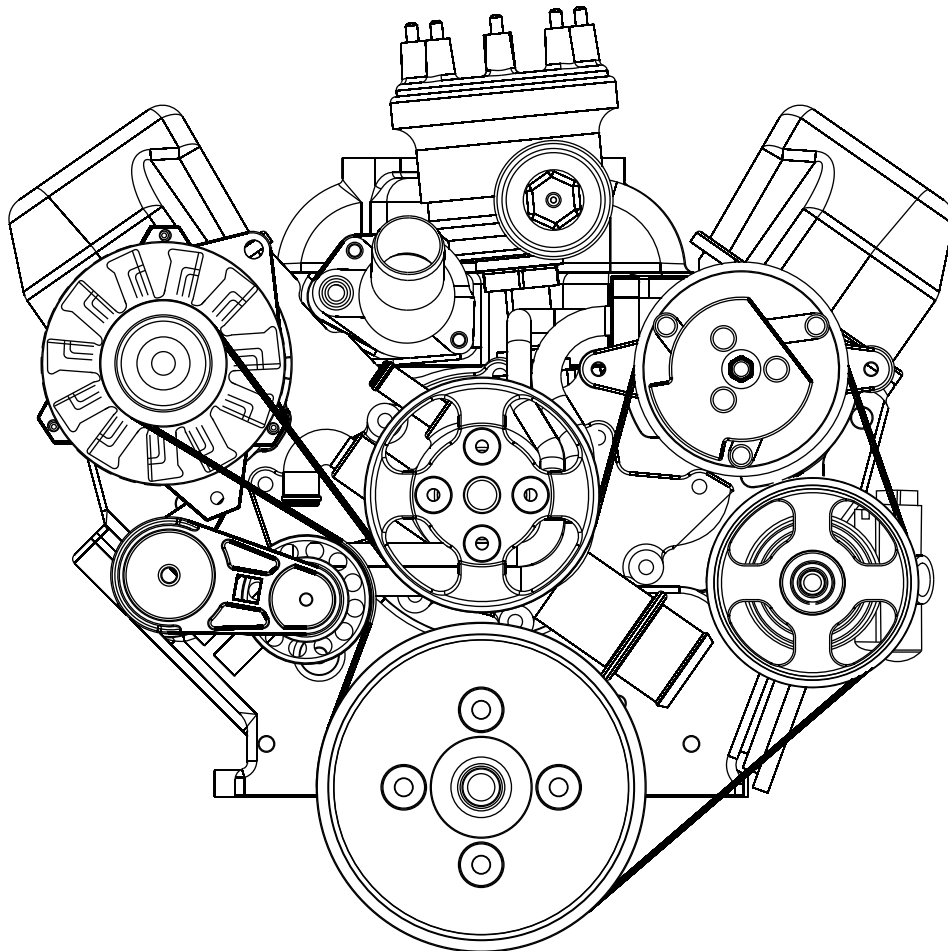

Small Block Ford

Serpentine Drive System

with & without Power Steering



18865 Goll St. San Antonio, TX 78266
Phone: 800-862-6658
Sales: sales@vintageair.com
Tech Support: tech@vintageair.com
www.vintageair.com



www.vintageair.com

Table of Contents

Cover.....	1
Table of Contents.....	2
Additional Parts & Accessories.....	3
Information Page.....	4
Important Information.....	5
OEM Front Belt System Removal.....	6
Optional Dipstick Installation, Gasket & Seal Installation.....	7
Front Runner Main Bracket Installation, Water Pump Installation.....	8
Compressor Installation, Compressor Block Fitting with Hardlines Installation.....	9
Alternator Installation, Tensioner & Tensioner Cover Installation.....	10
Water Pump & Crankshaft Pulley Installation, Power Steering Pump Installation (If Equipped).....	11
Belt Installation (With Power Steering), Belt Installation (Without Power Steering).....	12
Final Steps.....	13



www.vintageair.com

Additional Parts & Accessories

The following additional parts and accessories are available for your Front Runner drive system:

Power Steering Accessories

DSE Hose Kit

852008 Early GM (1965-81)

852009 Mustang II

852012 Ford Fox Body (1979-2004)

(Fox Body rack & pinion has external hardlines)



Steel Heater Hose Nipple

1/2" NPT for easy access on Front Runner drive installations.

501002-SUR Stainless Standard (1 3/16" length)

50101-SUR Stainless Long (2 7/8" length)

501012 Stainless 45° Angled

501011 Extended 45° Angled



Power Steering Hardline

852015 TiteFit Hardline

852016 (Black)



NOTE: Pump not included with hardline (Shown for reference only).

SuperStat Pre-Drilled Thermostat

Allows engine temperature to stabilize faster. Precisely controls amount of coolant flow, which means system cycles less often than conventional thermostats. Stainless spring.

70700-VUT 160° Thermostat

70705-VUT 180° Thermostat

70710-VUT 195° Thermostat



Flow Control Valve

852001 For Mustang II Rack & Pinion (Reduces flow to 2.0 GPM)



Banjo Fitting

852010 For DSE Hose Kit (High-pressure outlet)

Banjo Fitting

852011 For -6AN Fitting



Compressor Block Fittings

342310 Front Runner TiteFit Line Kit

342311 Front Runner TiteFit Line Kit, fully polished as shown





www.vintageair.com

Important Notice—Please Read

For Maximum System Performance, Vintage Air Recommends the Following:

The compressor and alternator supplied with this kit are grounded first via their respective mounting brackets, then to the engine block, and finally to the vehicle chassis. Inspect all mating surfaces to ensure a clean, metallic surface. This may require the removal of paint, corrosion or anodizing from several locations in order to complete the grounding path. In addition, the supplied 4 AWG cable or equivalent must be used to both ensure proper charging and prevent damage and/or fire.

After installation, it will be necessary to confirm the quality of the ground and power paths by measuring voltage drop between the electrical components and the battery terminals while operating the alternator at or near its rated load (refer to the diagram provided with the alternator installation instructions).

Refrigerant Capacities:

Vintage Air System: 1.8 lbs. (1 lb., 12 oz.) of **R134a**, charged by weight with a quality charging station or scale. **NOTE: Use of the proper type and amount of refrigerant is critical to system operation and performance. Vintage Air systems are designed to operate with R134a refrigerant only. Use of any other refrigerant could damage your A/C system and/or vehicle, and possibly cause a fire, in addition to potentially voiding the warranties of the A/C system and its components.**

Other Systems: Consult manufacturer's guidelines.

Lubricant Capacities:

New Vintage Air-supplied Sanden Compressor: No additional oil needed (Compressor is shipped with proper oil charge).

All Other Compressors: Consult manufacturer (Some compressors are shipped dry and will need oil added).

Service Info:

Protect Your Investment: Prior to assembly, it is critical that the compressor, evaporator, A/C hoses and fittings, hardlines, condenser and receiver/drier remained capped. Removing caps prior to assembly will allow moisture, insects and debris into the components, possibly leading to reduced performance and/or premature failure of your A/C system. This is especially important with the receiver/drier.

Additionally, when caps are removed for assembly, **BE CAREFUL!** Some components are shipped under pressure with dry nitrogen.

Evacuate the System for 35-45 Minutes: Ensure that system components (Drier, compressor, evaporator and condenser) are at a temperature of at least 85° F. On a cool day, the components can be heated with a heat gun **or** by running the engine with the heater on before evacuating. Leak check and charge to specifications.



www.vintageair.com

Important Information Before Beginning:

- Read instructions completely and thoroughly before installing the Vintage Air Front Runner system. Follow instructions step-by-step for proper installation.
- On 260 or 289 (including high-performance) engines from 1962-64, there may be an oil fill opening on the engine block that is not covered by the Front Runner main bracket (See Photo 1, below). While it is the customer's responsibility to determine how to plug or seal the opening, Vintage Air recommends having the opening sealed by an automotive engine machine shop. Be sure there is an oil fill cap in the valve cover for adding oil once the block opening has been sealed.
- Prior to installation, run a tap through all mounting holes in the block.
- Anti-seize must be used on all bolt threads, or mechanical locking will occur, preventing removal of nuts from bolts and causing damage to fasteners.
- Use of an electric fuel pump will be necessary after the Front Runner is installed.
- If using the Ford Performance Boss 302 crate engine, it may be necessary to enlarge the lower timing cover holes to accept a 3/8" bolt instead of the traditional 5/16" bolt. If using the harmonic balancer that came with the Ford Performance Boss 302, it may be necessary to trim the lower water pump bolt and casting for clearance.

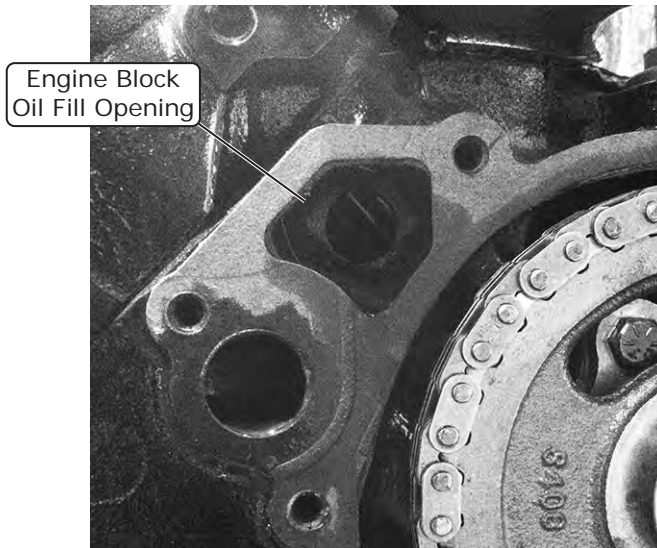

Photo 1



www.vintageair.com

OEM Front Belt System Removal

Perform the Following:

1. Disconnect the negative battery cable.
2. Drain the radiator.
3. Drain the engine oil.
4. Remove the fan, fan shrouds and belts.
5. Remove the alternator, A/C compressor and brackets.
6. Remove the crankshaft pulley and the harmonic balancer. **NOTE: This system is designed to use the stock Ford harmonic balancer. Before removing the harmonic balancer, verify that the dimensions from the face of the block to the machined pulley mounting surface of the balancer is 4.725" (4 3/4"). Measure as shown in Figure 1, below (measure from the shaded surfaces). If using a Ford Motorsports balancer, a Ford Motorsports balancer spacer kit (199002-HFA) will need to be purchased from Vintage Air.**
7. Remove the OEM water pump and thermostat.
8. Remove the motor mount bolts and lift the engine high enough to drop the oil pan.
9. Using the proper equipment, support the engine.
10. Drop the oil pan. **NOTE: Be careful to avoid damaging the oil pan gasket.**
11. Remove the OEM timing cover and timing position indicator (retain indicator).
12. Remove the fuel pump eccentric and oil slinger (if equipped).
13. Remove all excess timing cover gasket material from the front of the block.

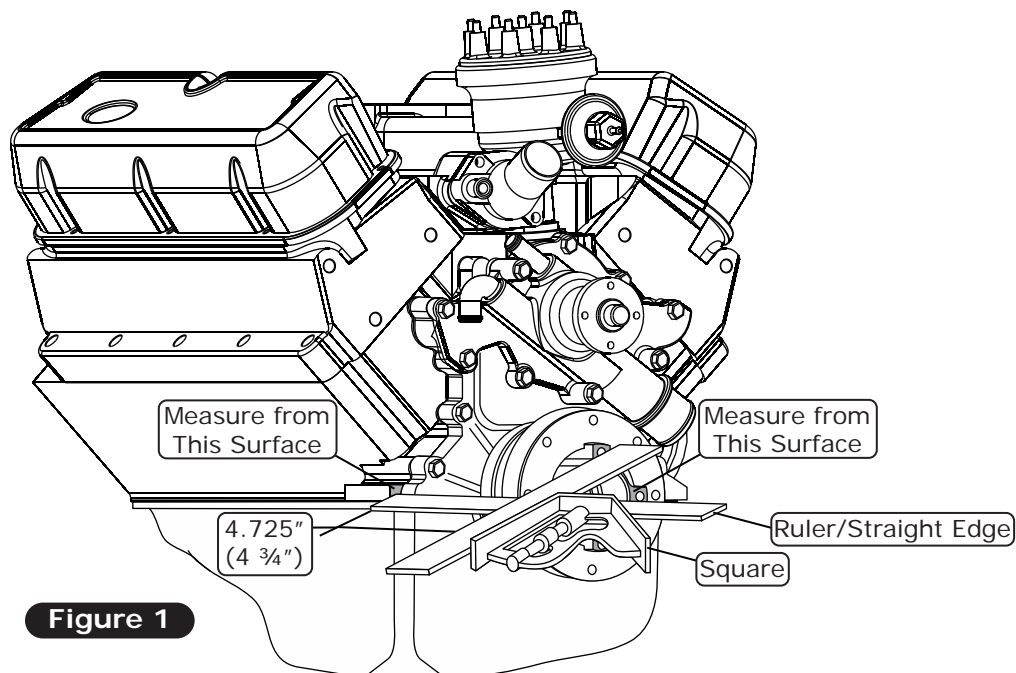



www.vintageair.com

Optional Dipstick Installation

1. To install the dipstick, refer to the installation instructions supplied with the dipstick kit.

Dipstick Mounting Location
on Back Side of Front Runner
Main Bracket

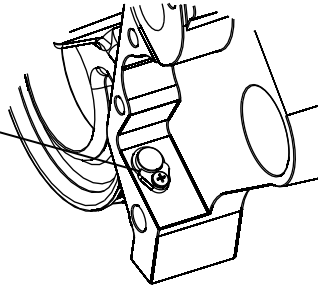

Gasket & Seal Installation

1. Using a suitable seal installation tool, install the crankshaft seal (supplied) into the Front Runner main bracket.
NOTE: The seal cannot be hammered in. If the correct seal installation tool is not available, take the main bracket and seal to a local automotive parts retailer to have the seal installed.
2. Using a suitable gasket adhesive, apply a bead of adhesive to the back side of the main bracket mounting surface. Install the timing cover gasket (supplied) as shown in Figure 2, below.
3. Apply a bead of gasket adhesive to the back side of the water pump mounting surface. Install the water pump gasket (supplied with the water pump) as shown in Figure 2, below.
4. Using a suitable high-temperature RTV silicone, apply silicone to the timing cover/oil pan gasket locators on the bottom side of the Front Runner main bracket (See Figure 3, below).
5. Using a suitable gasket adhesive, apply a bead of adhesive to the oil pan surface and install the oil pan gasket (supplied) (See Figure 3a, below).

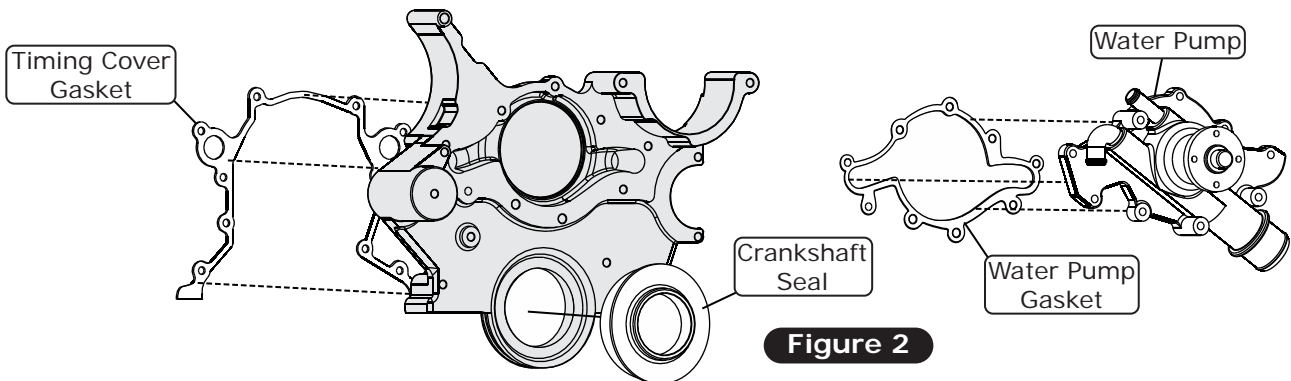

Figure 2

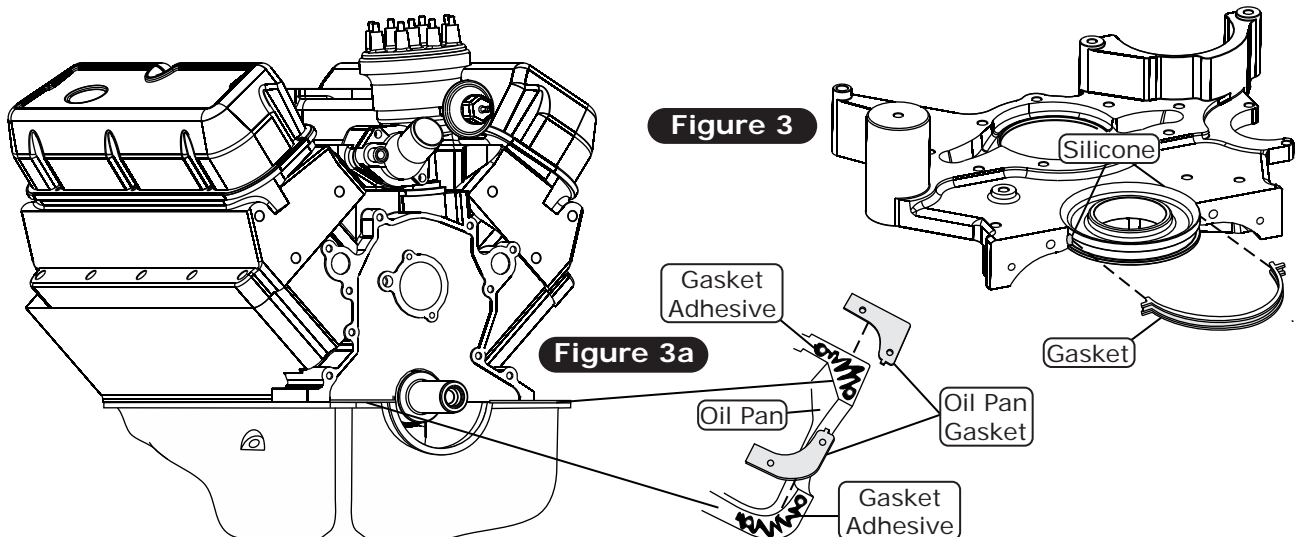

Figure 3

Figure 3a



www.vintageair.com

Front Runner Main Bracket Installation

1. Install the Front Runner main bracket as shown in Figure 4, below. **NOTE: Make sure the timing cover/oil pan gasket is aligned properly.**
2. Secure the Front Runner main bracket using (4) 5/16-18 x 2 1/2" SS 12-Pt bolts as shown in Figure 4, below. Torque to 20 lb ft. **NOTE: Install the timing indicator as shown in Figure 4, below.**
3. Install the oil pan. Torque to 10-12 lb ft. **NOTE: Make sure the oil pan gasket is aligned properly.**

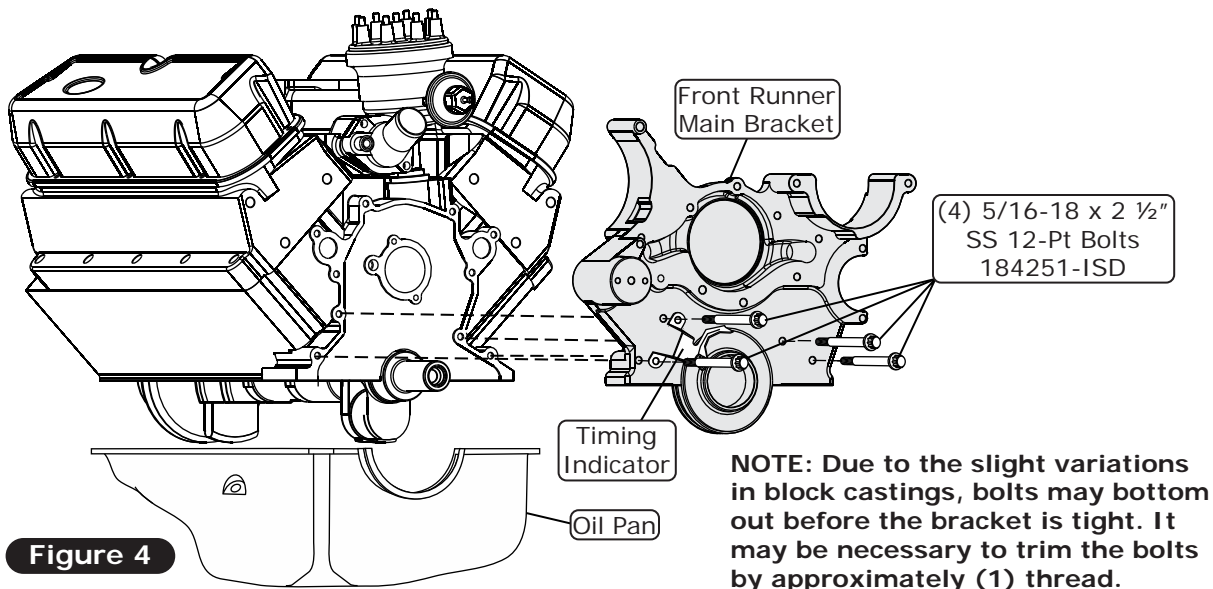

Figure 4

Water Pump Installation

1. Install the water pump as shown in Figure 5, below. **NOTE: Make sure the water pump gasket is aligned properly.** Secure the water pump using bolts as shown in Figure 5, below. Torque to 18 lb ft.
2. Install the harmonic balancer. Torque to 90-100 lb ft. **NOTE: If using a Ford Motorsports balancer, see instructions included with hardware kit 199002-HFA.**

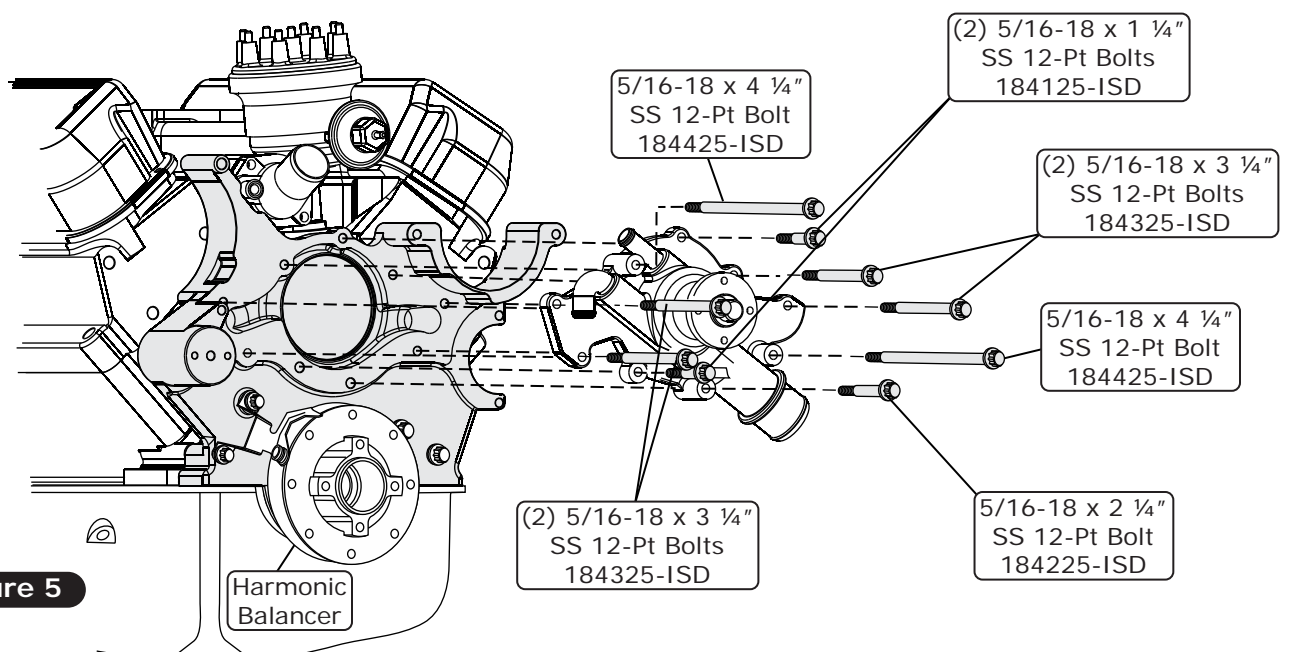

Figure 5

Compressor Installation

1. Install the compressor as shown in Figure 6, below. Secure the compressor to the main bracket using (2) 5/16-18 x 4 1/4" SS 12-Pt bolts, (2) 5/16" AN flat washers and (2) 5/16-18 nyloc nuts as shown in Figure 6, below. The compressor mounting ears contain sliding bushings that are drawn in and clamp to the bracket when compressed. Torque to 25 lb ft.

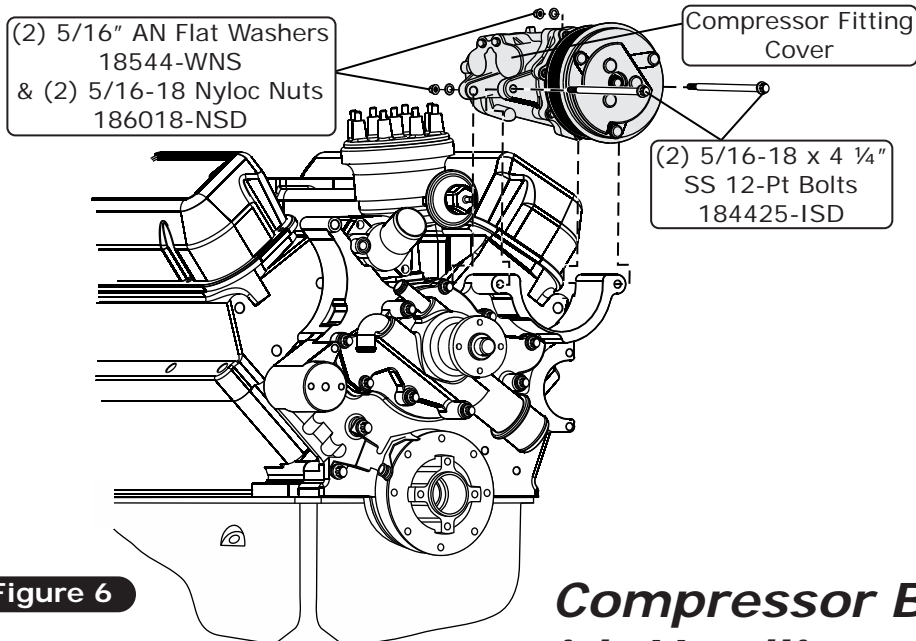

Figure 6

Compressor Block Fitting with Hardlines Installation

1. Remove the compressor fitting cover (discard cover and screws) and apply a coat of PAG oil around the O-rings (See Figure 6, above, and Figure 7, below).
2. Using (2) 8mm-1.25 x 20mm SS socket head cap screws, install the compressor block fitting with hardlines as shown in Figure 7, below. Torque to 18 lb ft.
3. Secure the hardlines to the main bracket using the hardline bracket and a 1/4-20 x 3/4" SS flat socket cap screw (See Figure 7, below).

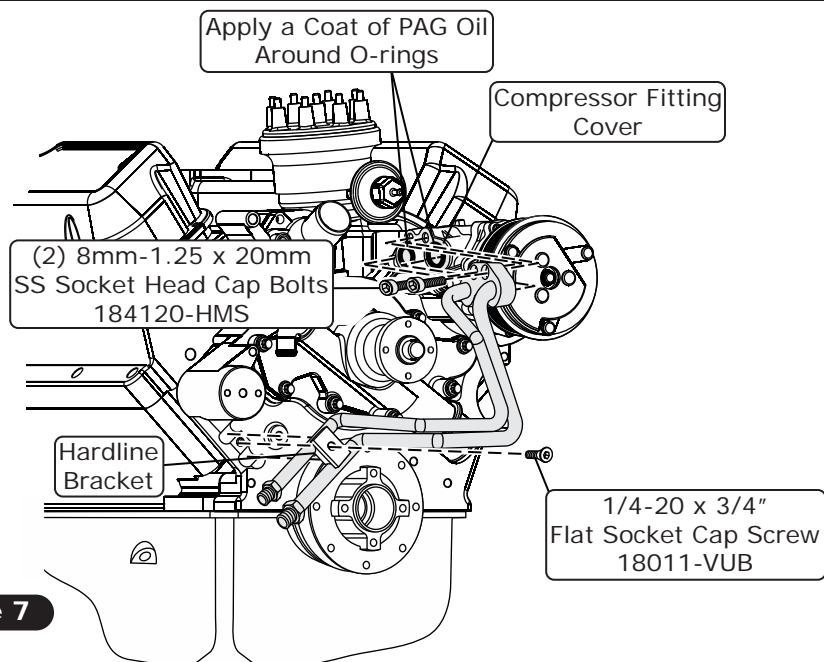

Figure 7

Alternator Installation

1. Install the alternator onto the Front Runner main bracket and secure using a 3/8-16 x 4 1/4" SS 12-Pt Bolt and a 5/16-18 x 1 1/4" SS 12-Pt bolt as shown in Figure 8, below. Torque to 24-28 lb ft.

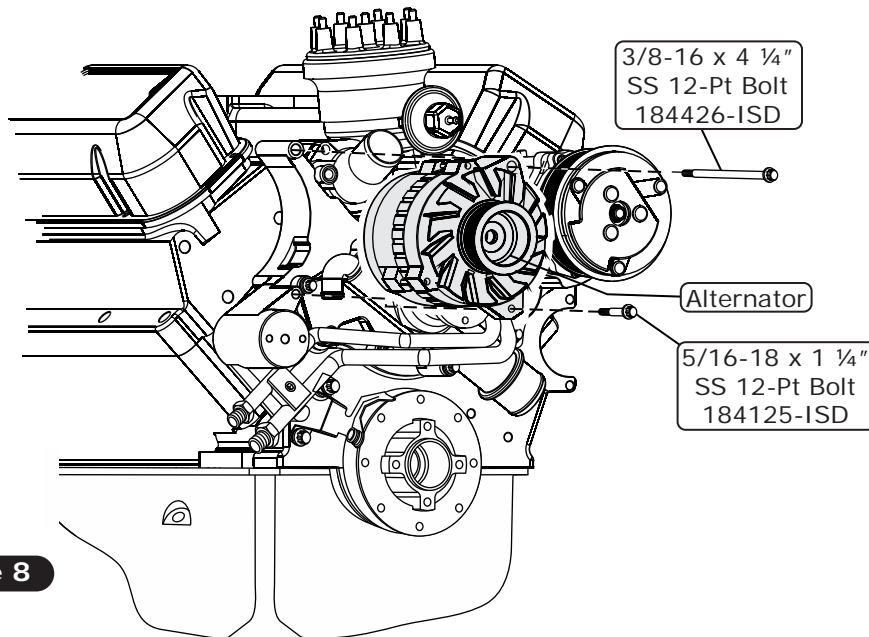

Figure 8

Tensioner & Tensioner Cover Installation

NOTE: See tensioner cover installation instructions supplied with the tensioner cover.

1. Remove the tensioner roller and install the tapered block nut into the back side of the tensioner (lightly tap into place). **NOTE: For the tapered block nut to fit properly, it may be necessary to use a file to remove excess metal flashing around the square opening.**
2. Reinstall the tensioner roller onto the tensioner.
3. Install the tensioner using a 3/8-16 x 2 1/2" SS 12-Pt bolt as shown in Figure 9, below. Torque to 21 ± 2 lb ft.

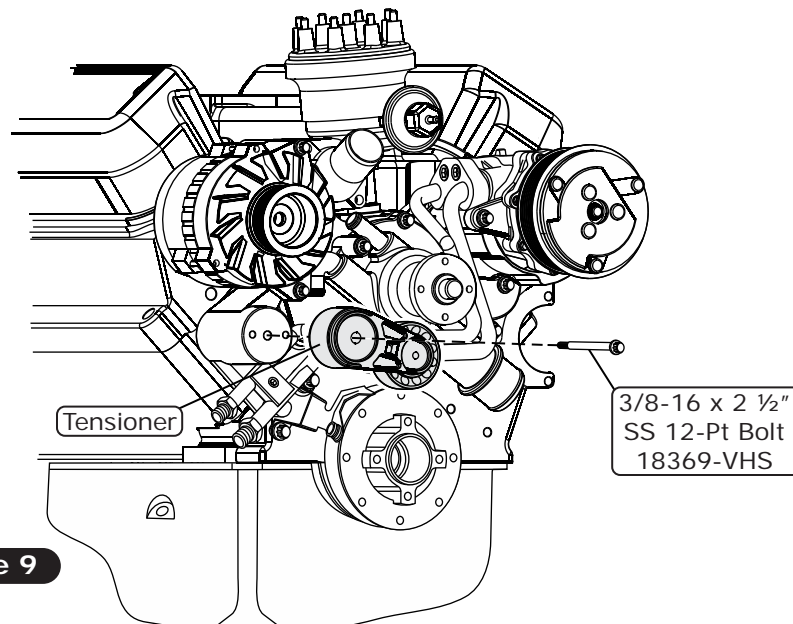

Figure 9



www.vintageair.com

Water Pump & Crankshaft Pulley Installation

1. Install the crankshaft pulley using (4) 3/8-16 x 1 1/4" SS 12-Pt bolts as shown in Figure 10, below. Torque to 25 lb ft.
2. Install the water pump pulley using (4) 5/16-24 x 3/4" SS 12-Pt bolts as shown in Figure 10, below. Torque to 22 lb ft.

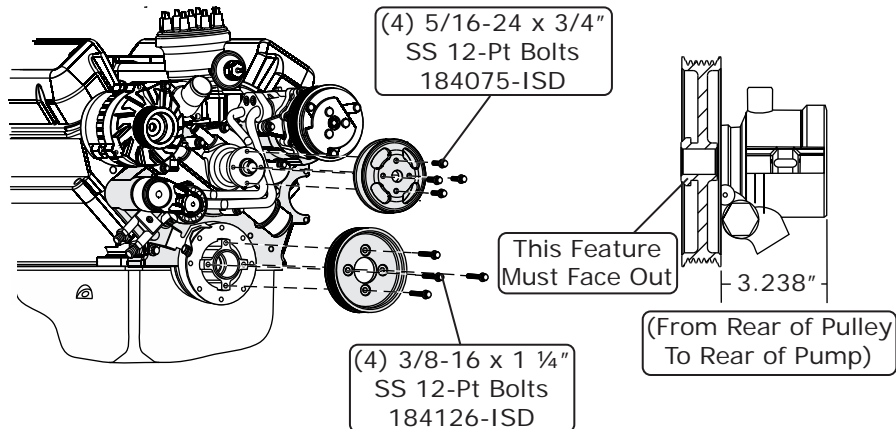

Figure 10

Power Steering Pump Installation (If Equipped)

WARNING: The pulley must be installed with the proper tool (K-D Tool #2897 or equivalent). Do not attempt to hammer or press the pulley onto the power steering pump shaft! Failure to use the proper tool will destroy the pump.

NOTES:

- A high-pressure fitting (not included with this kit) is required for hose connection. Several options are available through Vintage Air (See Additional Parts & Accessories on Page 3 of this instruction booklet).
 - TC power steering pump flow rate is 3.0 to 3.4 gallons per minute at 1500 RPM. For rack-and-pinion systems that require a lower flow rate, a flow control valve (Vintage Air Part # 852001) may be purchased to reduce the flow to 2.0 GPM (See Additional Parts & Accessories on Page 3). Consult with the rack manufacturer to determine flow rate requirements.
 - To ensure the functionality and longevity of the power steering pump, proper bleeding of the system is required at the time of installation. See the attached document for power steering system bleeding instructions.
1. Using a power steering pump pulley installer, install the power steering pulley onto the power steering pump, leaving the pulley in line with the water pump pulley.
 2. Install the power steering pump using (2) 5/16-18 x 3 1/2" SS 12-Pt bolts, (2) 5/16" AN flat washers and (2) 5/16-18 nyloc nuts as shown in Figure 11, below. Torque to 28 lb ft.

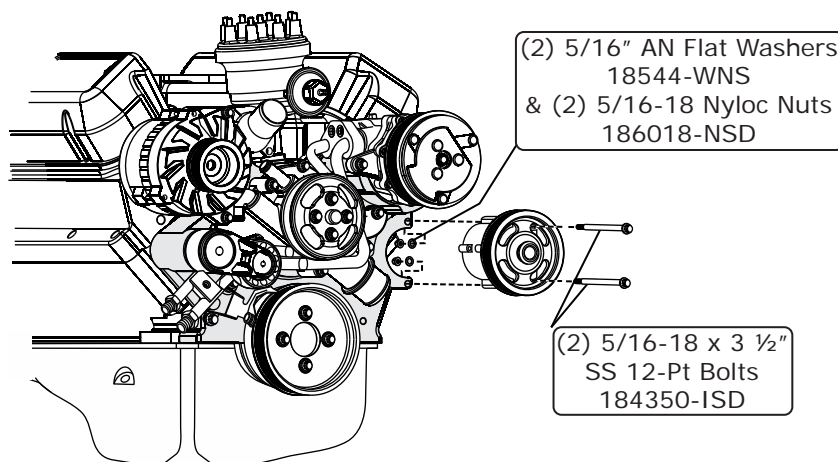

Figure 11



www.vintageair.com

Belt Installation (With Power Steering)

1. Insert a 1/2"-drive ratchet or breaker bar into the socket on the tensioner, and rotate it clockwise to the tensioner stop. Route the belt around the crankshaft pulley, power steering pulley and alternator, and over the compressor. Finally, pull the belt down and slide it under the water pump pulley (See Figure 12, below).

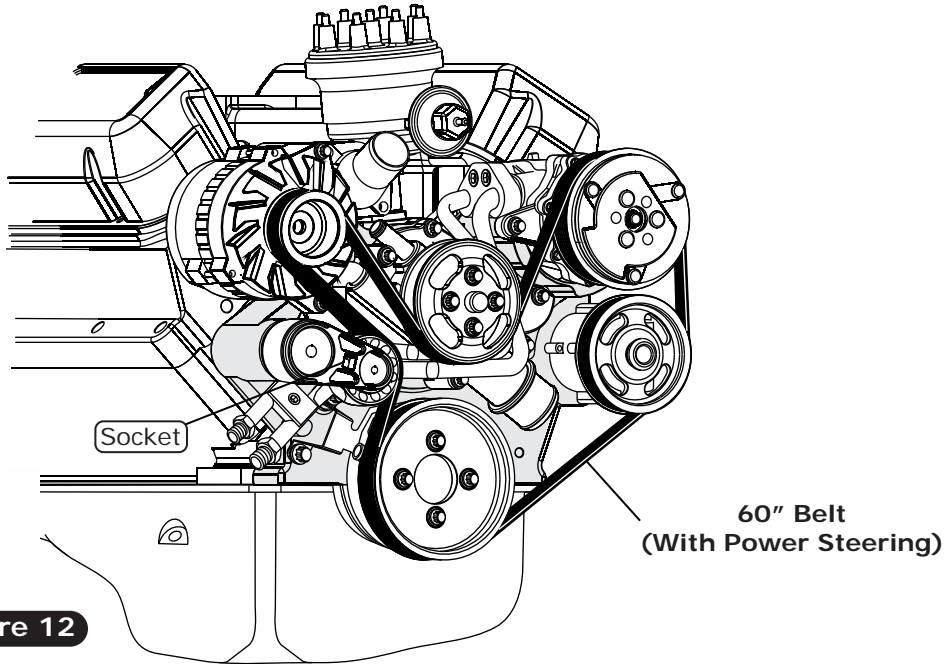

Belt Installation (Without Power Steering)

1. Insert a 1/2"-drive ratchet or breaker bar into the socket on the tensioner, and rotate it clockwise to the tensioner stop. Route the belt around the crankshaft pulley and alternator, and over the compressor. Finally, pull the belt down and slide it under the water pump pulley (See Figure 13, below).

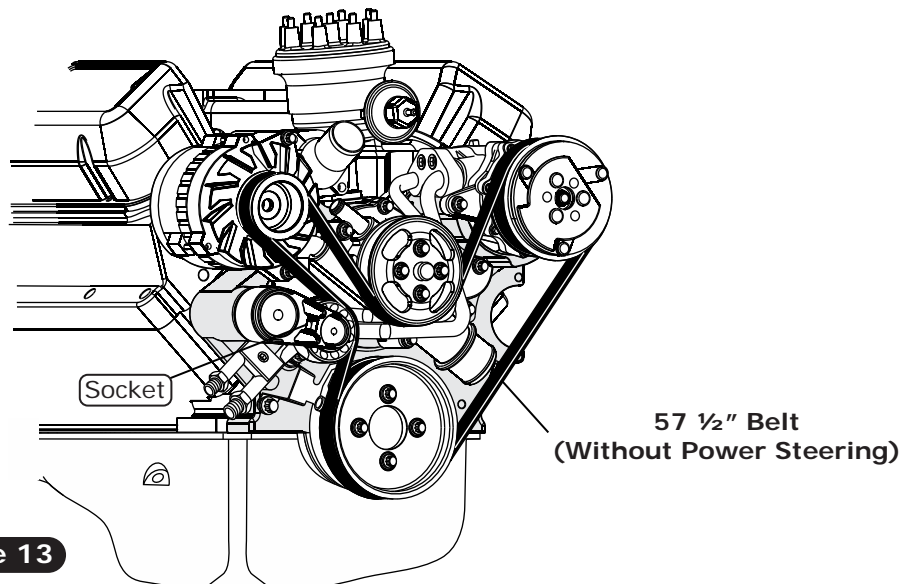



www.vintageair.com

Final Steps

1. Install the tensioner cover and compressor cover (See instructions supplied with covers) (See Figure 14, below).
2. Connect the heater hoses to the water pump.
3. Reinstall all previously removed items.
4. Reconnect all electrical connectors. **NOTE: The charging system must be properly wired to accept a one-wire internally regulated alternator.**
5. Connect the negative battery cable.
6. Fill radiator with at least a 50/50 mixture of approved antifreeze and distilled water. It is the owner's responsibility to keep the freeze protection at the proper level for the climate in which the vehicle is operated. Failure to follow antifreeze recommendations will cause heater core to corrode prematurely and possibly burst in A/C mode and/or freezing weather, voiding your warranty.
7. Double check all fittings, brackets and belts for tightness.
8. Vintage Air recommends that all A/C systems be serviced by a licensed automotive A/C technician.
9. To ensure the functionality and longevity of the power steering pump, proper bleeding of the system is required at the time of installation. See the attached document for power steering system bleeding instructions.
10. Evacuate the system for a minimum of 45 minutes prior to charging, and perform a leak check prior to servicing.
11. Charge the system to the capacities stated on Page 4 of this instruction manual.

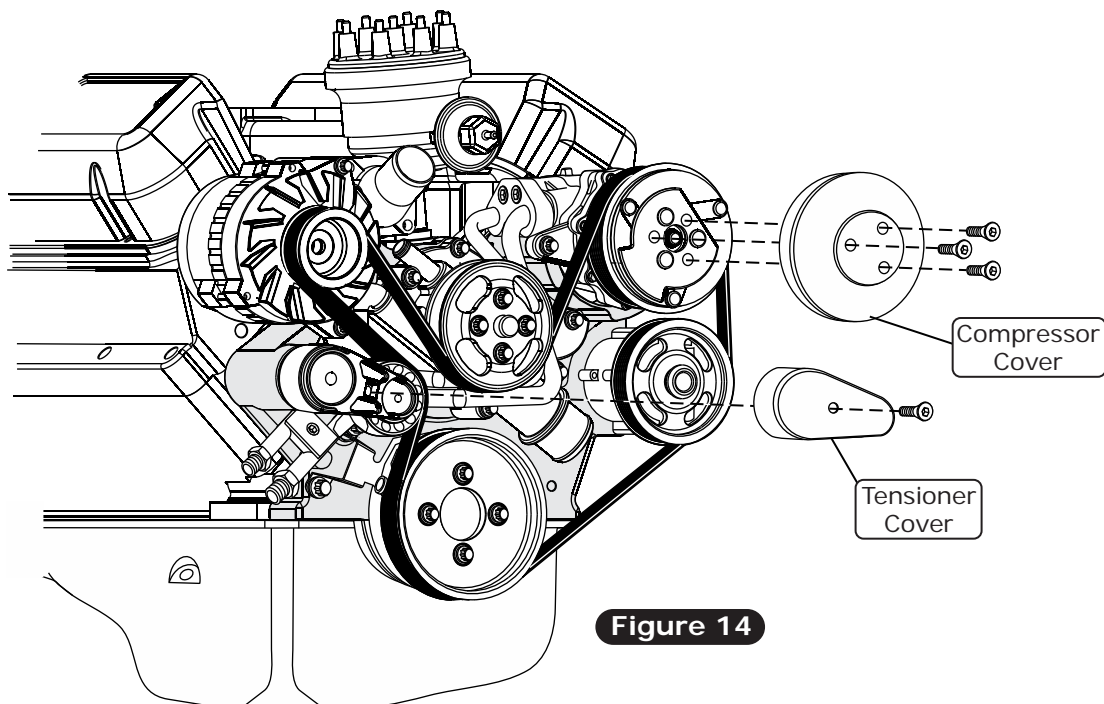

Figure 14



www.vintageair.com

Packing List: Chrome Front Runner™ Kit (176017) Small Block Ford with Power Steering

No.	Qty.	Part No.	Description
1.	1	176303-SFA	Bracket Assembly, Main, Polished
2.	1	733003-WFC	Pulley, Water Pump
3.	1	733004-CFC	Pulley, Crankshaft/Harmonic Balancer
4.	1	733005-PFC	Pulley, Power Steering
5.	1	39603-SCH	Tensioner
6.	1	199001-HFA	Hardware Kit
7.	1	72600-MWR	Belt, 60" Serpentine
8.	1	721000-SFR	Water Pump
9.	1	081104-UBQ	Fitting with Hardlines, Compressor Block, Polished
10.	1	189104-MUP	Line Clamp, Polished
11.	1	331103-VGA	Gasket Kit
12.	1	042921	Alternator, 170-Amp, Chrome
13.	1	046770	Compressor, 6.1 CID Drilled Multi-Groove, Chrome
14.	1	398002	Tensioner Cover Assembly, Chrome
15.	1	044095	Clutch Cover Assembly, Chrome
16.	1	851001	Power Steering Pump with Integrated Reservoir
17.	1	220013	Alternator Cable Kit

Checked By: _____
Packed By: _____
Date: _____

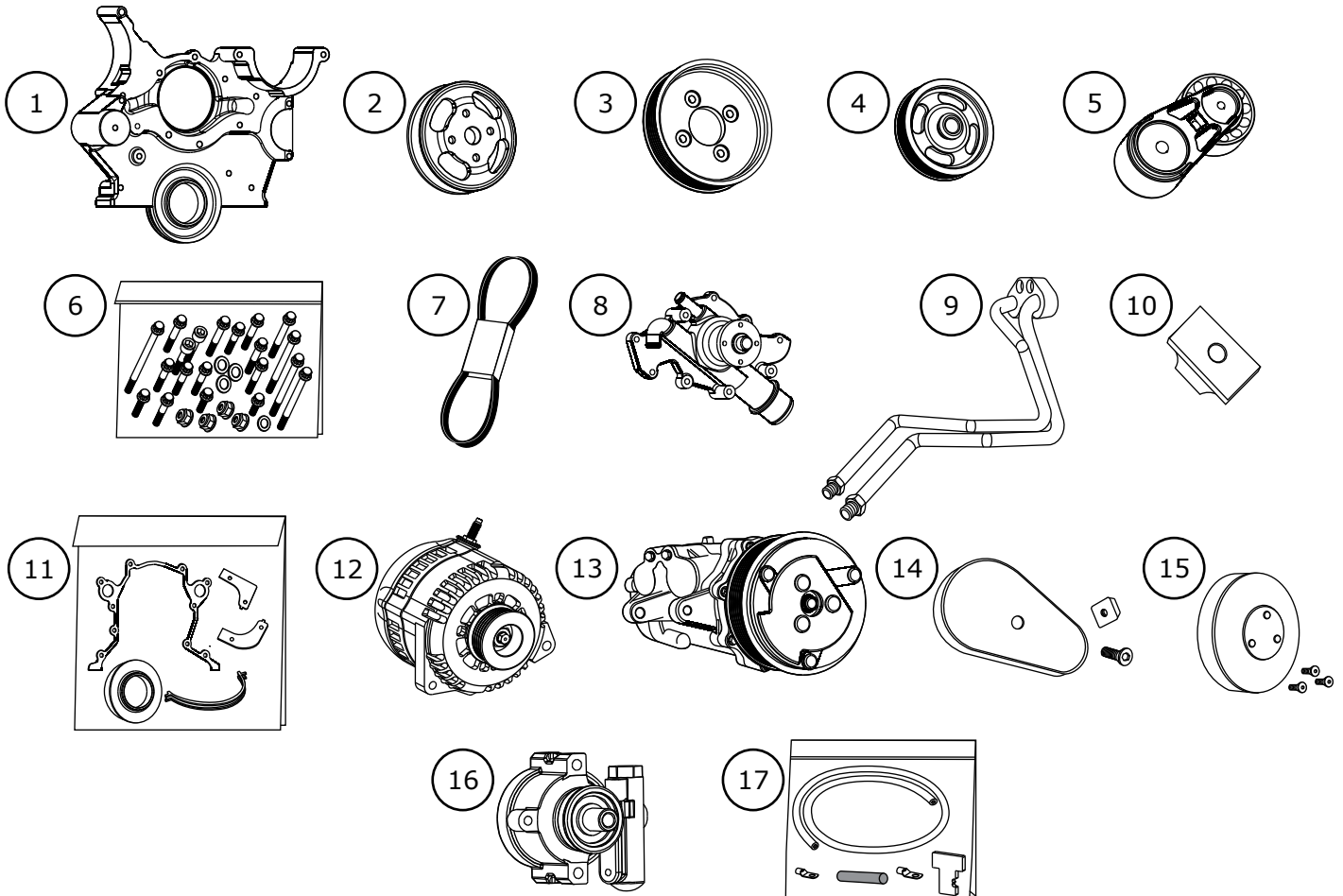

**NOTE: Images may not depict actual parts and quantities.
Refer to packing list for actual parts and quantities.**