



an ISO 9001:2008 Registered Company

1966-68 Mopar B-Body

Water Pump Tensioner Kit

with 383-440 Engine
(166009)

Please Note:

This Kit is Designed to Fit 1966-68 Mopar B-Body Vehicles *with* 383-440 Engines *and* One of the Following Configurations:

A. With OEM Single-Groove Water Pump Pulley

B. Without Power Steering and in Conjunction with Vintage Air Compressor/Alternator Bracket Kit #161002

If Your Vehicle Does Not Match These Criteria, Modifications May Be Required for Kit to Fit Properly.

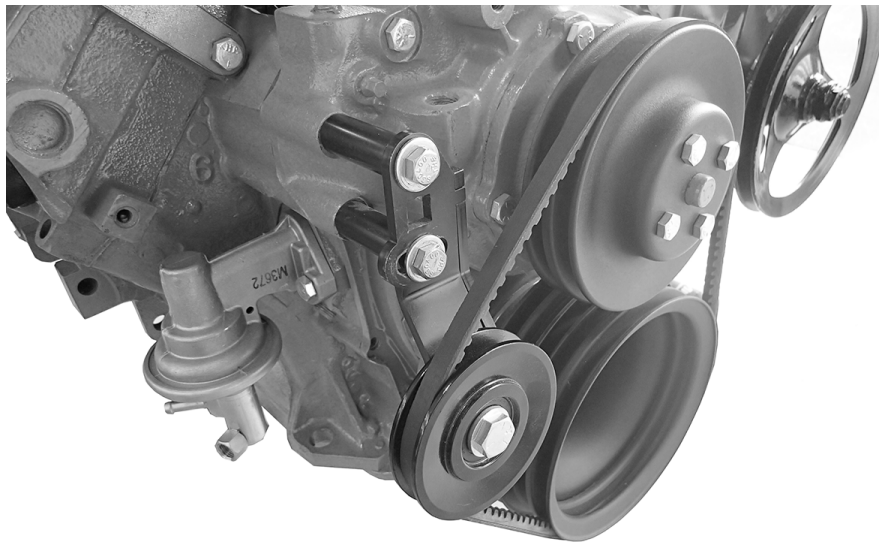

18865 Goll St. San Antonio, TX 78266

Phone: 800-862-6658

Sales: sales@vintageair.com

Tech Support: tech@vintageair.com

www.vintageair.com



www.vintageair.com

Table of Contents

Cover.....	1
Table of Contents.....	2
Packing List/Parts Disclaimer.....	3
For Use with OEM Single-Groove Water Pump Pulley.....	4
For Use with OEM Single-Groove Water Pump Pulley (Cont.).....	5
For Use with Vintage Air Bracket Kit #161002.....	6
For Use with Vintage Air Bracket Kit #161002 (Cont.).....	7
Packing List.....	8



www.vintageair.com

Packing List: Water Pump Tensioner Kit (166009)

No.	Qty.	Part No.	Description
1.	1	166008	Bracket, Water Pump Tensioner
2.	1	191041	Hardware Kit

**** Before beginning installation, open all packages and check contents of shipment. Please report any shortages directly to Vintage Air within 15 days. After 15 days, Vintage Air will not be responsible for missing or damaged items.**

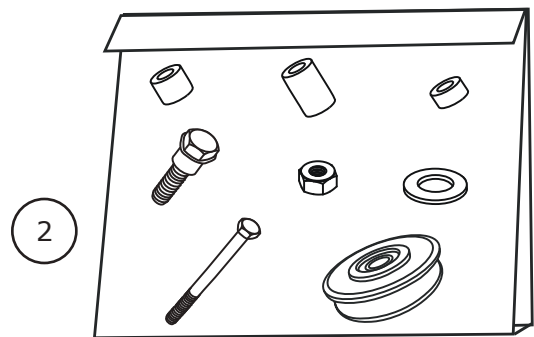
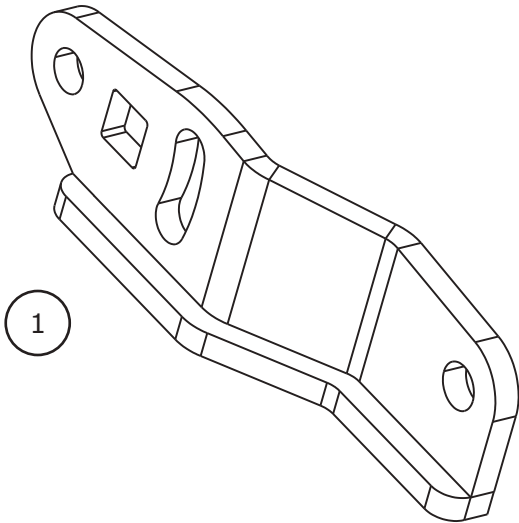

**NOTE: Images may not depict actual parts and quantities.
Refer to packing list for actual parts and quantities.**



www.vintageair.com

For Use with OEM Single-Groove Water Pump Pulley

1. Remove the fan and fan clutch for better access to the tensioner.
2. Loosen the (2) passenger side water pump bolts to relieve belt tension.
3. Remove the belt.
4. Remove the (2) passenger side water pump bolts, along with the factory spacer and tensioner bracket (discard).
5. Assemble the supplied tensioner pulley and tensioner bracket using the shoulder bolt, the .250" L spacer, and the 7/16-20 locknut as shown in Photo 1, below. Ensure the spacer is between the bracket and the pulley, and tighten the assembly.
6. Insert (2) 3/8-16 x 5" hex bolts with 3/8" washers through the tensioner bracket as shown in Photo 2, below. Install (2) 2.07" L spacers onto the bolts (See Photo 2, below).
7. Thread the (2) 3/8-16 x 5" hex bolts into the water pump (See Photo 3, below). **NOTE: Tighten only the upper bolt at this time.**

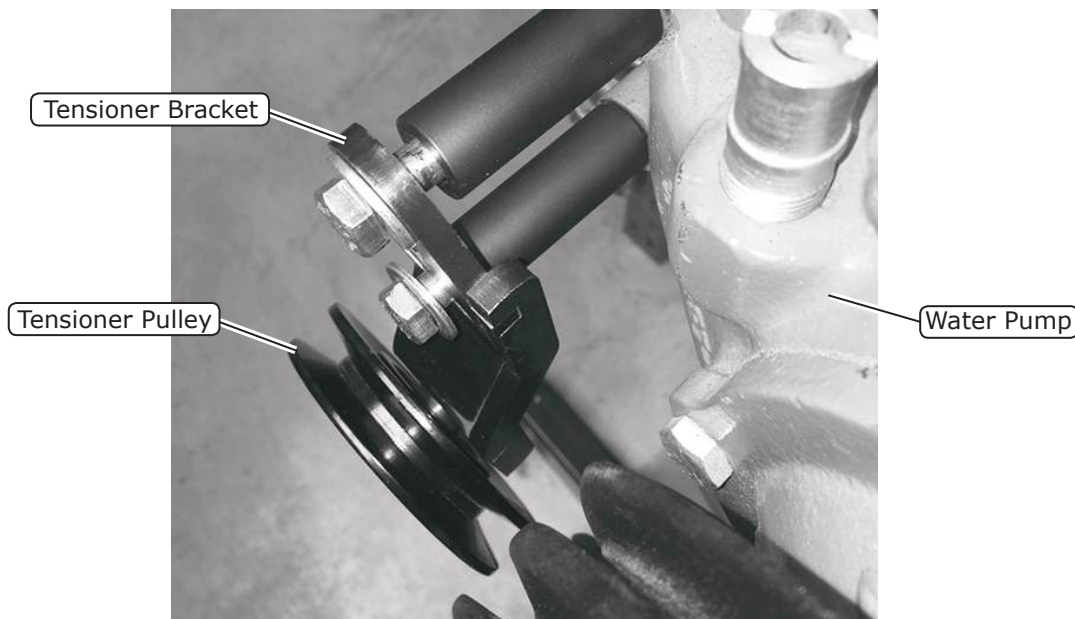
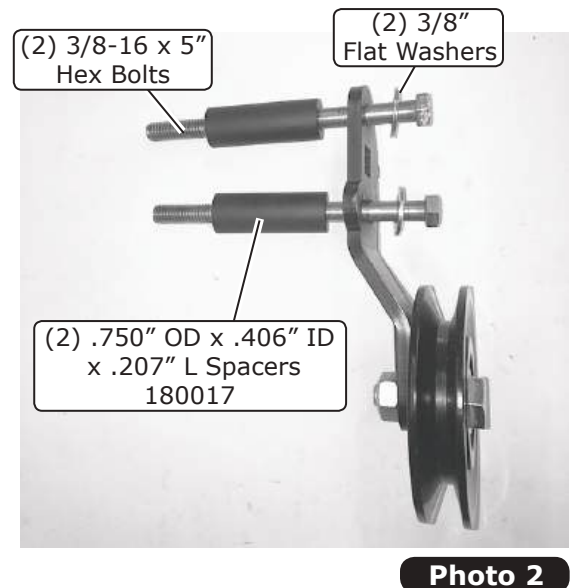
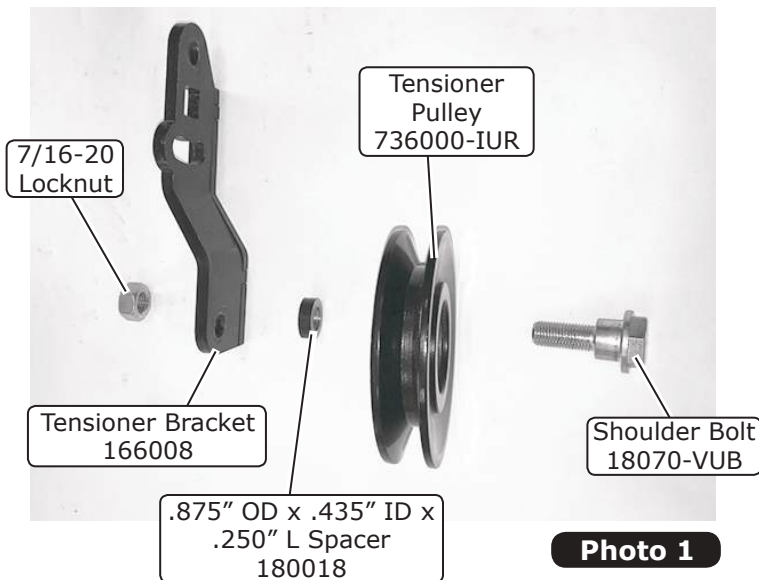



www.vintageair.com

For Use with OEM Single-Groove Water Pump Pulley (Cont.)

8. Reinstall the belt onto the tensioner pulley, the crankshaft and the water pump. **NOTE: The belt installs onto the front crankshaft pulley groove (See Photo 5, below).**
9. Tension the belt using a 1/2" ratchet handle in the square hole on the bracket (See Photo 5, below). With the belt at the proper tension, tighten the lower bolt on the tensioner bracket (See Photo 4, below).
10. Tighten any remaining bolts, and reinstall the fan and fan clutch (if removed).

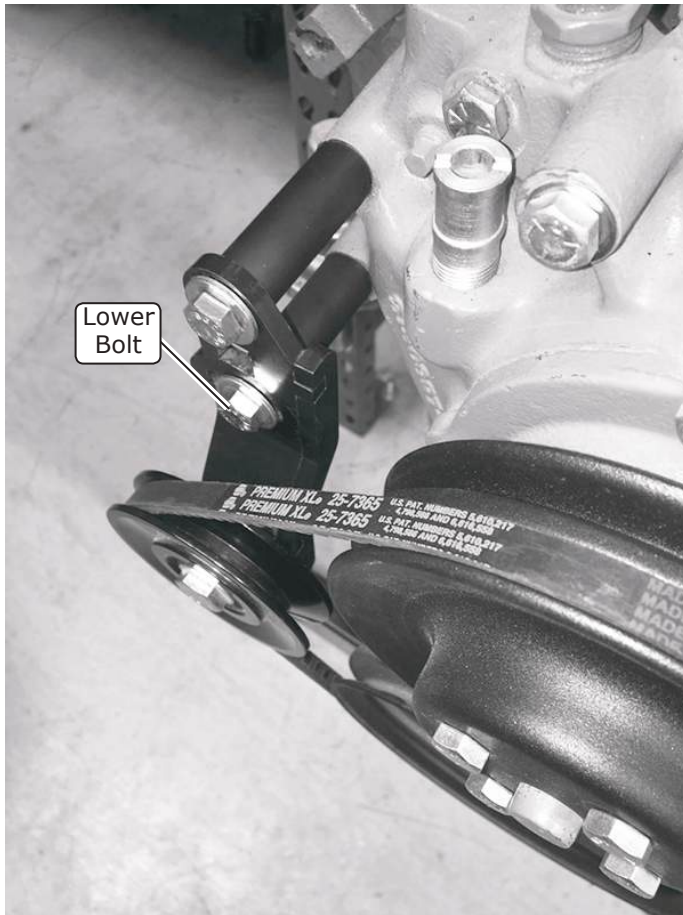

Photo 4

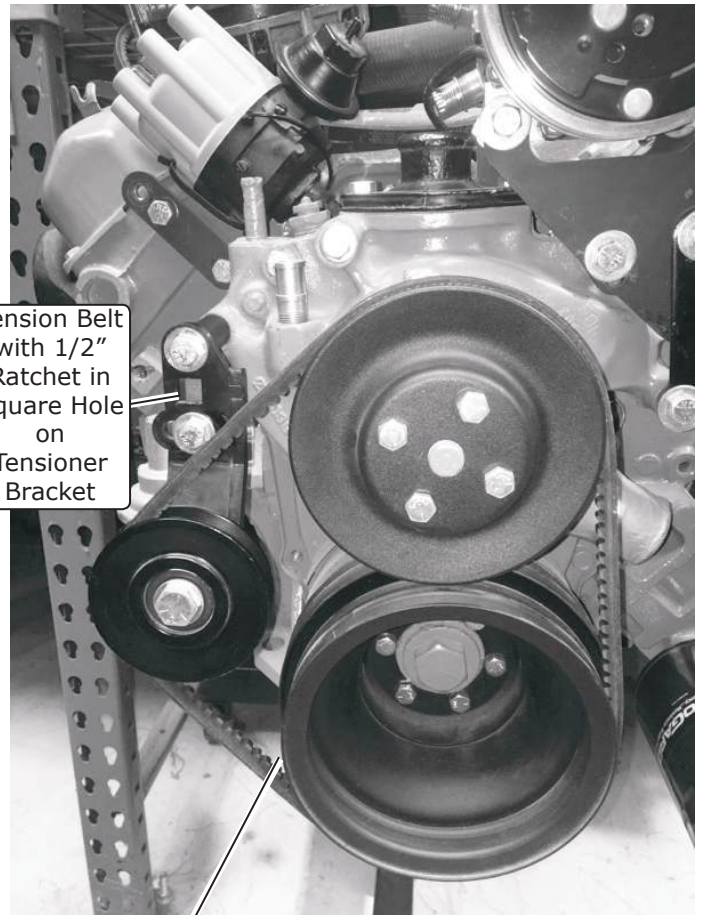

Photo 5

Belt Installs onto Front Crankshaft Pulley Groove



www.vintageair.com

For Use with Vintage Air Bracket Kit #161002

1. Assemble the supplied tensioner pulley and tensioner bracket using the shoulder bolt, the .250" L spacer, and the 7/16-20 locknut as shown in Photo 1, below. Ensure the spacer is between the bracket and the pulley, and tighten the assembly.
2. Insert (2) 3/8-16 x 5" hex bolts with 3/8" washers through the tensioner bracket as shown in Photo 2, below. Install (2) .750" L spacers onto the bolts (See Photo 2, below).
3. Insert the (2) 3/8-16 x 5" hex bolts through the alternator bracket and into the water pump as shown in Photo 3, below. **NOTE: Tighten only the upper bolt at this time.**

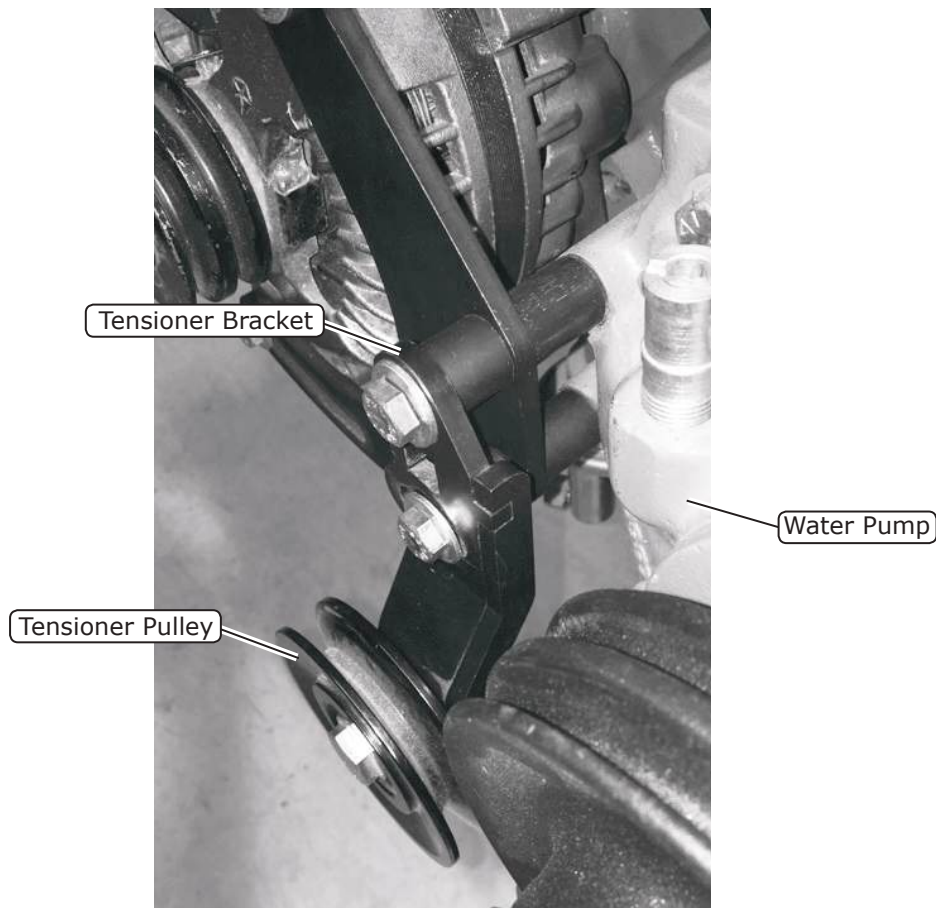
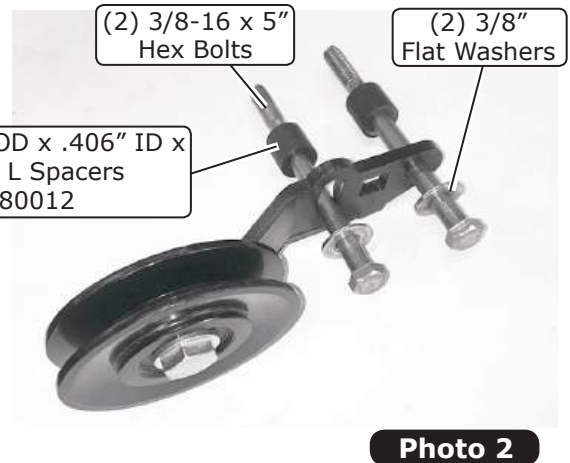
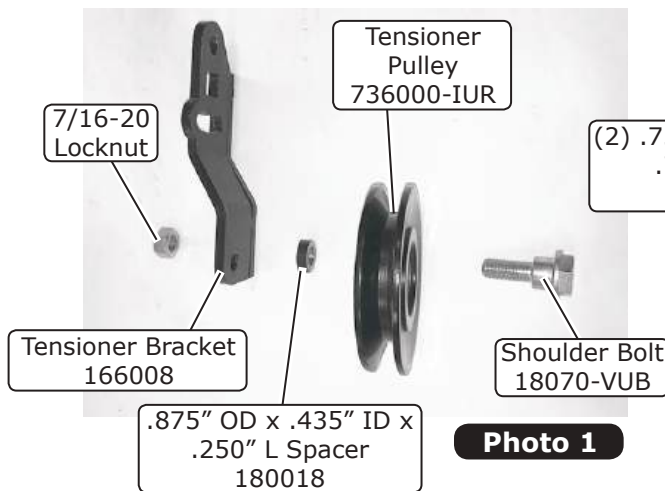



www.vintageair.com

For Use with Vintage Air Bracket Kit #161002 (Cont.)

4. Reinstall the belt onto the tensioner pulley, the crankshaft and the water pump. **NOTE: The belt installs onto the front crankshaft and water pump pulley grooves (See Photo 5, below).**
5. Tension the belt using a 1/2" ratchet handle in the square hole on the bracket (See Photo 5, below). With the belt at the proper tension, tighten the lower bolt on the tensioner bracket (See Photo 4, below).
6. Tighten any remaining bolts, and reinstall the fan and fan clutch (if removed).

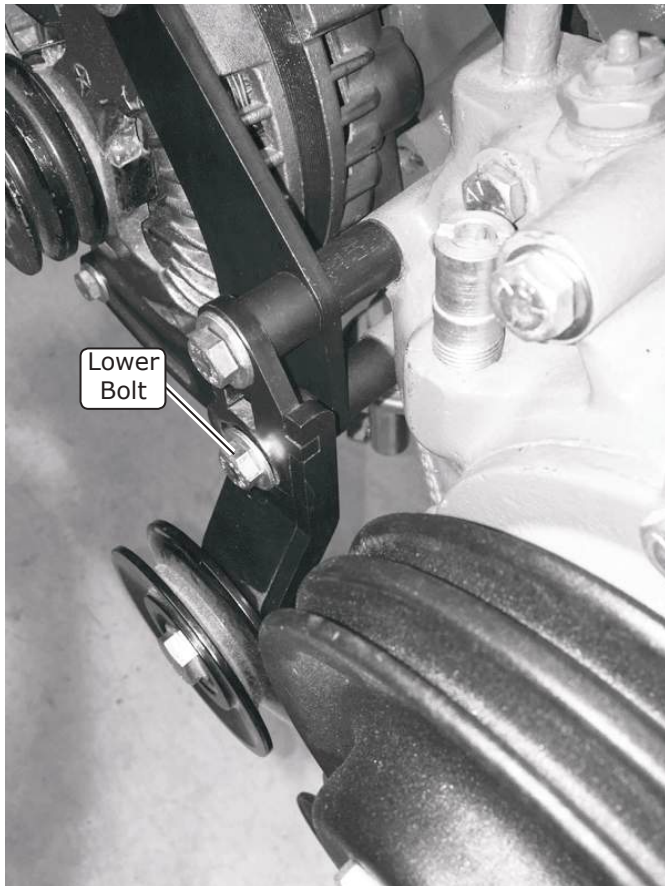

Photo 4

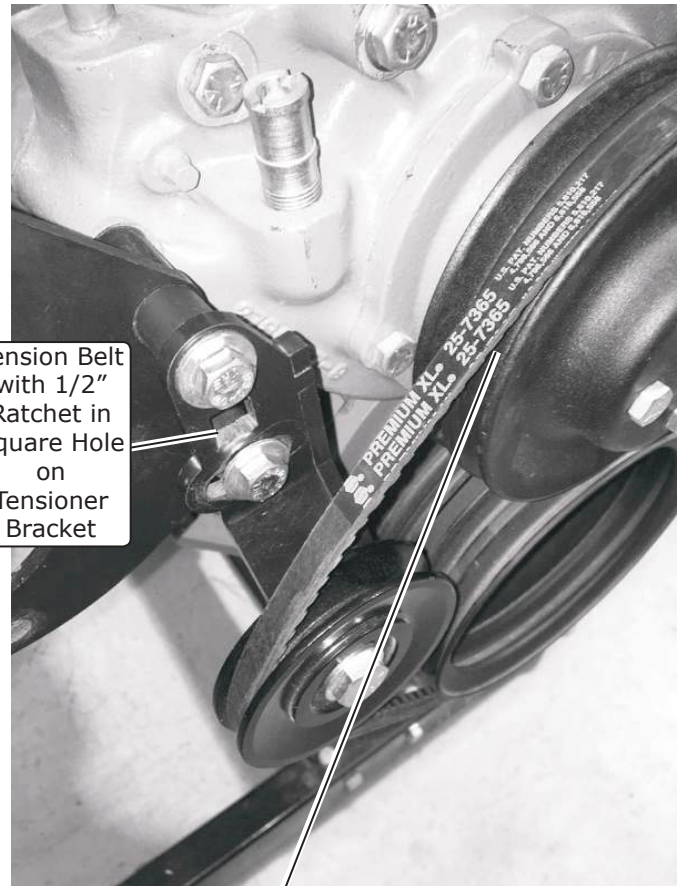

Photo 5



www.vintageair.com

Packing List: Water Pump Tensioner Kit (166009)

No.	Qty.	Part No.	Description
1.	1	166008	Bracket, Water Pump Tensioner
2.	1	191041	Hardware Kit

Checked By: _____
Packed By: _____
Date: _____

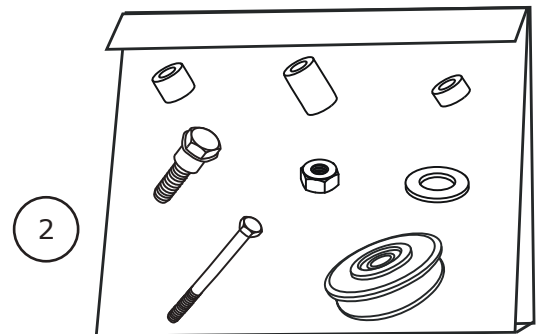
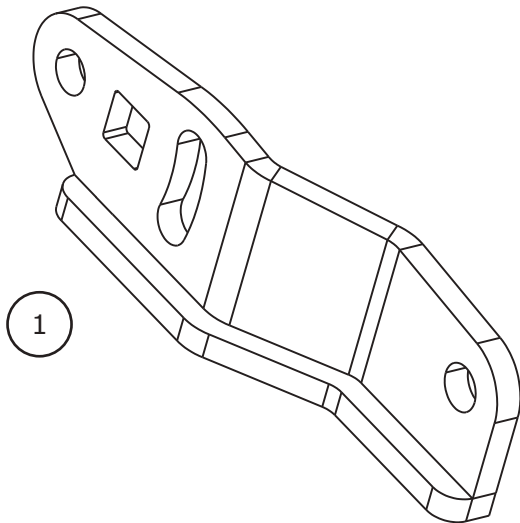

**NOTE: Images may not depict actual parts and quantities.
Refer to packing list for actual parts and quantities.**