

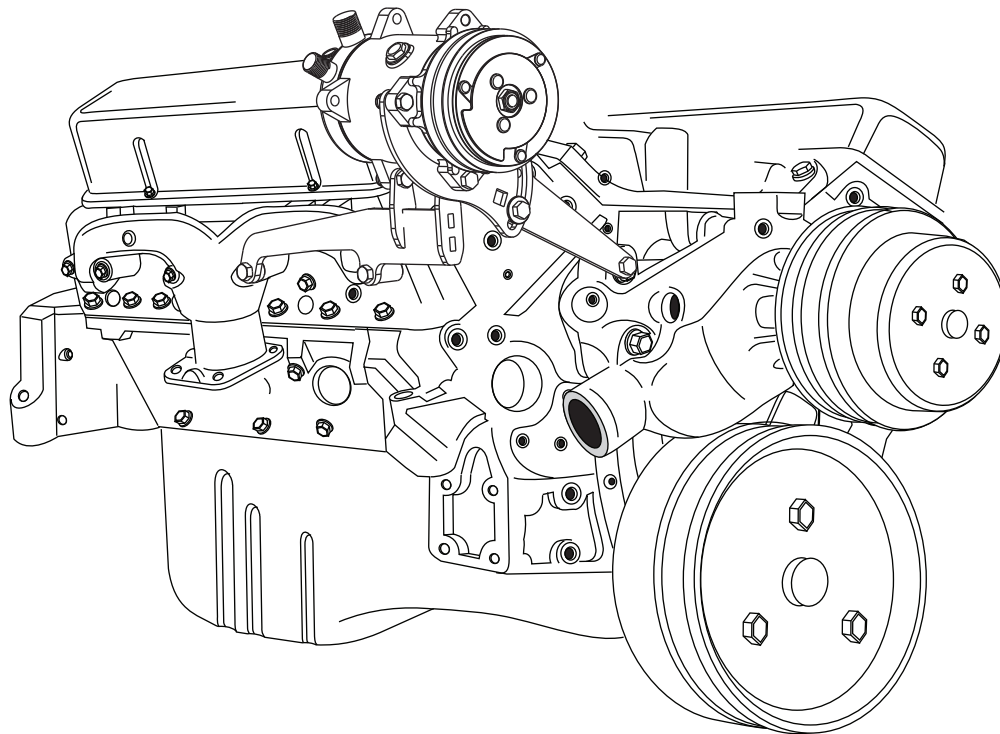

Small Block Chevy

Long Pump/Passenger Side
Compressor Bracket Kit
(15311-VCB)



18865 Goll St. San Antonio, TX 78266
Phone: 800-862-6658
Sales: sales@vintageair.com
Tech Support: tech@vintageair.com
www.vintageair.com



www.vintageair.com

Table of Contents

Cover..... 1

Table of Contents..... 2

Packing List/Parts Disclaimer..... 3

Installation Preparation..... 4

Rear Mounting Bracket Installation..... 5

Front and Compressor Mounting Bracket Installation, Compressor Installation..... 6

Belt Routing, Compressor Warning..... 7

Packing List..... 8



www.vintageair.com

Packing List: Compressor Bracket Kit (15311-VCB)

No.	Qty.	Part No.	Description
1.	1	146003-SCR	Bracket, Front Mounting
2.	1	146005-SCA	Bracket, Rear Mounting
3.	1	146006-SCR	Bracket, Compressor Mounting
4.	1	191311-HCA	Hardware Kit

**** Before beginning installation, open all packages and check contents of shipment. Please report any shortages directly to Vintage Air within 15 days. After 15 days, Vintage Air will not be responsible for missing or damaged items.**

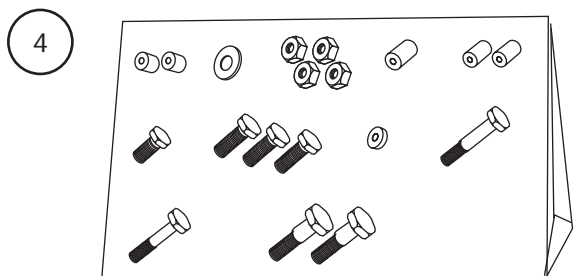
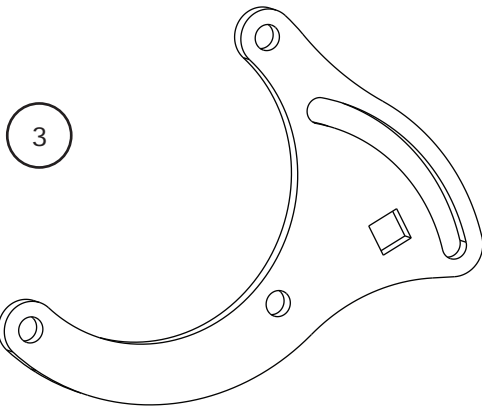
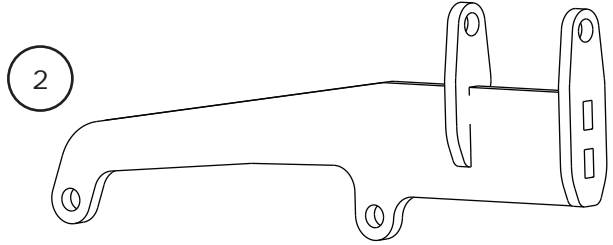
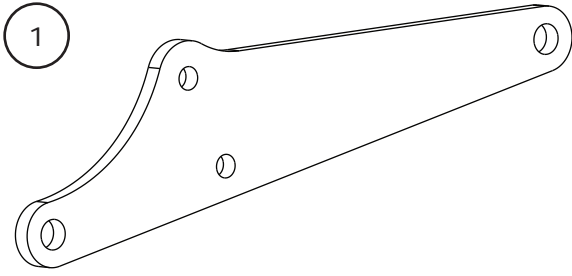

NOTE: Images may not depict actual parts and quantities. Refer to packing list for actual parts and quantities.

Installation Preparation

1. Remove the top water pump mounting bolt on the passenger side (discard). (See Figure 1, below).
2. Remove the 1st and 3rd manifold bolts on the passenger side (discard). (See Figure 1, below).

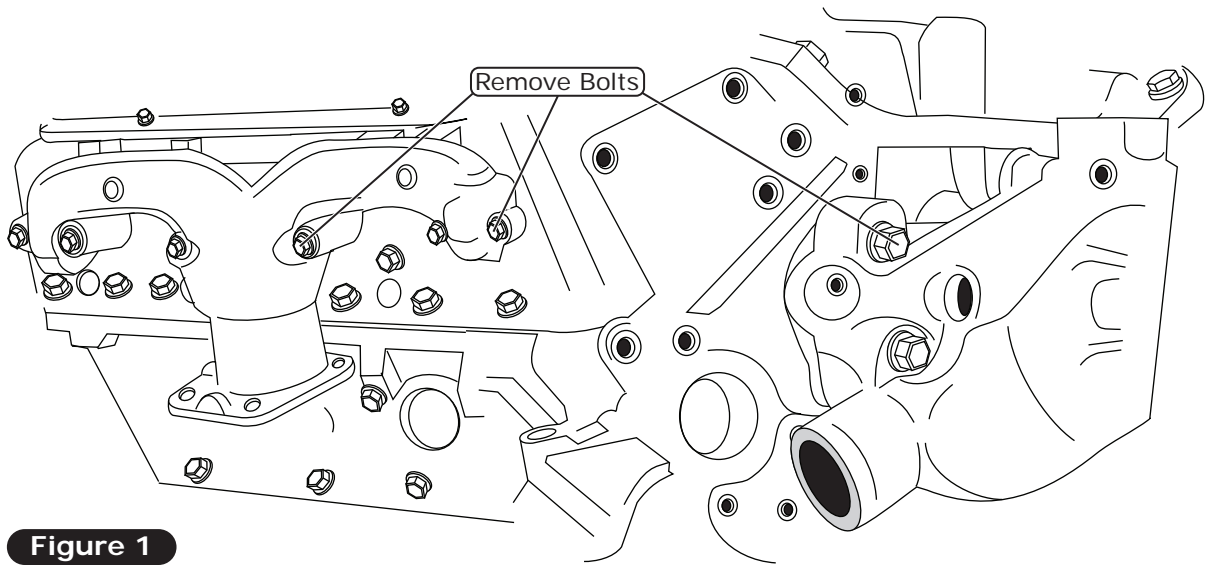

Figure 1



www.vintageair.com

Rear Mounting Bracket Installation

1. Install the compressor rear mounting bracket onto the manifold using (2) 3/8-16 x 3 1/4" hex bolts, a .250" length spacer and a 1.0625" length spacer (See Figure 1, below). **NOTE: Assemble all brackets loosely to engine, before tightening bolts. This will ensure proper alignment of all brackets.**

NOTE: Exhaust Spacers

Ram Horn Manifolds use a .250" length spacer at the rear of the rear mounting bracket and a 1.0625" length spacer at the front of bracket as shown below.

Drop-Type Manifolds use (2) 1.0625" length spacers

Headers use (2) 2.250" length spacers

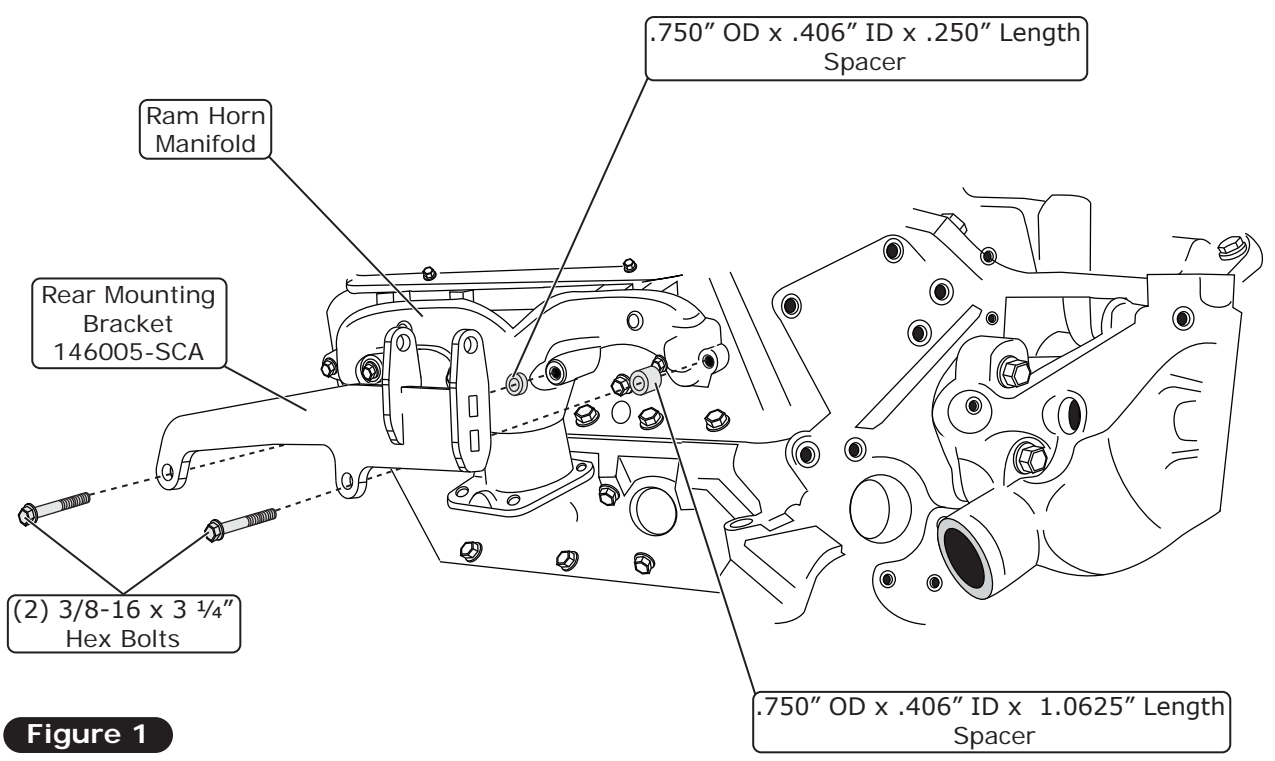

Figure 1

Front and Compressor Mounting Bracket Installation

1. Install the front mounting bracket onto the water pump using a 3/8-16 x 3 3/4" hex bolt and a 1.250" length spacer (See Figure 1, below).
2. Install the compressor mounting bracket onto the front mounting bracket using a 3/8" flat washer and 3/8-16 x 1" hex bolt (See Figure 1, below).

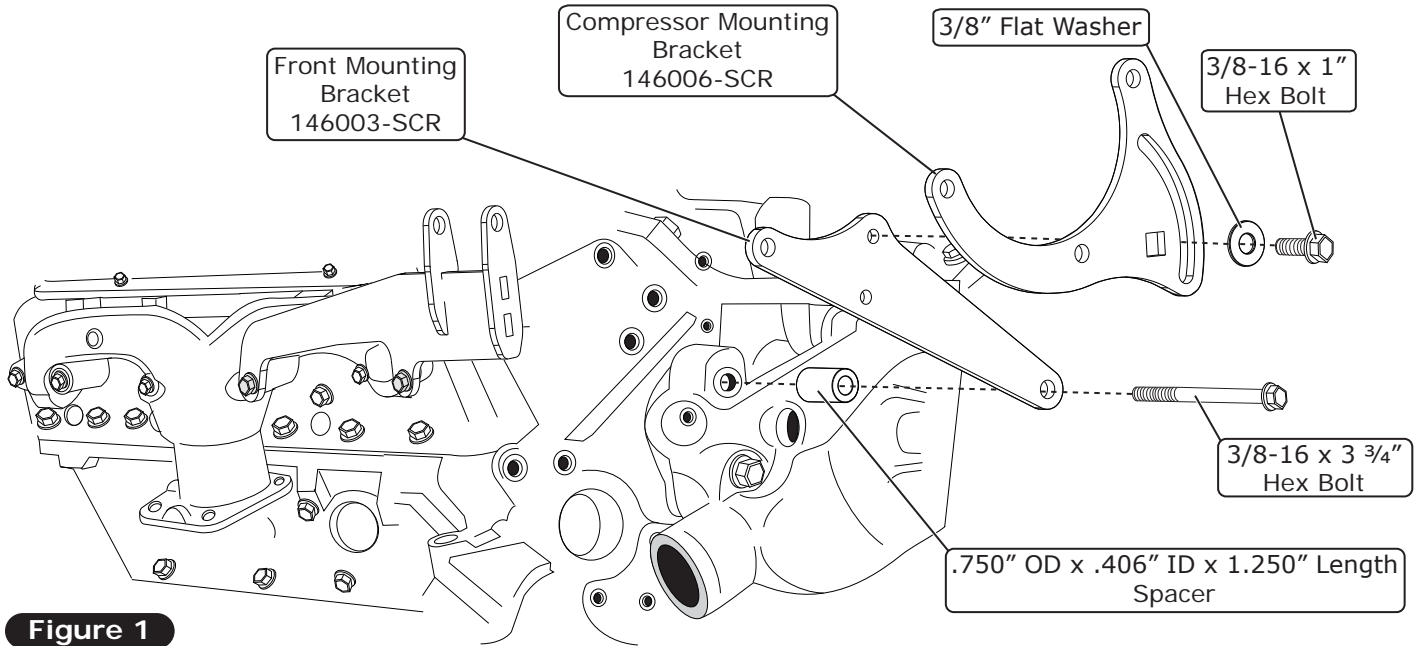

Figure 1

Compressor Installation

1. Install the compressor onto the rear and compressor mounting brackets using (3) 3/8-16 x 1 1/4" hex bolts, a 3/8-16 x 2" hex bolt and (4) 3/8" locknuts (See Figure 1, below).

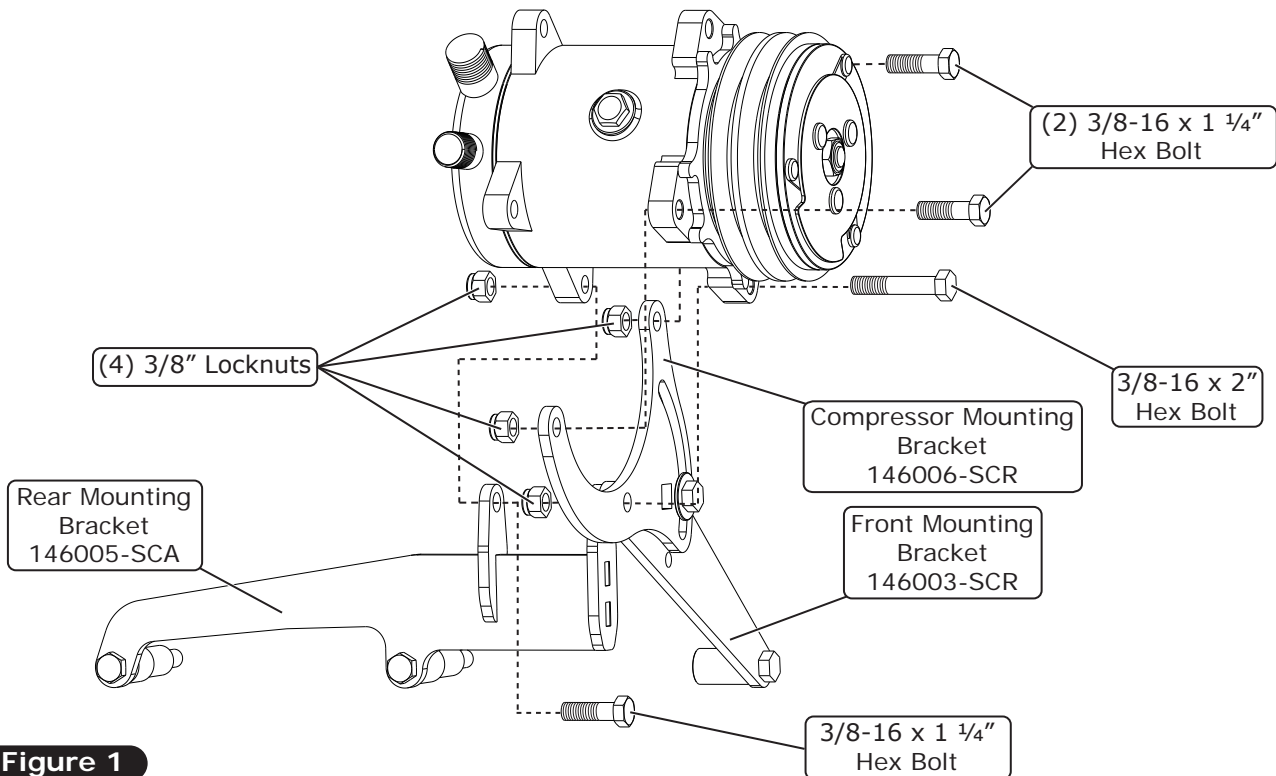
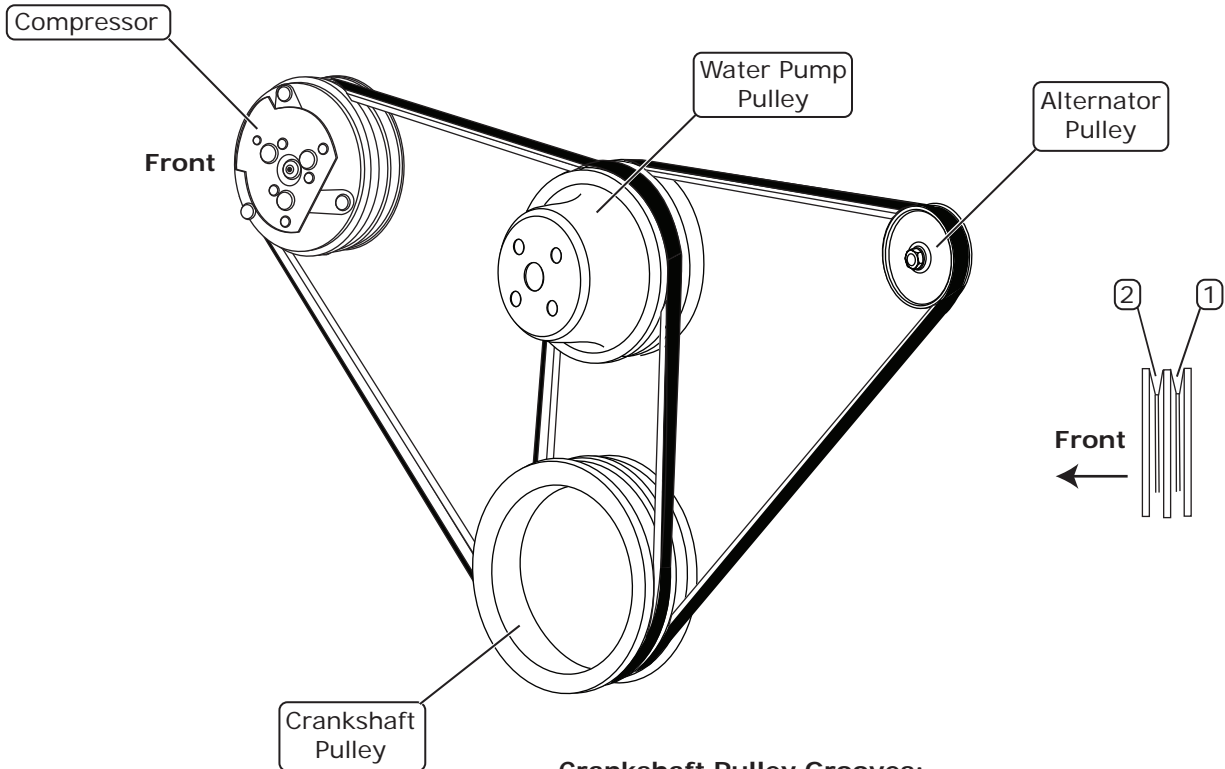

Figure 1

Belt Routing

1. Route the belt as shown below. Vintage Air recommends using only Dayco, Gates or Goodyear brand reinforced V-belts with this compressor bracket kit. Compressor belt length of 60 to 61 inches is recommended. **NOTE: This can vary with diameter of your waterpump and crankshaft pulleys.**



Crankshaft Pulley Grooves:

1. Crankshaft, Water Pump & Alternator
2. Crankshaft, Water Pump & Compressor (Front Groove)

Compressor Warnings

NOTE: Failure to follow these procedures may void all warranties.

1. With compressor kit installed, and belt tightened, check angle of oil plug on compressor. As shown below, oil plug must not exceed 90° beyond vertical centerline.
2. Do not connect compressor clutch wire until system is being charged with refrigerant. Running compressor without refrigerant charge may result in compressor failure.

IMPORTANT NOTICE:

- Do not connect compressor clutch wire until system is being charged with refrigerant. Since an A/C system relies on refrigerant to circulate lubricant, running the compressor without refrigerant may destroy the compressor and void the warranty.
- Proper compressor orientation is important. Sanden compressors may be rotated from vertical (oil fill plug at top) up to 90° in either direction (See illustration).

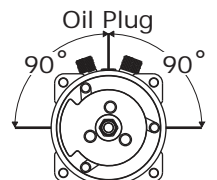



www.vintageair.com

Packing List: Compressor Bracket Kit (15311-VCB)

No.	Qty.	Part No.	Description
1.	1	146003-SCR	Bracket, Front Mounting
2.	1	146005-SCA	Bracket, Rear Mounting
3.	1	146006-SCR	Bracket, Compressor Mounting
4.	1	191311-HCA	Hardware Kit

Checked By: _____
 Packed By: _____
 Date: _____

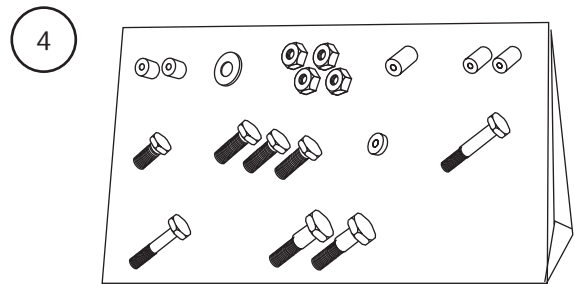
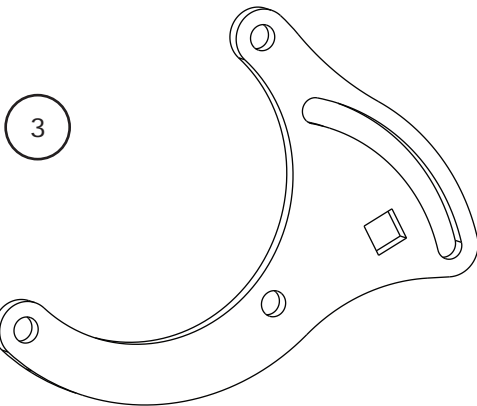
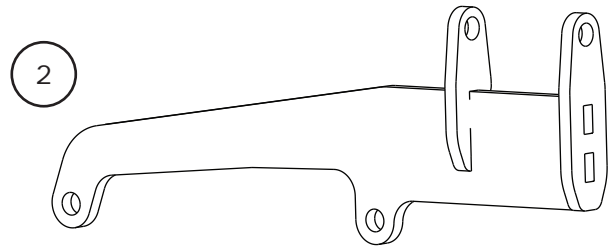
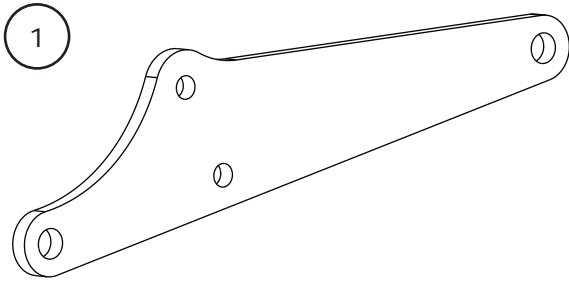

**NOTE: Images may not depict actual parts and quantities.
 Refer to packing list for actual parts and quantities.**