

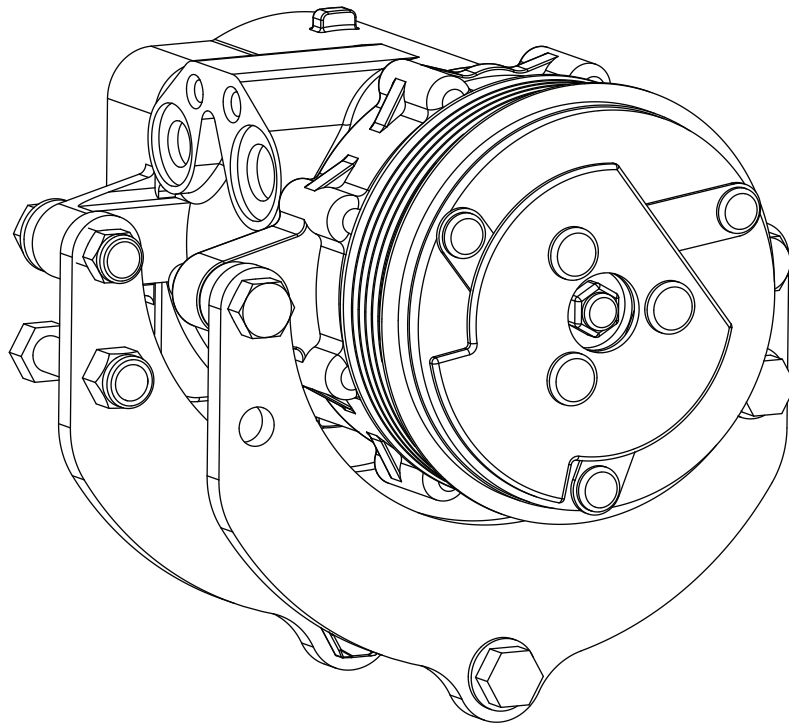

# 1988-95 GM 454 to 7B10

Adapter Bracket Kit  
(151588)



18865 Goll St. San Antonio, TX 78266  
Phone: 800-862-6658  
Sales: [sales@vintageair.com](mailto:sales@vintageair.com)  
Tech Support: [tech@vintageair.com](mailto:tech@vintageair.com)  
[www.vintageair.com](http://www.vintageair.com)



www.vintageair.com

# Table of Contents

Cover..... 1

Table of Contents..... 2

Packing List/Parts Disclaimer..... 3

Adapter Bracket Installation..... 4

Adapter Bracket Installation (Cont.)..... 5

Adapter Bracket Installation (Final)..... 6

Belt Routing..... 7

Important Compressor Information..... 8

Packing List..... 9

## Additional Info: Please Read Before Beginning

- This compressor adapter kit is not intended to be used with the OEM A/C system, and is only recommended to work with Vintage Air systems.
- Before disconnecting any A/C compressor lines, be sure the system is properly evacuated.
- The compressor grounds through the bracket and into the engine, therefore, it is important to have a good ground connection. A separate ground wire may also be run to ensure ground continuity.
- Vintage Air recommends using only Dayco, Gates or Goodyear brand reinforced belts with this compressor bracket kit. Belt lengths may vary depending on the accessories present and the diameter of the water pump, crankshaft, alternator and power steering pulleys. Measure your setup to verify the belt lengths.
- This bracket requires a 7B10 serpentine belt compressor (Vintage Air part number 046768-MTR (standard finish), 046769-MTQ (polished finish) or 046770 (chrome finish)).



www.vintageair.com

# Packing List: Bracket Kit (151588)

No.	Qty.	Part No.	Description
1.	2	151587	Bracket, Adapter, .250" Thick
2.	1	191188	Hardware Kit

**\*\* Before beginning installation, open all packages and check contents of shipment. Please report any shortages directly to Vintage Air within 15 days. After 15 days, Vintage Air will not be responsible for missing or damaged items.**

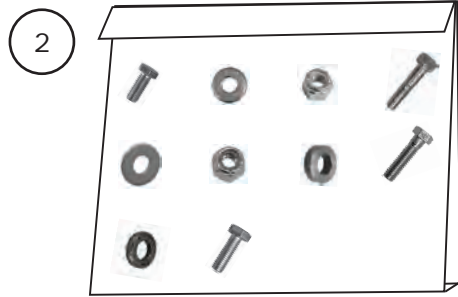

**NOTE: Images may not depict actual parts and quantities. Refer to packing list for actual parts and quantities.**

**NOTE:** Before tightening bolts, assemble all brackets loosely to engine. This will ensure proper alignment of all brackets.

www.vintageair.com

## Adapter Bracket Installation

1. Install one of the adapter brackets onto the front of the OEM bracket assembly using (2) 3/8-16 x 1" hex bolts, (2) 5/16" flat washers and (2) 3/8-16 locknuts (See Photos 1 and 2, below).
2. Install the second adapter bracket onto the inside-rear of the OEM bracket assembly using (2) 10mm x 25mm hex bolts and (2) .750" OD x .406" ID x .150" length steel spacers (See Photo 3, below). Leave loose.
3. Into the rear of the remaining hole, install a 3/8-16 x 1 3/4" hex bolt, a 5/16" flat washer, a .750" OD x .406" ID x .150" length steel spacer and a 3/8-16 locknut (See Photo 4, below).

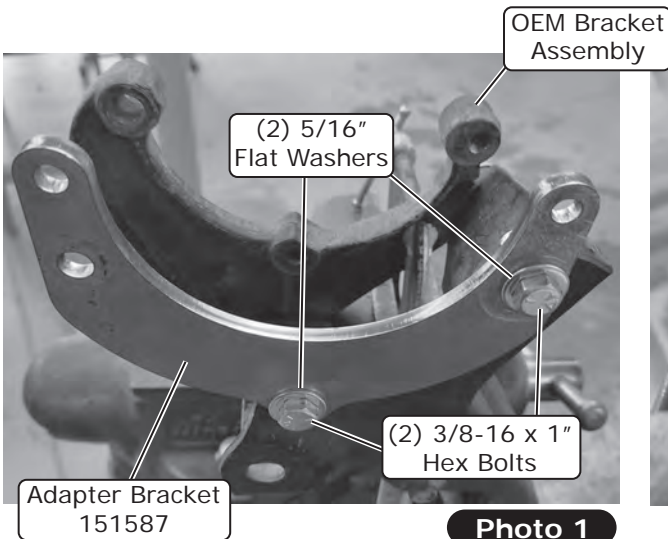

**Photo 1**

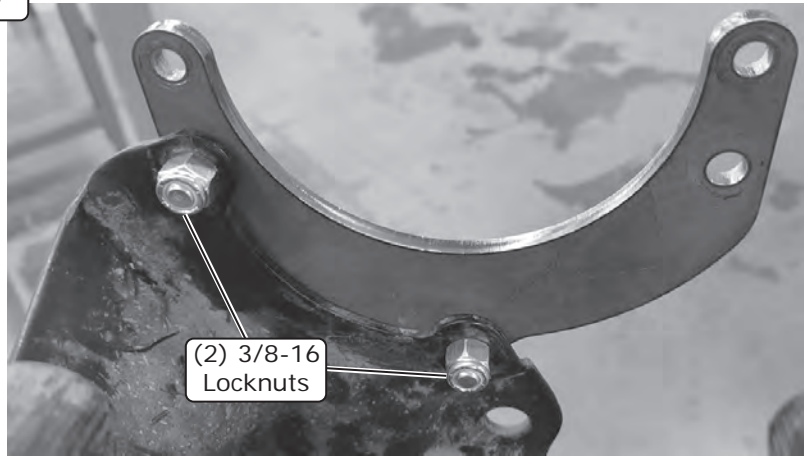

**Photo 2**

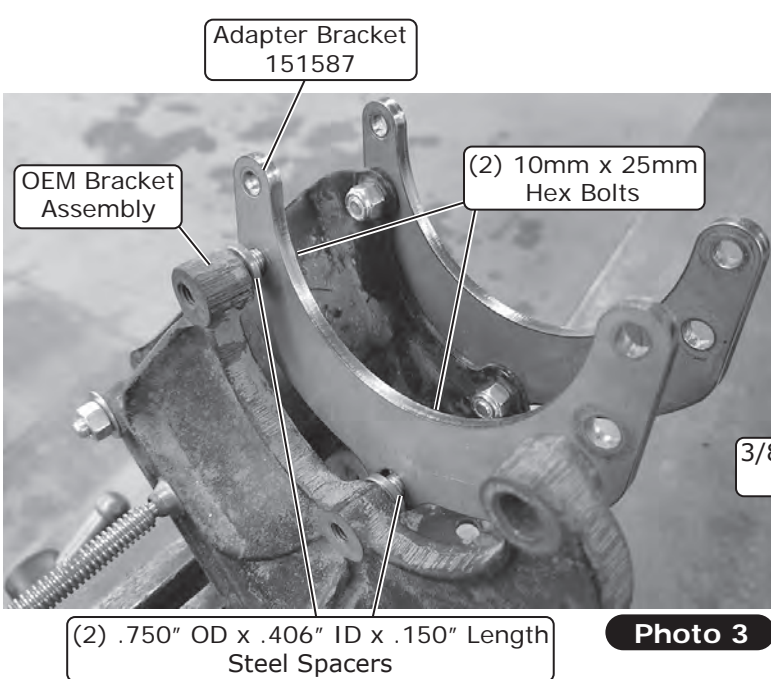

**Photo 3**

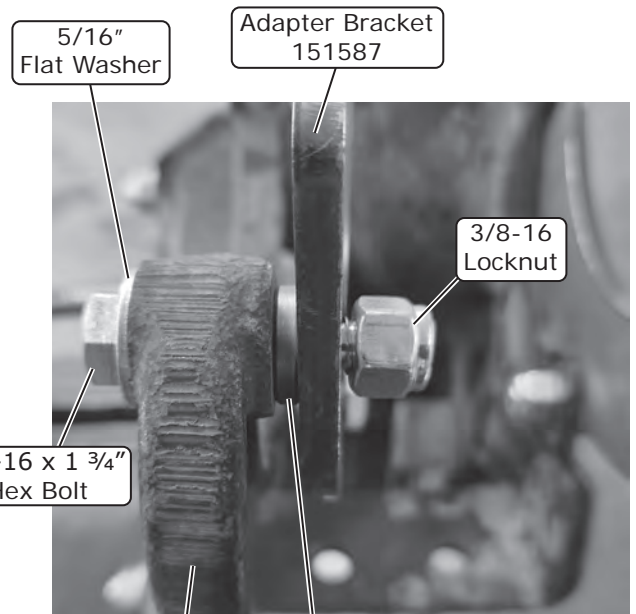
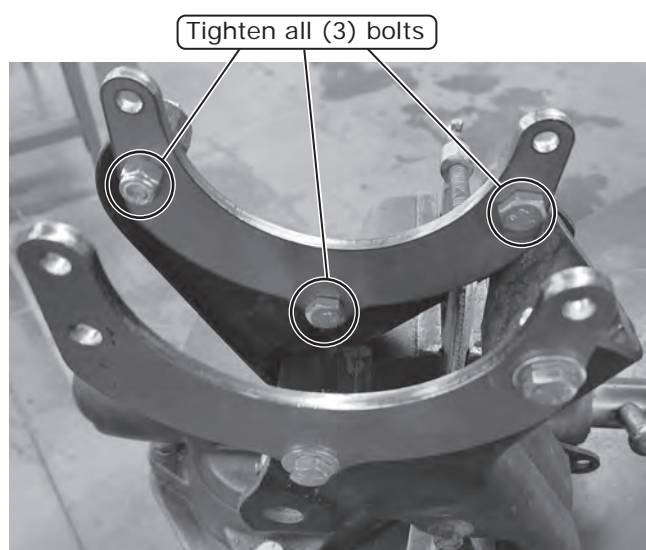

**Photo 4**

**NOTE:** Before tightening bolts, assemble all brackets loosely to engine. This will ensure proper alignment of all brackets.

## Adapter Bracket Installation (Cont.)

4. Tighten all (3) bolts (See Photo 5, below).
5. Place the compressor into the cradle (See Photo 6, below).
6. On the rear compressor ears, install (2) 5/16-18 x 1 1/2" hex bolts and (2) 5/16-18 locknuts (See Photo 7, below).
7. On the front compressor ears, install (2) 5/16-18 x 1 1/2" hex bolts, (2) .750" OD x .406" ID x .250" length steel spacers, (2) 1/4" USS flat washers and (2) 5/16-18 locknuts as shown in Photo 8, below. Tighten hardware.



**Photo 5**

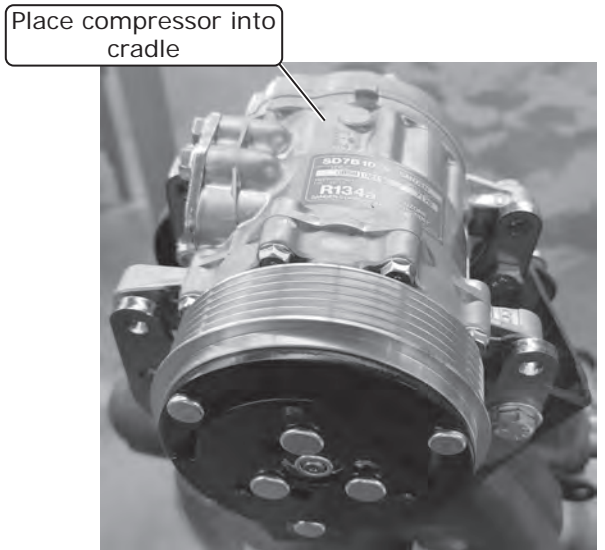

**Photo 6**

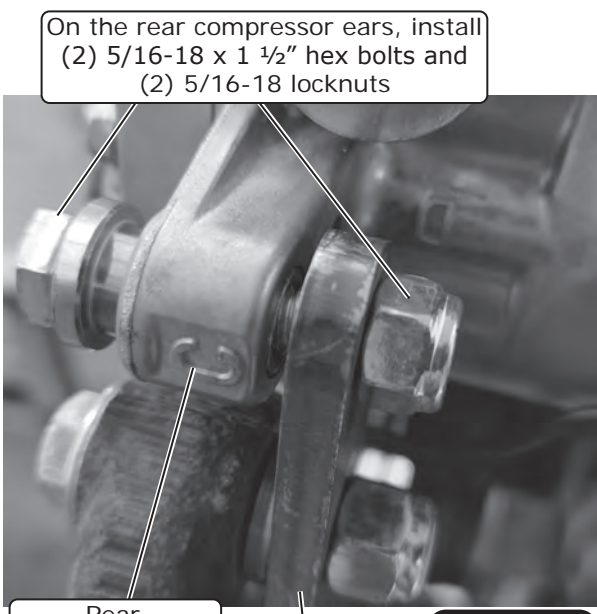

**Photo 7**

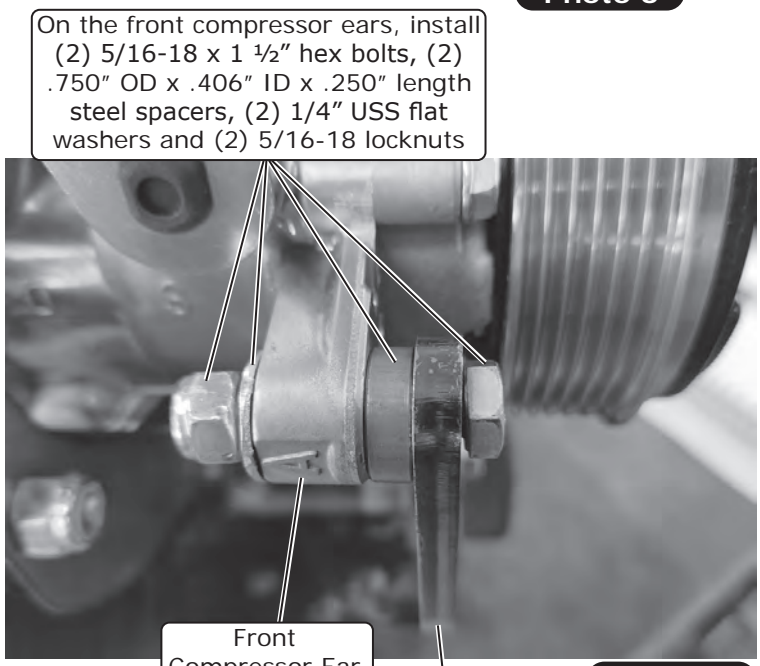

**Photo 8**

Rear Compressor Ear

Adapter Bracket 151587

Front Compressor Ear

Adapter Bracket 151587

**NOTE:** Before tightening bolts, assemble all brackets loosely to engine. This will ensure proper alignment of all brackets.

## Adapter Bracket Installation (Final)

8. Slowly tighten rear bolts, allowing the bushings to take up any slack between the bracket and the compressor ears (See Photo 9, below).
9. Ensure all bolts are tightened at this time (See Photo 10, below).
10. The finished install can be seen in Photo 11, below.

Slowly tighten rear bolts, allowing the bushings to take up any slack between the bracket and the compressor ears.



**Photo 9**

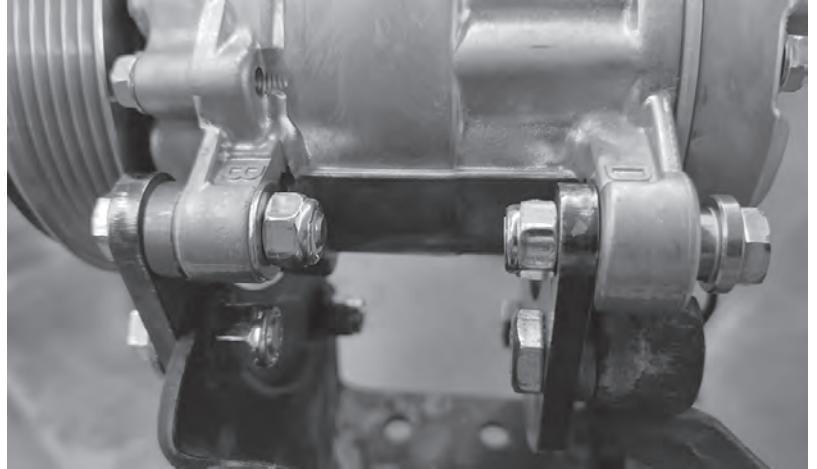

Ensure all bolts are tightened at this time

**Photo 10**



Final Installation

**Photo 11**

## Belt Routing

1. Route belt as shown below. Vintage Air recommends using only Dayco, Gates or Goodyear brand reinforced V-belts with this bracket kit.

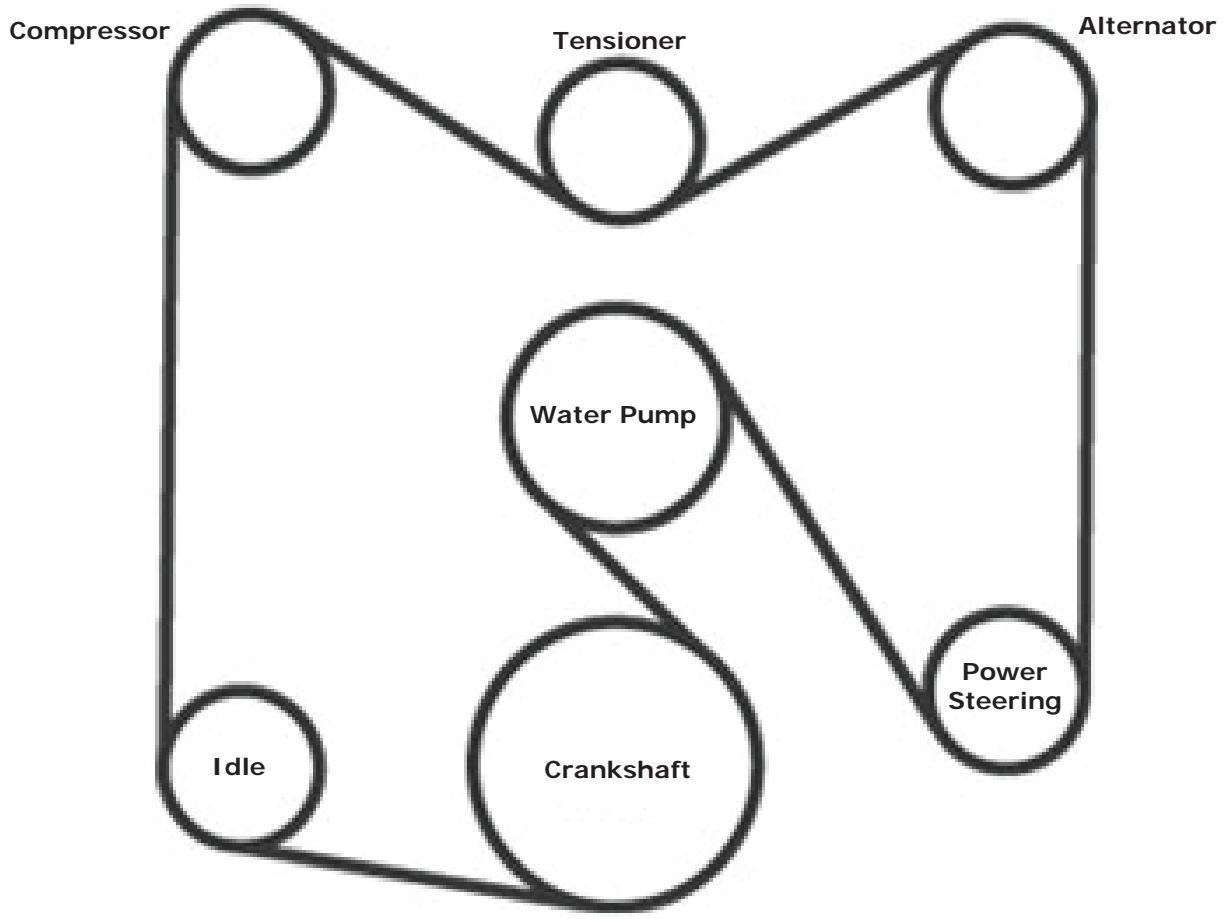

# Important Compressor Information

## Sanden 508 Style Compressors

**NOTE:** Failure to follow these procedures may void all warranties.

- Do not connect compressor clutch wire until system is being charged with refrigerant. Since an A/C system relies on refrigerant to circulate lubricant, running the compressor without refrigerant may destroy the compressor and void the warranty.
- Proper compressor orientation is important. Sanden compressors may be rotated from vertical (oil fill plug at top) up to 90° in either direction (See illustration, below).

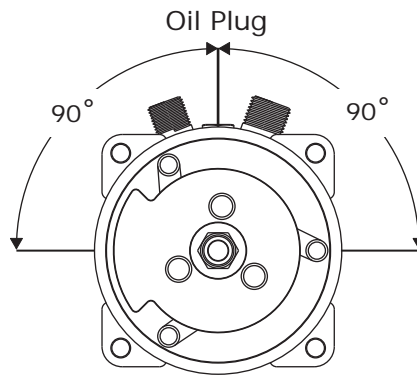

## Sanden 7B10 Style Compressors

**NOTE:** Failure to follow these procedures may void all warranties.

- Do not connect compressor clutch wire until system is being charged with refrigerant. Since an A/C system relies on refrigerant to circulate lubricant, running the compressor without refrigerant may destroy the compressor and void the warranty.
- These compressors do not have an oil fill plug. Please reference the block fitting mount face for clocking range (See illustration, below).

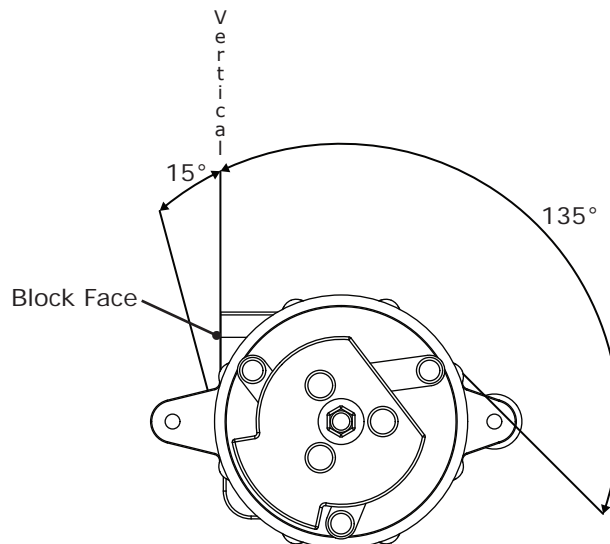







www.vintageair.com

# Packing List: Bracket Kit (151588)

No.	Qty.	Part No.	Description
1.	2	151587	Bracket, Adapter, .250" Thick
2.	1	191188	Hardware Kit

Checked By: \_\_\_\_\_  
Packed By: \_\_\_\_\_  
Date: \_\_\_\_\_

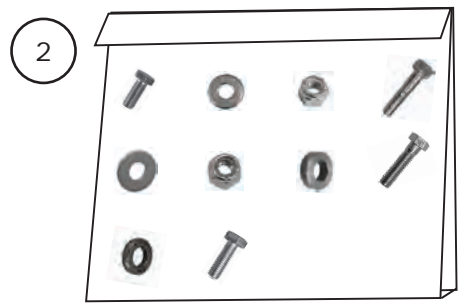

**NOTE: Images may not depict actual parts and quantities.  
Refer to packing list for actual parts and quantities.**