

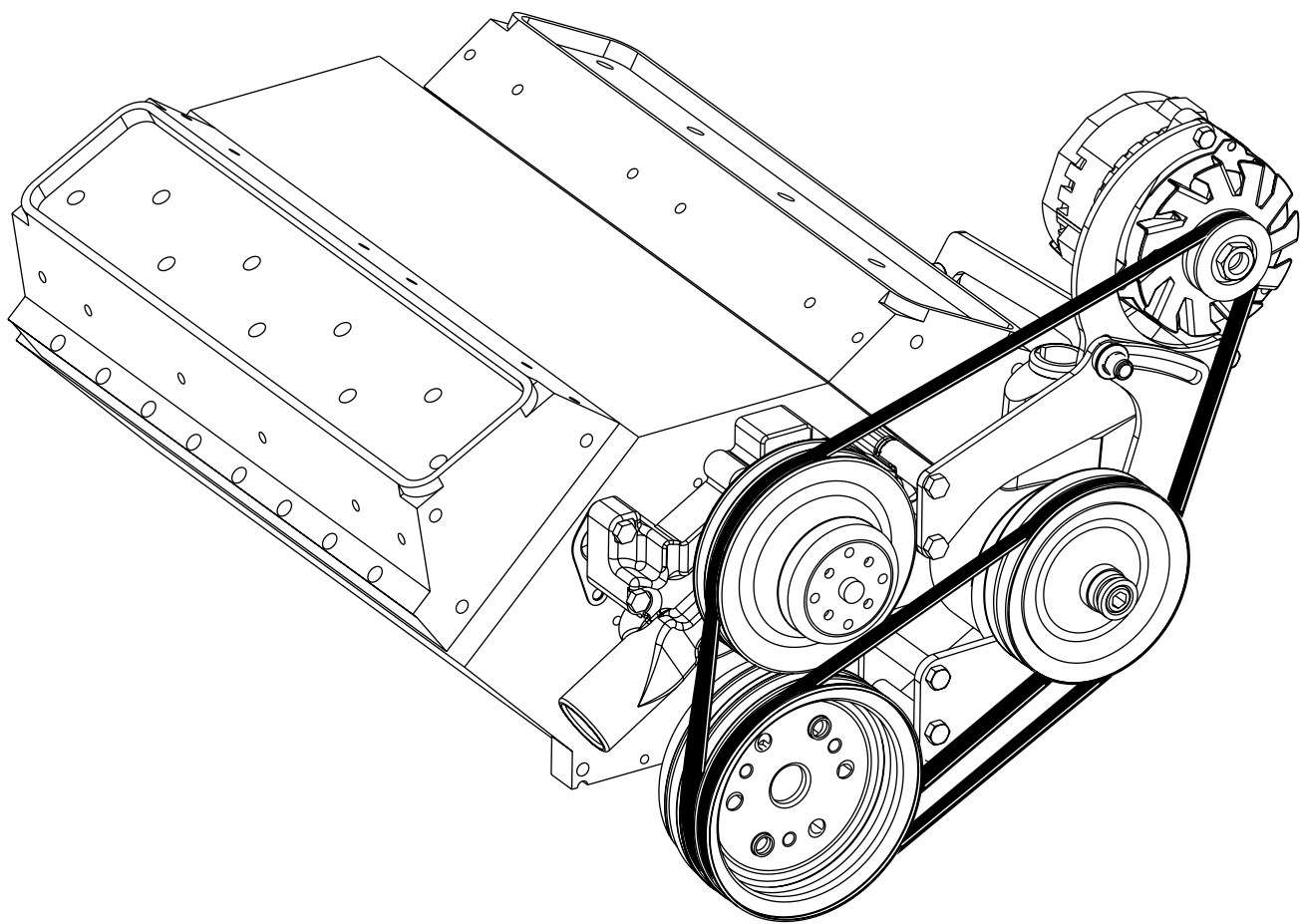

Small Block Chevrolet Short Pump Mid-Mount Alternator/Power Steering Bracket Kit (1964-67 Chevelle) 148000



18865 Goll St. San Antonio, TX 78266
Phone: 800-862-6658
Sales: sales@vintageair.com
Tech Support: tech@vintageair.com
www.vintageair.com



Table of Contents

- 1. Cover**
- 2. Table of Contents**
- 3. Packing List/Parts Disclaimer**
- 4. Dimensional References**
- 5. OEM Bolt Removal & Alternator Side Mounting Bracket Installation**
Figure 1
- 6. Alternator Side Mounting Bracket Installation (Cont.) & Power Steering Pump Adjuster Bracket Installation**
- 7. Alternator Adjuster Bracket Installation & Alternator Front Mounting Bracket Installation**
Figures 2 & 3
- 8. Alternator Assembly Installation & Power Steering Pump Mounting Bracket Installation**
Figures 4 & 5
- 9. Power Steering Pump Assembly Installation**
Figures 6 & 7
- 10. Power Steering Pump Pulley Installation & Belt Routing**
Figures 8 & 9
- 11. Packing List**



Packing List: Bracket Kit (148000)

No.	Qty.	Part No.	Description
1.	2	146416	Power Steering Pump Mounting Bracket
2.	1	146027	Alternator Front Mounting Bracket
3.	1	14611-SCR	Alternator Adjuster Bracket
4.	1	146026	Alternator Side Mounting Bracket
5.	1	146415	Power Steering Pump Adjuster Bracket
6.	1	191028	Hardware Kit

**** Before beginning installation, open all packages and check contents of shipment. Please report any shortages directly to Vintage Air within 15 days. After 15 days, Vintage Air will not be responsible for missing or damaged items.**

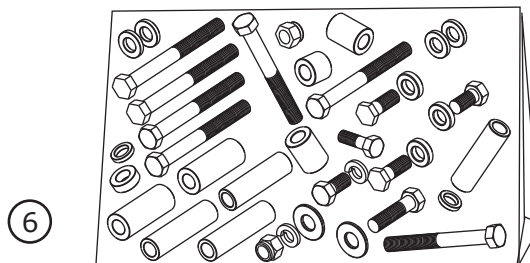
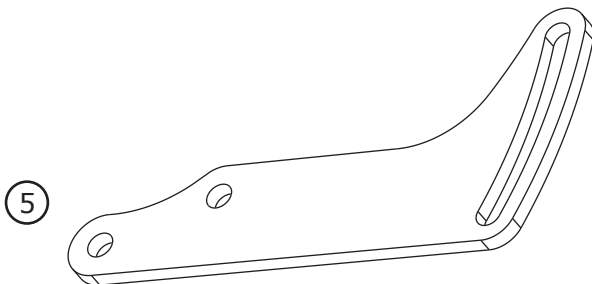
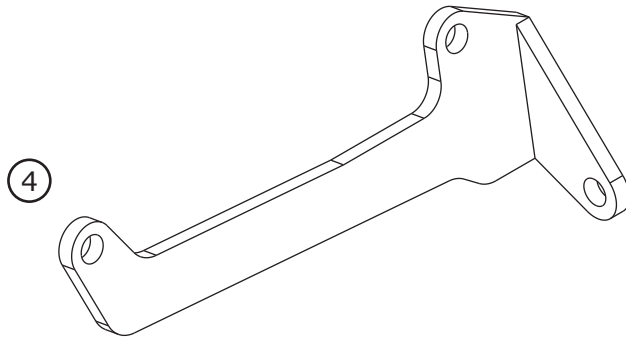
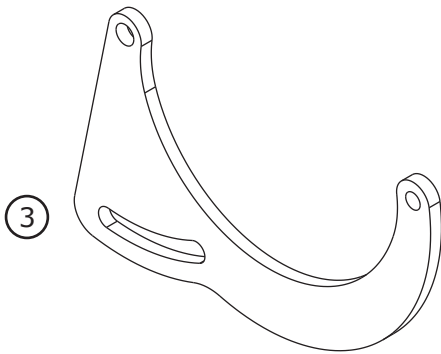
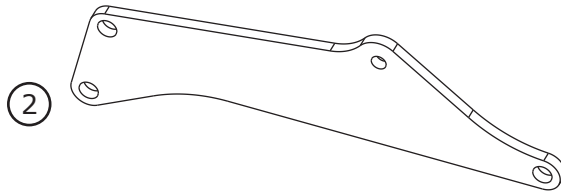
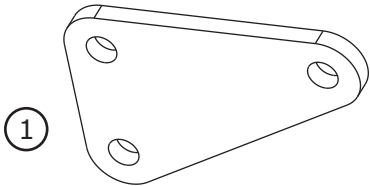

NOTE: Images may not depict actual parts and quantities. Refer to packing list for actual parts and quantities.



Dimensional References

NOTE: Refer to dimensional references provided before installing bracket assembly onto engine. Brackets must be installed to the specified measurements, or the alternator/power steering bracket kit will not function correctly.

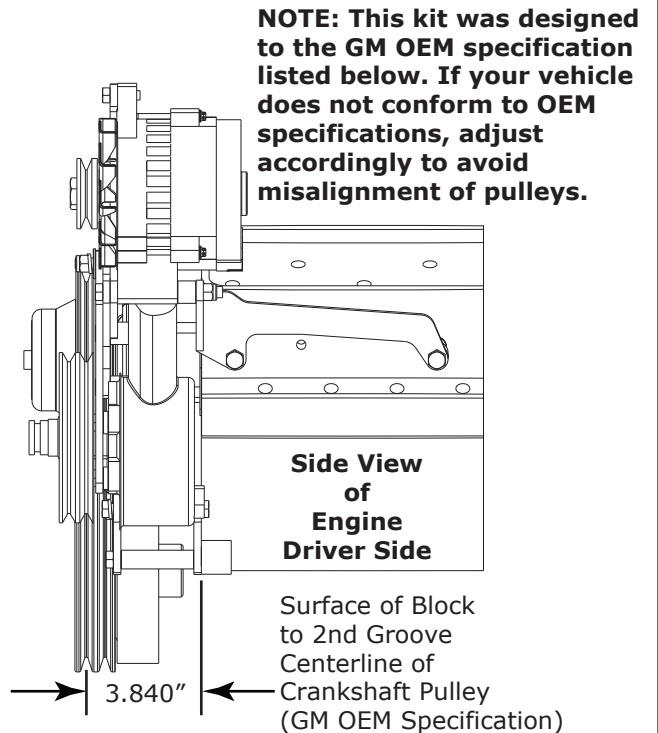
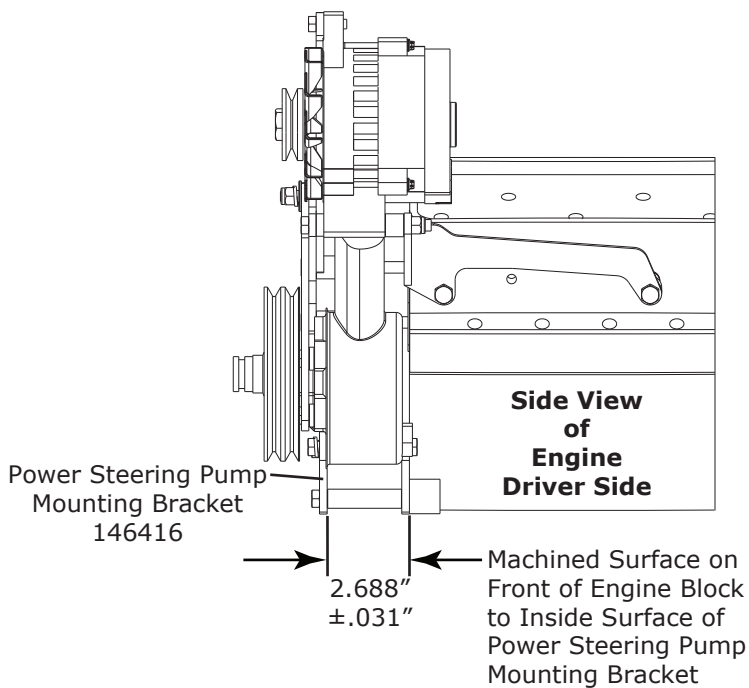
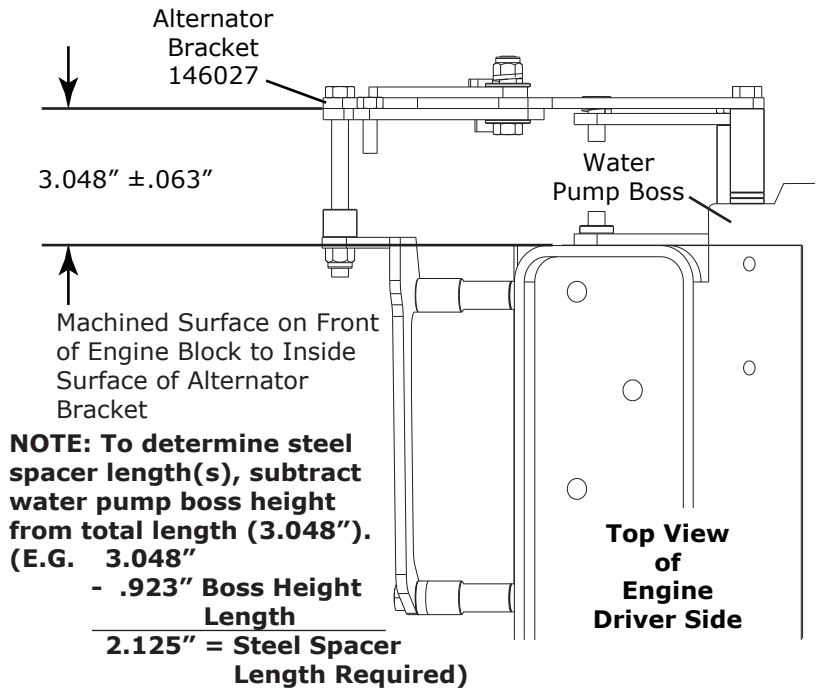
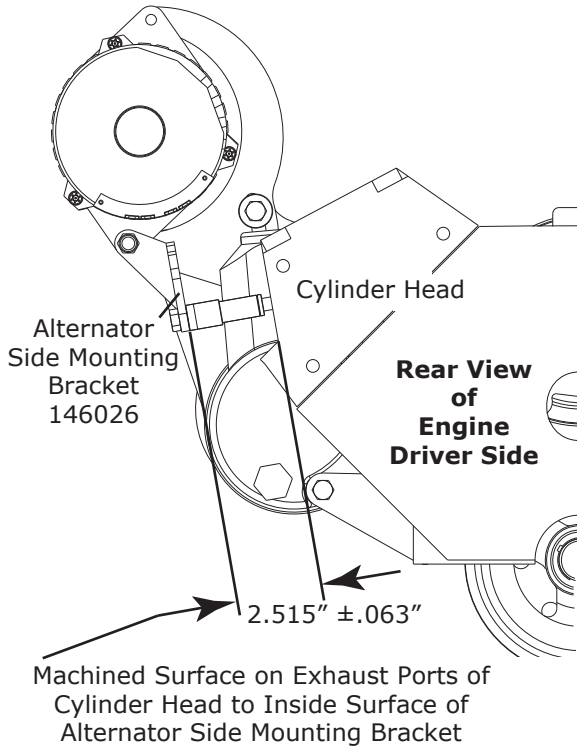



NOTE: Before tightening bolts, assemble all brackets loosely to engine. This will ensure proper alignment of all brackets.

OEM Bolt Removal

1. Remove the driver side water pump mounting bolts (discard) as shown in Figure 1, below.
2. Remove the 1st and 3rd driver side manifold bolts (discard) as shown in Figure 1, below.
3. Remove the lower driver side accessory mounting bolts (discard) as shown in Figure 1, below.

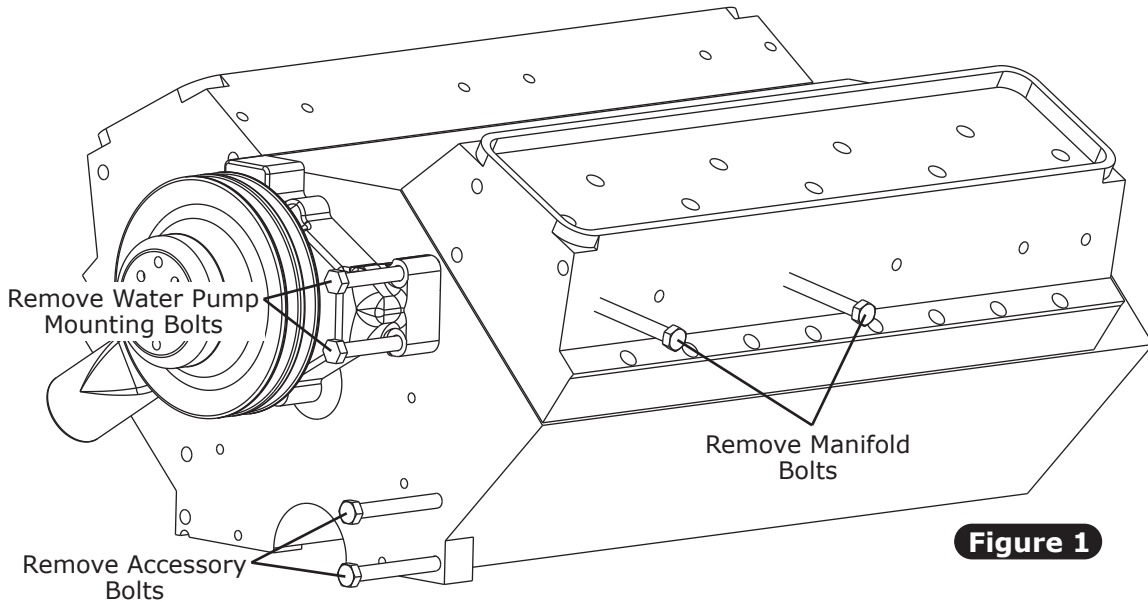

Figure 1

Alternator Side Mounting Bracket Installation

1. Install alternator side mounting bracket onto cylinder head using **ONLY** steel spacers required for applications shown below or on Page 6.

NOTE: For applications not listed below or on Page 6, custom length spacers may be substituted as long as dimensional guidelines are followed.

3/8" Flanged Header

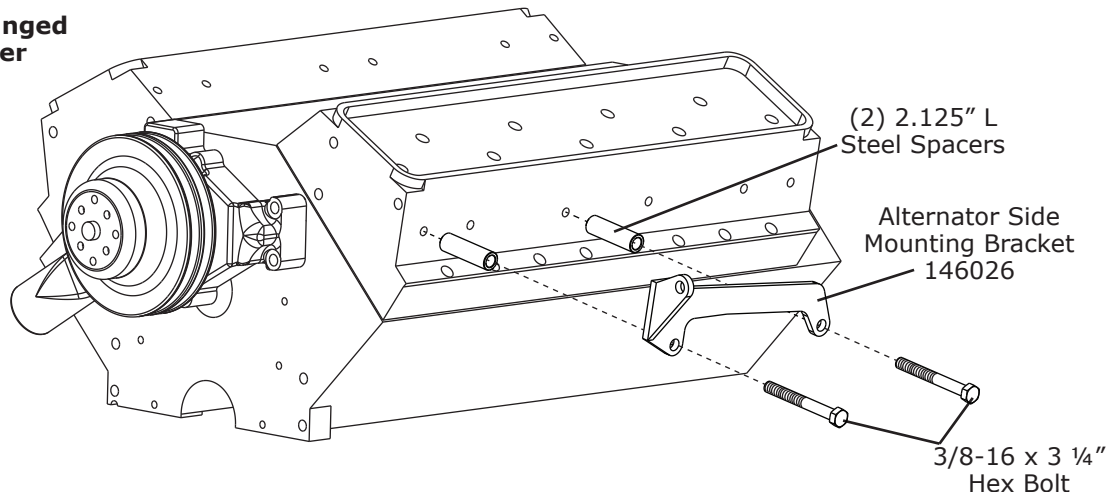

Alternator Side Mounting Bracket Installation (Cont.)

NOTE: To determine steel spacer length(s), subtract 1/4" flanged header height from total length (2.515").
 (E.G. 2.515" Total Length
 - .250" Flanged Header Length
 2.265" = Steel Spacer
 ± .063" Length Required)
 This measurement may vary with gasket thickness.

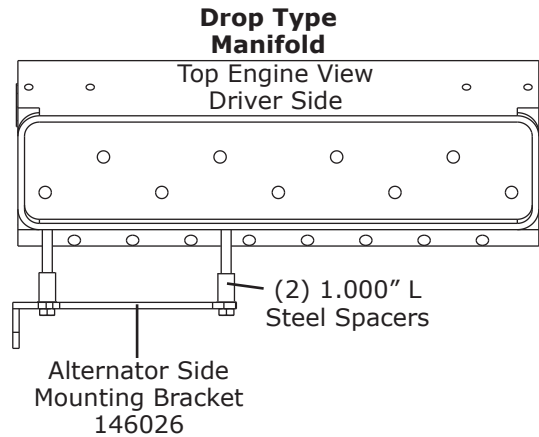
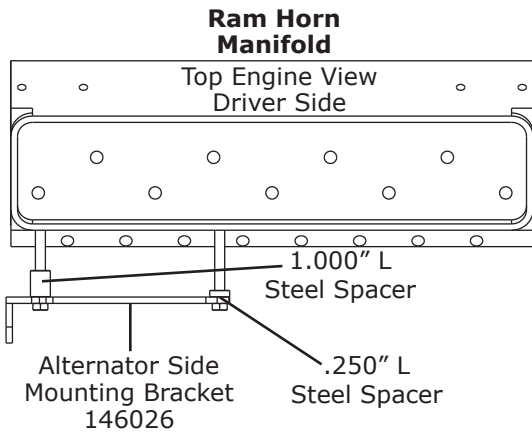
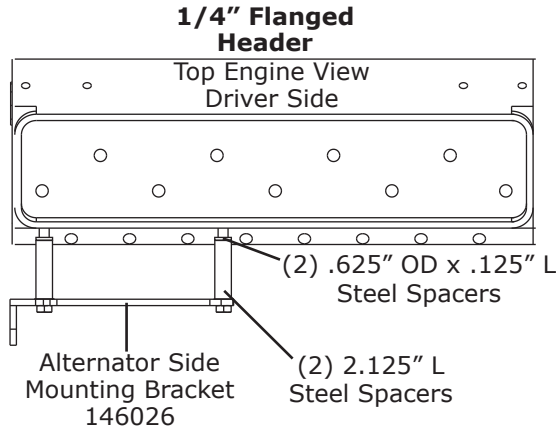

Power Steering Pump Adjuster Bracket Installation

1. Remove the pulley from the power steering pump, and install the power steering pump adjuster bracket onto the pump as shown below.

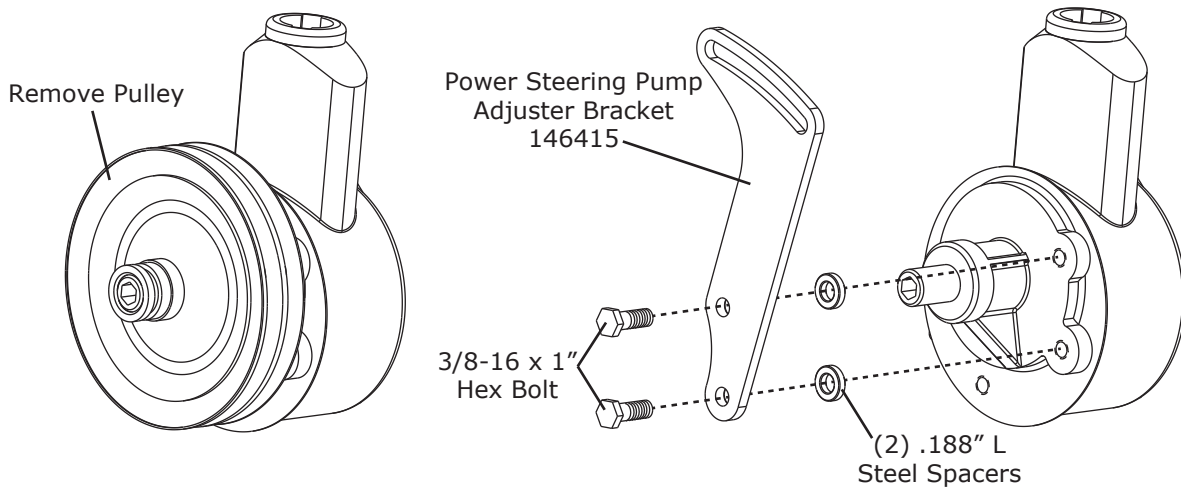

Alternator Adjuster Bracket Installation

1. Install alternator adjuster bracket onto alternator using a 5/16-18 x 1" hex bolt as shown in Figure 2, below.

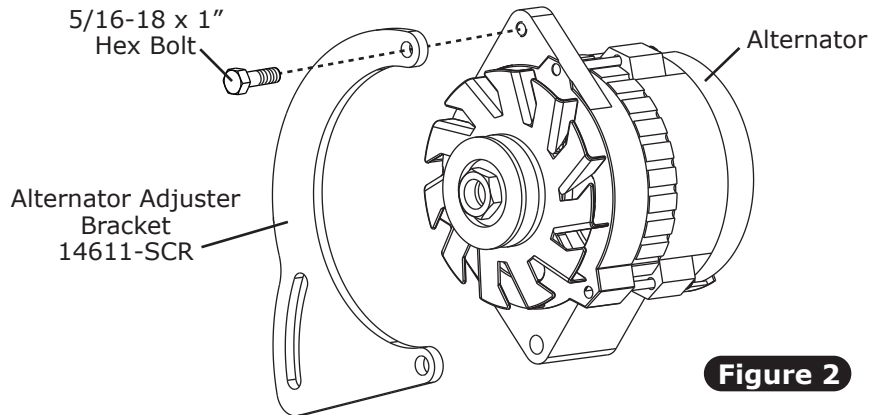

Figure 2

Alternator Front Mounting Bracket Installation

1. Install the alternator front mounting bracket onto the water pump ear as shown in Figure 3, below.

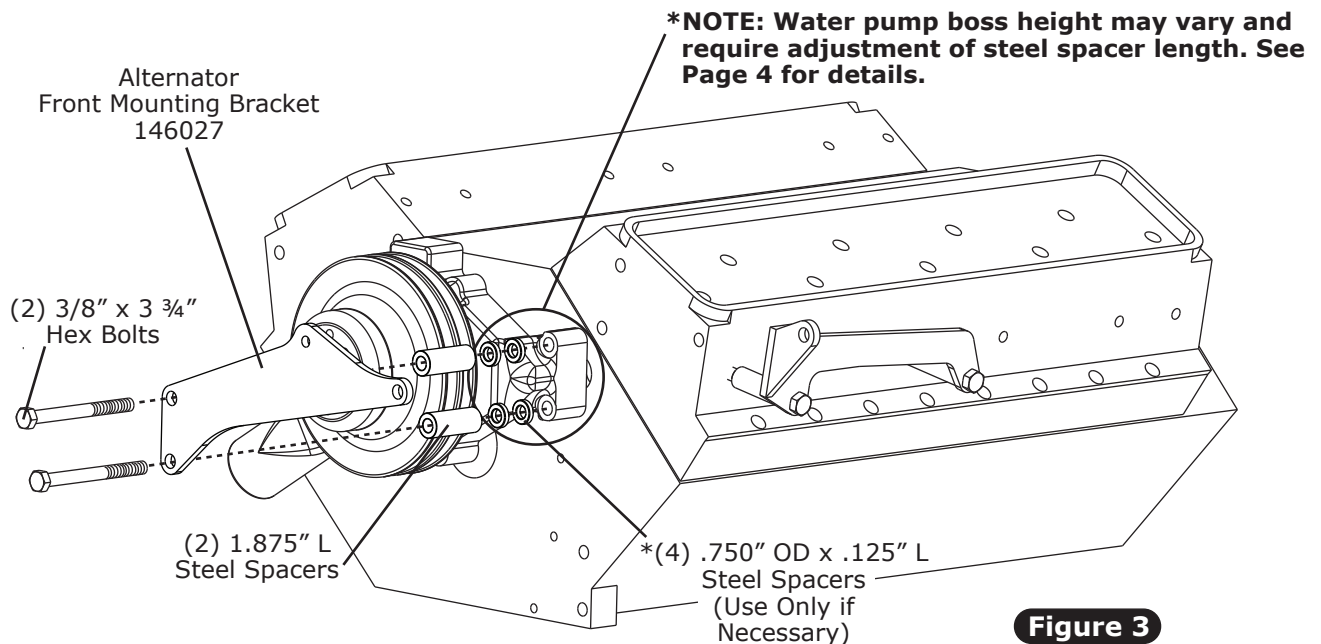

Figure 3

Alternator Assembly Installation

1. Install alternator assembly using a 3/8-16 x 4" hex bolt, a .625" length steel spacer and a 3/8" locknut as shown in Figure 4, below.

NOTE: Alternator assembly is installed behind the alternator bracket and in front of the alternator assembly bracket. Steel spacer is inserted between the alternator and alternator assembly bracket.

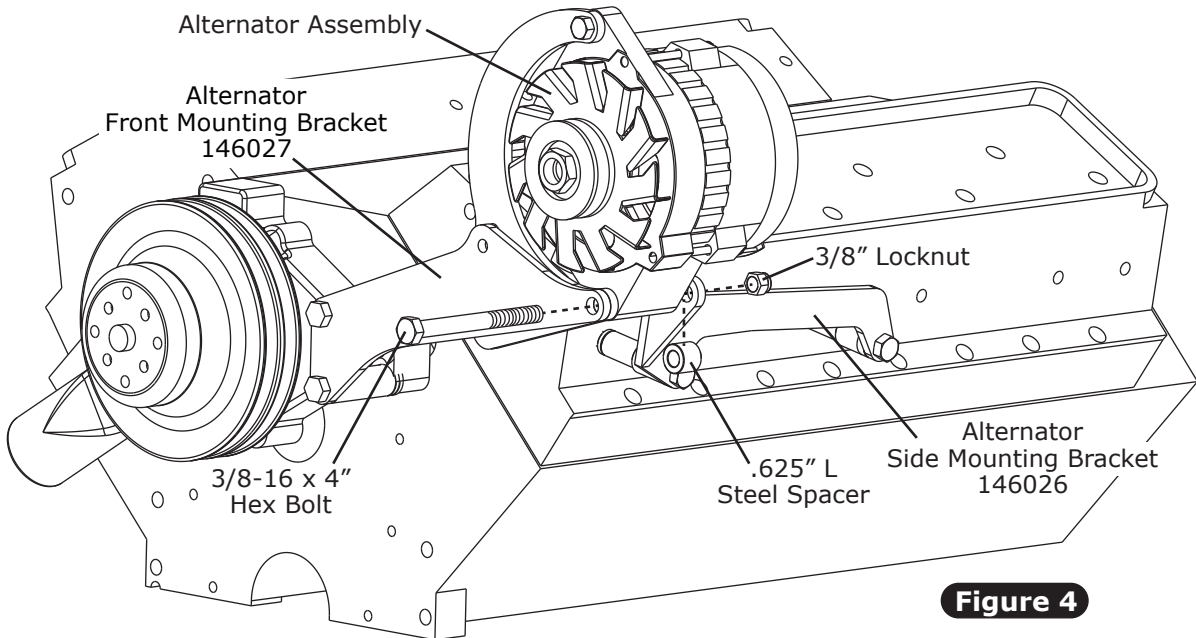

Figure 4

Power Steering Pump Mounting Bracket Installation

1. Install (2) power steering pump mounting brackets onto the power steering pump assembly as shown in Figure 5, below.

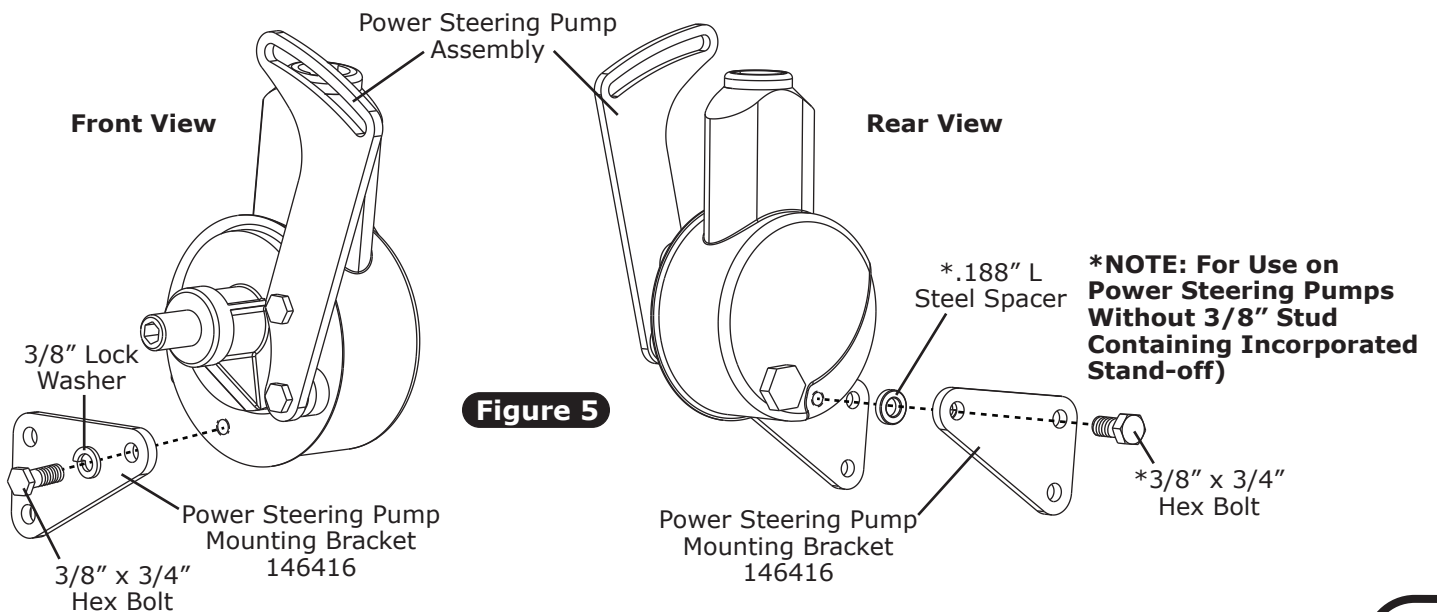
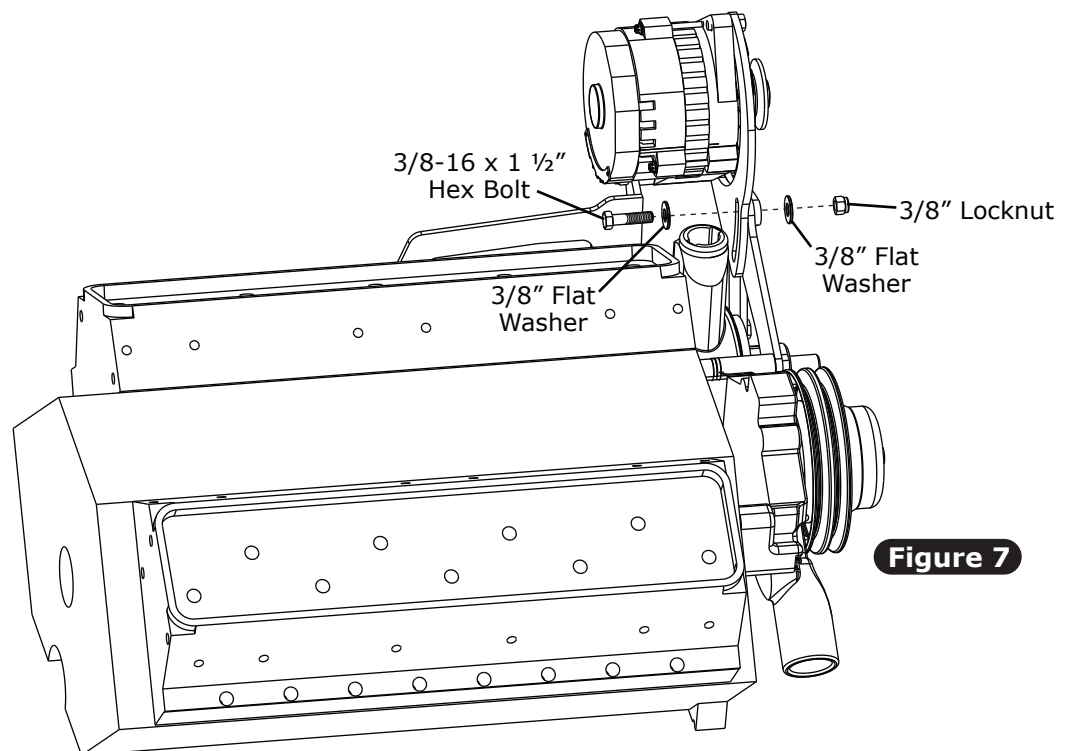
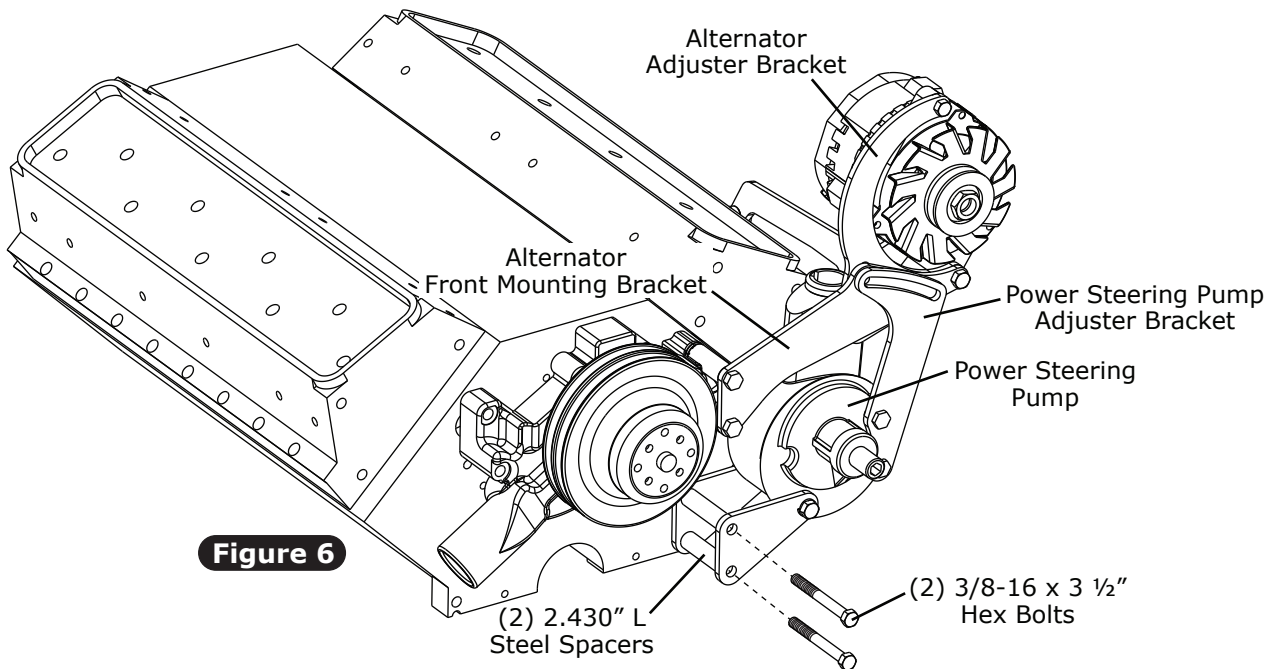

Figure 5

Power Steering Pump Assembly Installation

1. Install the power steering pump assembly using the accessory mounting holes located on the lower driver side of the engine as shown in Figure 6, below.
2. Install a 3/8-16 x 1 1/2" hex bolt and 3/8" flat washer through the back slot of the alternator adjuster bracket, alternator bracket and power steering pump bracket. Secure bolt with a 3/8" flat washer and a 3/8" locknut as shown in Figure 7, below.



Power Steering Pump Pulley Installation

1. Install the power steering pump pulley onto the power steering pump as shown in Figure 8, below. **NOTE: The pulley must be installed with the proper tool (K-D Tool #2897 or equivalent). Do not attempt to hammer or press the pulley onto the power steering pump shaft! Failure to use the proper tool will destroy the pump.**

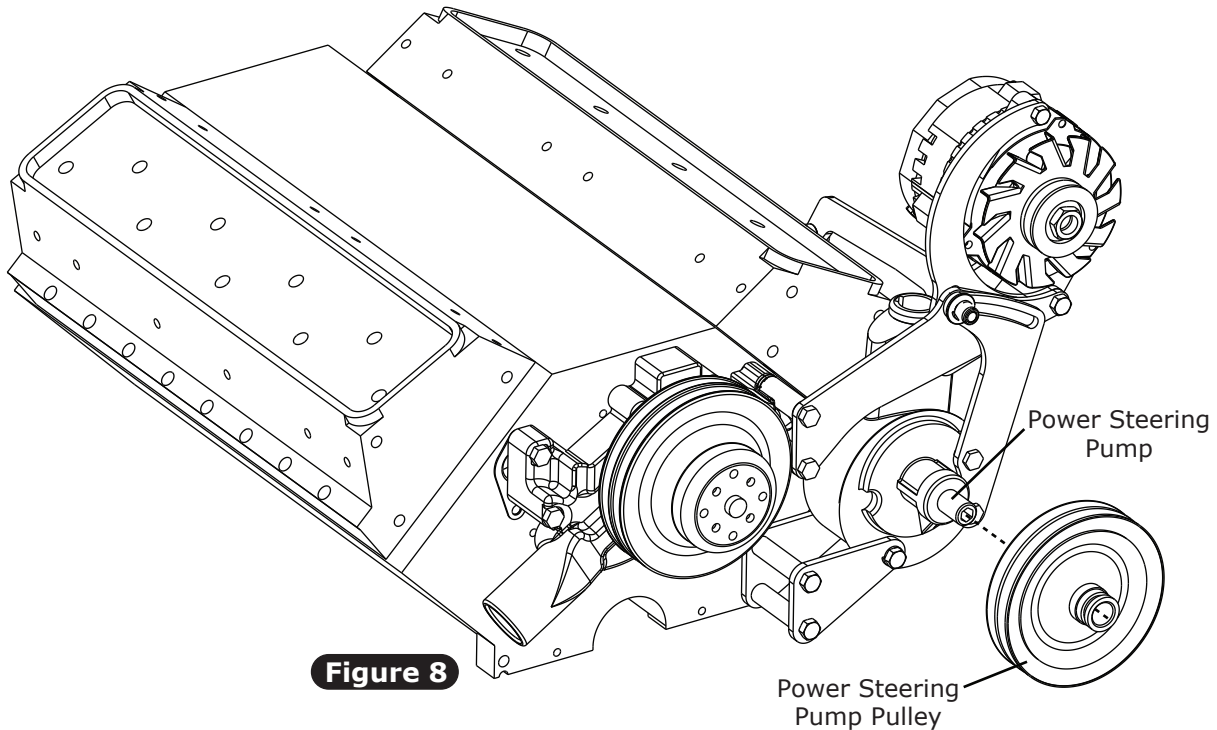

Belt Routing

1. Route belts as shown in Figure 9, below. Vintage Air recommends using only Dayco, Gates or Goodyear brand reinforced V-belts with this alternator/power steering kit. Any use of lesser-quality belts may cause improper performance. Alternator belt length of 57" is recommended. Power steering belt length of 37 1/2" to 38" is recommended. **NOTE: This can vary with diameter of your water pump and crankshaft pulleys.**

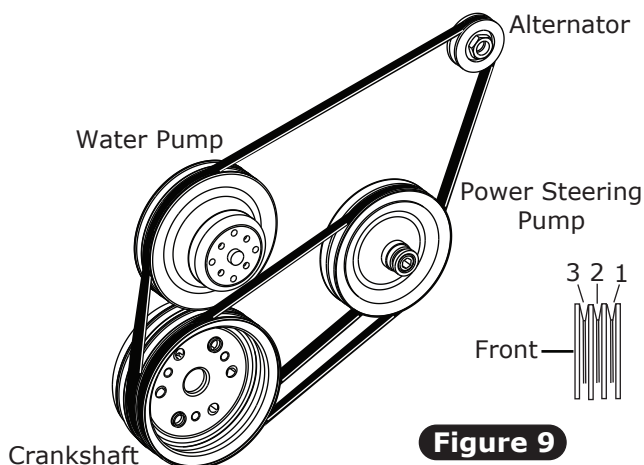

Crankshaft Pulley Grooves:

1. Crankshaft, Compressor and Water Pump (If Applicable)
2. Crankshaft, Water Pump, Alternator and Power Steering Pump
3. Crankshaft and Power Steering Pump



Packing List: Bracket Kit (148000)

No.	Qty.	Part No.	Description
1.	2	146416	Power Steering Pump Mounting Bracket
2.	1	146027	Alternator Front Mounting Bracket
3.	1	14611-SCR	Alternator Adjuster Bracket
4.	1	146026	Alternator Side Mounting Bracket
5.	1	146415	Power Steering Pump Adjuster Bracket
6.	1	191028	Hardware Kit



Checked By: _____
 Packed By: _____
 Date: _____

