



www.kwikperf.com

Installation Instructions for K10472 A/C Bracket for truck or 5th gen Camaro LS3 engines

Scan for installaton
video



Kit contents:

- Mounting plates
- Spacer tubes
- Fasteners
- Idler pulley
- Tensioner

Additional parts required:

- Belt. See chart below.
- AC compressor, Sanden "508" style. Typical SD5 Sanden part number is 6629. However, we recommend the SD7 Sanden part number 4665 for smoother operation and less vibration.

Suggested belt length and Gates PN - K10472 AC bracket - Truck (130+ amp alternator) and 2010+up Camaro spacing						
Factory GM truck Alt/PS bracket and pulley (130+ amp alternator)	Factory GM truck Alt/PS bracket and pulley (105 amp alternator only)	Factory GM 2010+ Camaro Alt/PS bracket and pulley	Kwik Performance Alt/PS bracket K10168			Kwik Performance alternator only bracket K10195
			6.7" diameter power steering pulley	6.0" diameter power steering pulley	5.5" diameter power steering pulley	
112.88" K061123	111.62" K061110	102.6" K061020	99" K060984	98.13" K060975	97.62" K060966 w/"small" alternator 98.13" K060970 w/"large" alternaor	92.13" K060915

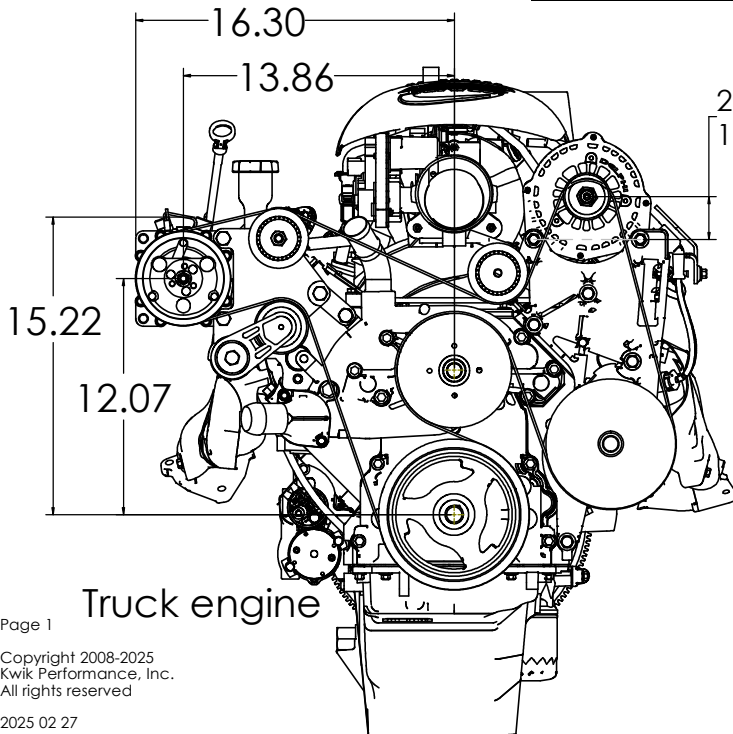

2.19" (130+ amp) "large" alternator
1.68" (105 amp) "small" alternator

Belt installation

Note:
Install belt in rear 6 grooves of the 7 groove compressor.

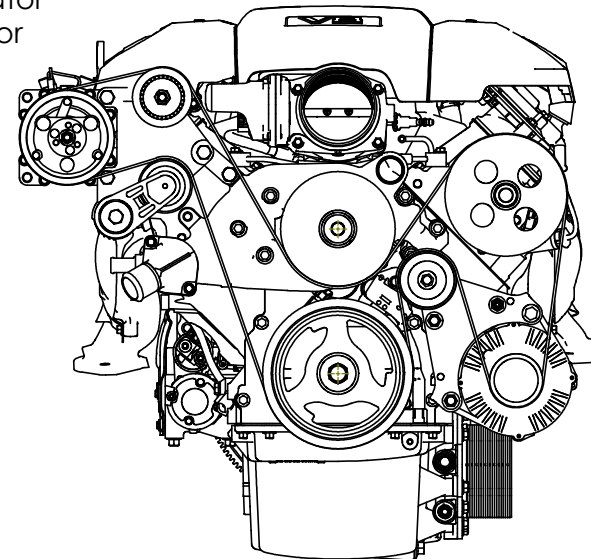



Installation Instructions for K10472

A/C Bracket for LS engines

with truck or 2010+ Camaro balancer

1. Install bracket bolts in head

Leave bolts finger tight to allow adjustment

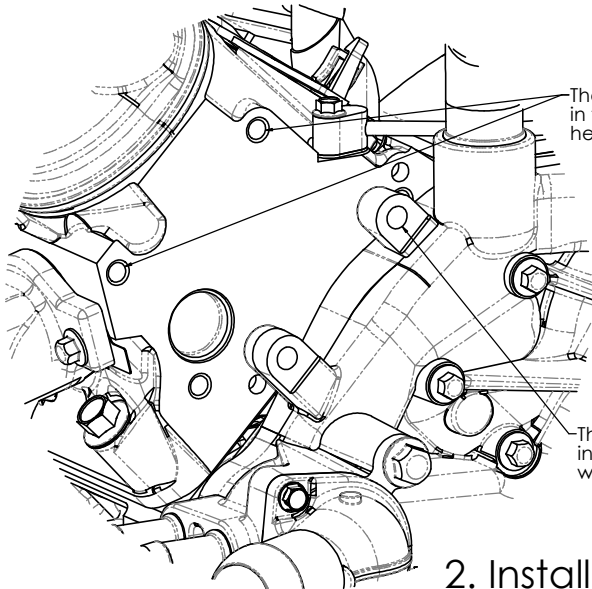

These 2 threaded holes in the passenger side head will be used

This threaded hole in the water pump will be used

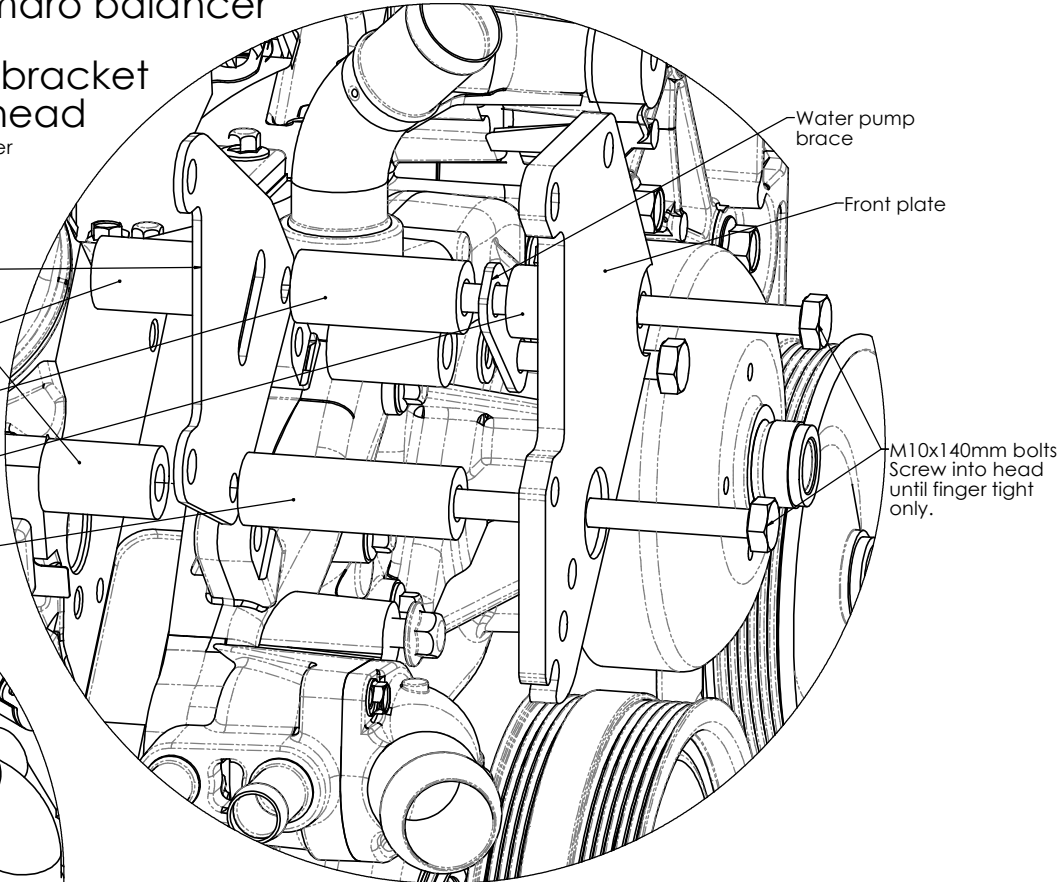

Rear plate

1" OD x 1-9/16 Tubes

1" OD x 2-3/8" Tube

1" OD x 1/2" Tube

1" OD x 3" Tube

Water pump brace

Front plate

M10x140mm bolts
Screw into head until finger tight only.

2. Install Water Pump Bolt

Water pump brace

After all 3 bolts are installed finger tight, lift up on the front plate to take the weight off the bolts, then tighten this bolt first.

After the first head bolt is tightened, tighten this head bolt second.

After the 2 head bolts are tightened, tighten the water pump bolt third.

M10 x 60 bolt (truck)
M10 x 20 bolt (LS3 Camaro)

1" OD x 1-9/16 Tube (truck only)

3/8" washer (LS3 Camaro only)

3. Bolt torque

Tighten 10mm fasteners to 37 ft-lbs (50 N-m)



Installation Instructions for K10472 A/C Bracket for LS engines with truck or 2010+ Camaro balancer

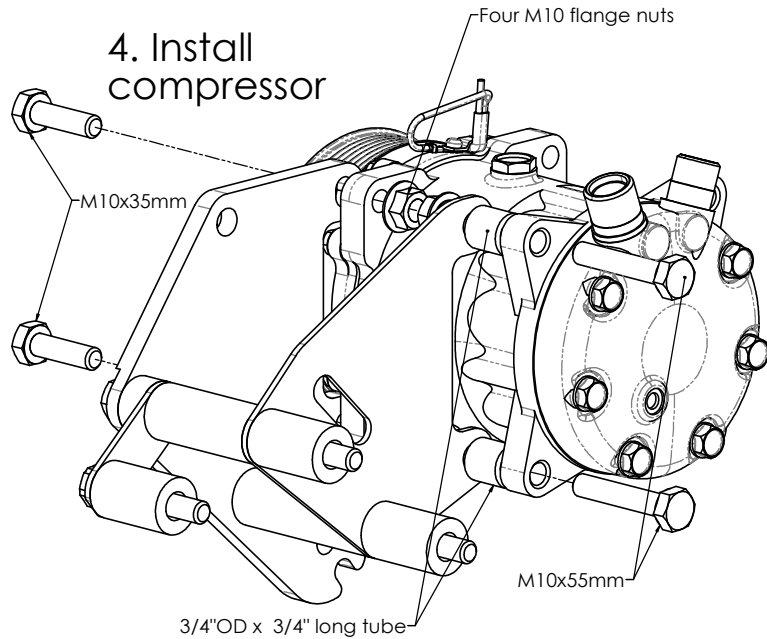

Tighten 10mm fasteners
to 37 ft-lbs (50 N-m)

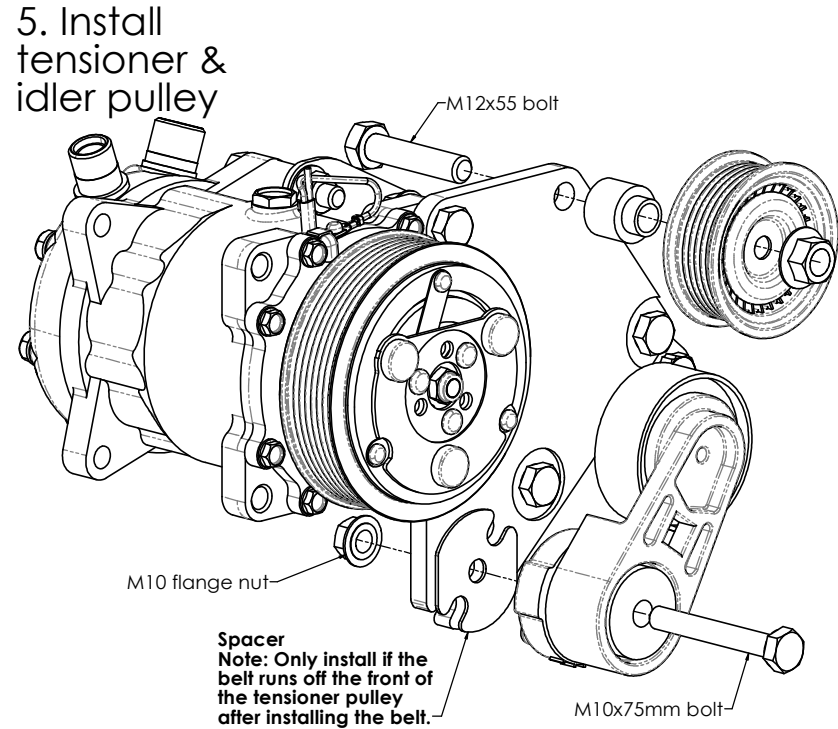

Tighten 10mm fasteners
to 37 ft-lbs (50 N-m),
Tighten 12mm fasteners to
50 ft-lbs (68 N-m).

6. Install belt

See page 1 for belt path and length recommendations

Note:

Install belt in rear 6 grooves of 7 groove 4665 compressor
Install belt in middle 6 grooves of 8 groove 4711 compressor

Note:

For best performance and longest life, the belt lengths suggested by Kwik Performance are the shortest belt that can be reasonably installed.

We recommend the following procedure:

1. When installing the serpentine belt, place the belt around all pulleys as shown in the diagram except for the idler pulley (truck) or the water pump pulley (Camaro).
2. Check to see that the belt is in the correct grooves of the AC compressor.
3. Check to make sure that the belt is seated all the way in the grooves of each grooved pulley.
4. Retract the tensioner all the way and slip the belt onto the idler pulley (truck) or the water pump pulley (Camaro).
5. Release the tensioner.