

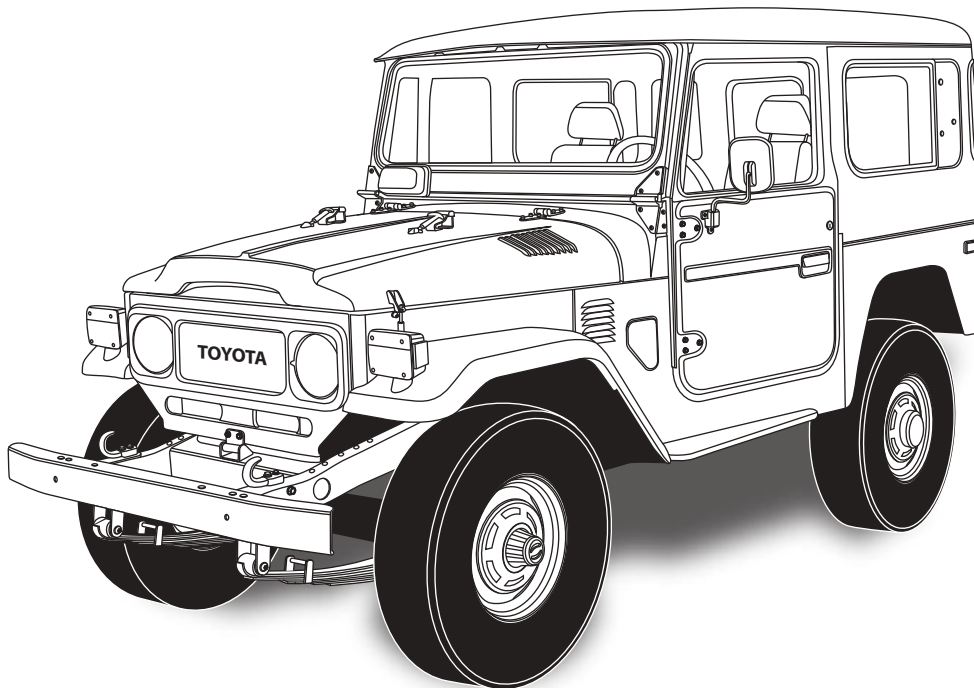

an ISO 9001:2008 Registered Company

# 1968-83 Toyota FJ40

Condenser Kit *with* Drier  
(061200)



18865 Goll St. San Antonio, TX 78266  
Phone: 800-862-6658  
Sales: [sales@vintageair.com](mailto:sales@vintageair.com)  
Tech Support: [tech@vintageair.com](mailto:tech@vintageair.com)  
[www.vintageair.com](http://www.vintageair.com)



[www.vintageair.com](http://www.vintageair.com)

# Table of Contents

**Thank you for purchasing this condenser kit from Vintage Air. When installing these components as part of a complete SureFit™ system, Vintage Air recommends working from front to back on the vehicle, installing the condenser kit, hose kit, and compressor first, followed by the wiring, evaporator, and finally the control panel.**

Cover.....	1
Table of Contents.....	2
Packing List/Parts Disclaimer.....	3
Information Page.....	4
Core Support Measurements.....	5
Engine Compartment Disassembly, Core Support Modification.....	6
Core Support Modification (Cont.).....	7
Condenser Mounting Bracket Installation.....	8
Drier Installation, Hardline and Binary Switch Installation.....	9
Hardline and Binary Switch Installation (Cont.), Lubricating O-rings.....	10
Grille Emblem Modification.....	11
Core Support Installation, Final Steps.....	12
Packing List.....	13



www.vintageair.com

## Packing List: Condenser Kit (061200)

No.	Qty.	Part No.	Description
1.	1	037036	Condenser, 17" x 19", Parallel Flow
2.	1	07321-VUC	Drier
3.	1	11079-VUS	Binary Switch, Male
4.	1	23135-VUW	Compressor Lead
5.	2	18425-VUB	Washer, 7/16"
6.	2	18514-VUB	Push-on Ring, 3/8"
7.	1	648253	Bracket, Condenser, Top
8.	1	648252	Bracket, Condenser, Bottom
9.	1	648255	Bracket, Drier
10.	1	121035	Hardline, #8 Condenser/Core
11.	1	121036	Hardline, #6 Condenser/Drier
12.	1	33857-VUF	O-ring, #6
13.	1	33858-VUF	O-ring, #8
14.	9	18247-VUB	Screw, #10 x 1/2", Sheet Metal
15.	7	18979-VUB	J-Nut
16.	3	18152-VUB	Nut with Star Washer, 1/4-20
17.	1	186011	Washer, 1/4"
18.	2	18287-VUB	Hex Bolt, 1/4-20 x 1/2"
19.	1	182479	Screw, 10-24 x 1/2"
20.	1	31603-VUD	Adel Clamp, #4

**\*\* Before beginning installation, open all packages and check contents of shipment. Please report any shortages directly to Vintage Air within 15 days. After 15 days, Vintage Air will not be responsible for missing or damaged items.**

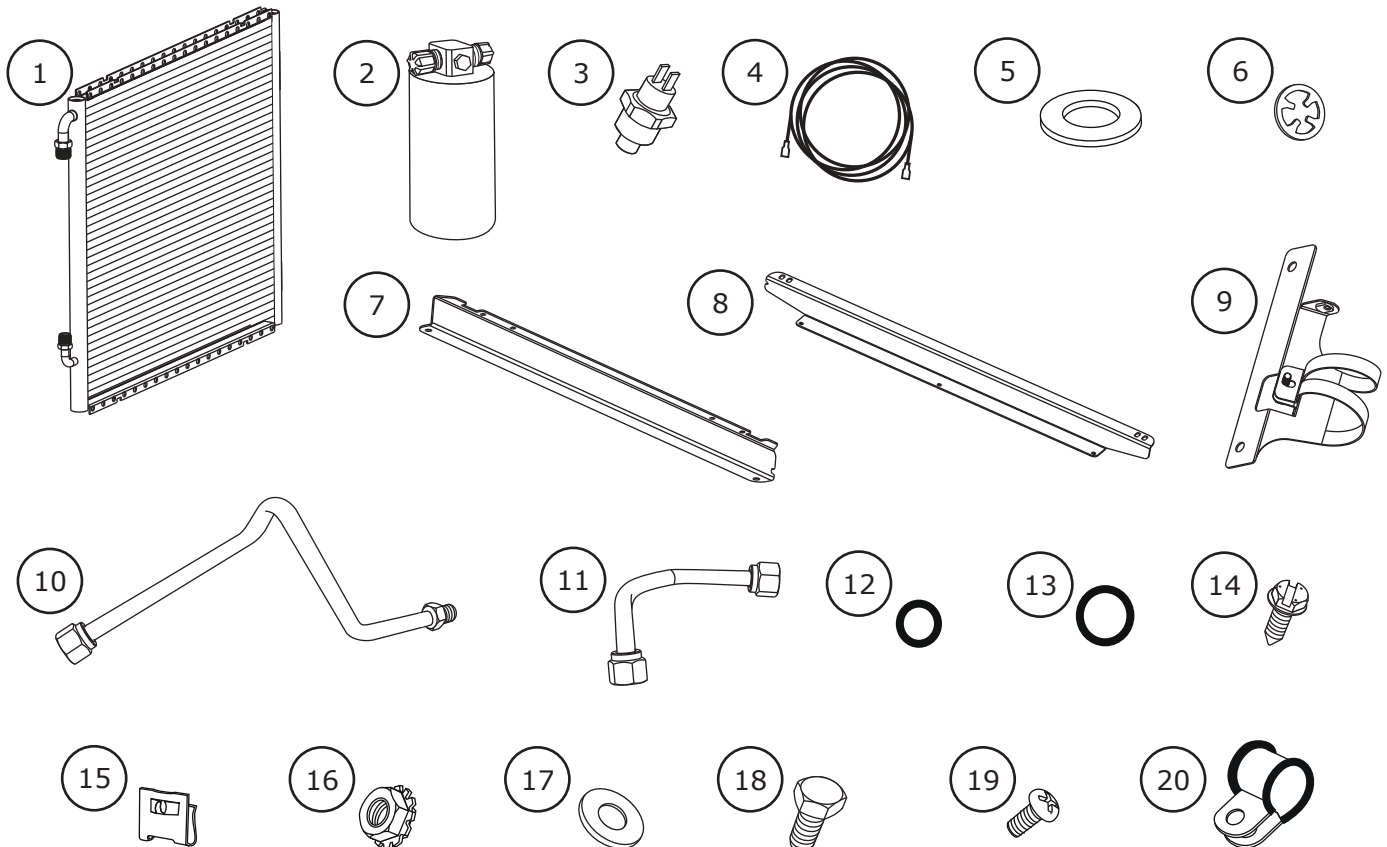

**NOTE: Images may not depict actual parts and quantities. Refer to packing list for actual parts and quantities.**



www.vintageair.com

## Important Notice—Please Read

*For Maximum System Performance, Vintage Air Recommends the Following:*

**NOTE: Vintage Air systems are designed to operate with R134a refrigerant only. Use of any other refrigerant could damage your A/C system and/or vehicle, and possibly cause a fire, in addition to potentially voiding the warranties of the A/C system and its components.**

### Refrigerant Capacities:

**Vintage Air System:** 1.8 lbs. (1 lb., 12 oz.) of **R134a**, charged by weight with a quality charging station or scale. **NOTE: Use of the proper type and amount of refrigerant is critical to system operation and performance.**

**Other Systems:** Consult manufacturer's guidelines.

### Lubricant Capacities:

**New Vintage Air-supplied Sanden Compressor:** No additional oil needed (Compressor is shipped with proper oil charge).

**All Other Compressors:** Consult manufacturer (Some compressors are shipped dry and will need oil added).

### Safety Switches

Your Vintage Air system is equipped with a binary pressure safety switch. A binary switch disengages the compressor clutch in cases of extreme low pressure conditions (Refrigerant Loss) or excessively high head pressure (406 PSI) to prevent compressor damage or hose rupture. A trinary switch combines Hi/Lo pressure protection with an electric fan operation signal at 254 PSI, and should be substituted for use with electric fans. Compressor safety switches are extremely important since an A/C system relies on refrigerant to circulate lubricant.

### Service Info:

**Protect Your Investment:** Prior to assembly, it is critical that the compressor, evaporator, A/C hoses and fittings, hardlines, condenser and receiver/drier remained capped. Removing caps prior to assembly will allow moisture, insects and debris into the components, possibly leading to reduced performance and/or premature failure of your A/C system. This is especially important with the receiver/drier.

Additionally, when caps are removed for assembly, **BE CAREFUL!** Some components are shipped under pressure with dry nitrogen.

**Evacuate the System for 35-45 Minutes:** Ensure that system components (Drier, compressor, evaporator and condenser) are at a temperature of at least 85° F. On a cool day, the components can be heated with a heat gun **or** by running the engine with the heater on before evacuating. Leak check and charge to specifications.

### Bolts Passing Through Cowl and/or Firewall:

To ensure a watertight seal between the passenger compartment and the vehicle exterior, for all bolts passing through the cowl and/or firewall, Vintage Air recommends coating the threads with silicone prior to installation.

### Heater Hose (Not Included With This Kit):

Heater hose may be purchased from Vintage Air (Part# 31800-VUD) or your local parts retailer. Routing and required length will vary based on installer preference.



www.vintageair.com

## Core Support Measurements

This kit was developed based on the measurements below, which were taken from a 1974 Toyota FJ40 without factory air.

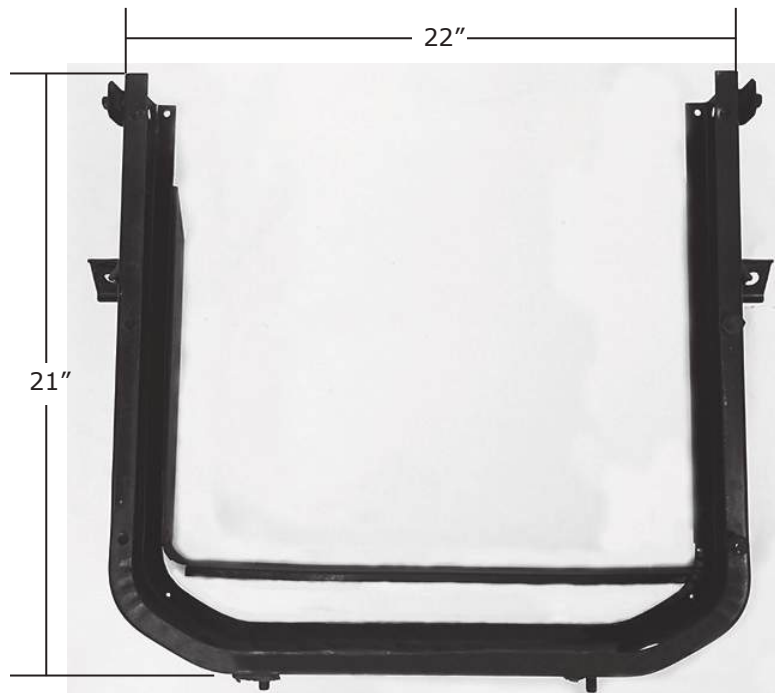



www.vintageair.com

## Engine Compartment Disassembly

**NOTE: Before starting the installation, check the function of the vehicle (horn, lights, etc.) for proper operation, and study the instructions, illustrations, & diagrams.**

### Perform the Following:

1. Disconnect the battery.
2. Remove the battery (retain).
3. Drain the radiator.
4. Remove the radiator and the fan shroud by removing (6) or (7) bolts on the core support (retain) (See Photo 1, below).
5. Remove the core support by removing (2) core support rods, and (2) nuts and washers from beneath the frame (retain) (See Photos 1 and 2, below).

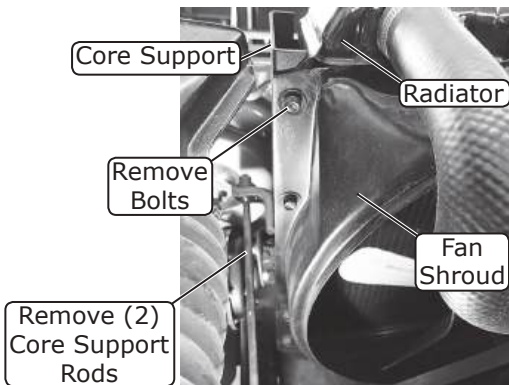

Photo 1

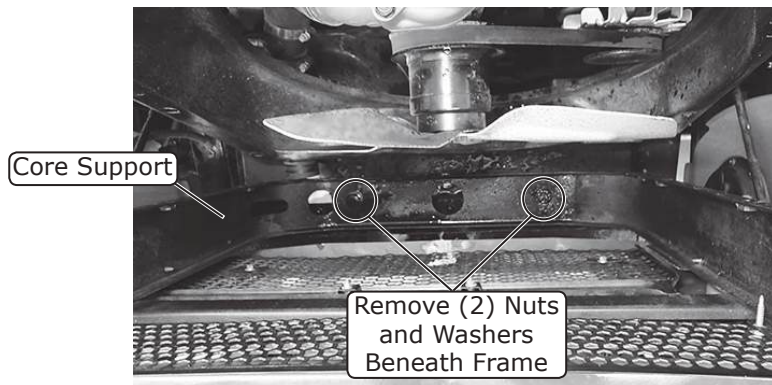

Photo 2

## Core Support Modification

**NOTE: In some cases, it may be necessary to modify the core support mounting location to provide sufficient clearance for the condenser in front of the radiator. If the core support sits directly behind the grille, follow Steps 1-3, below, to modify the core support mounting studs. If sufficient clearance exists between the core support and the grille, proceed to Step 4 on Page 7.**

1. Cut the core support mounting studs flush with the bottom of the core support as shown in Photos 3 and 4, below.
2. Measure forward approximately 1 1/4" from the original mounting stud locations, and drill (2) 3/8" holes through the bottom of the core support (See Photo 4, below).
3. Insert (2) 3/8" bolts (not supplied) into the (2) 3/8" holes on the core support (See Photo 5, below).

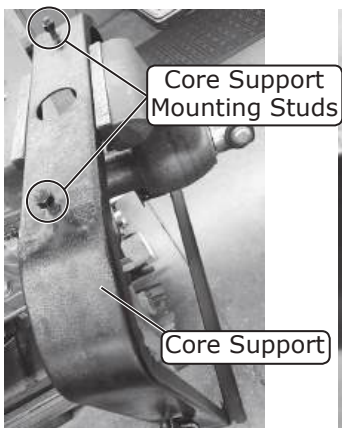

Photo 3

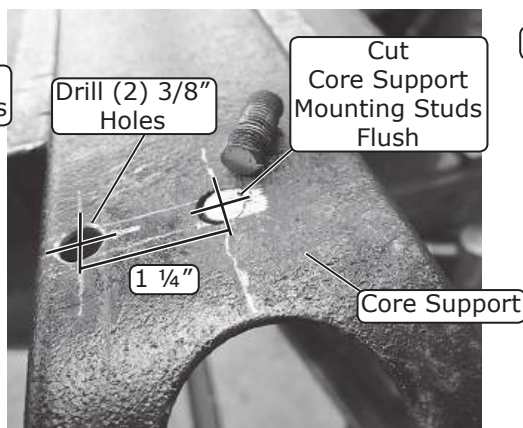

Photo 4

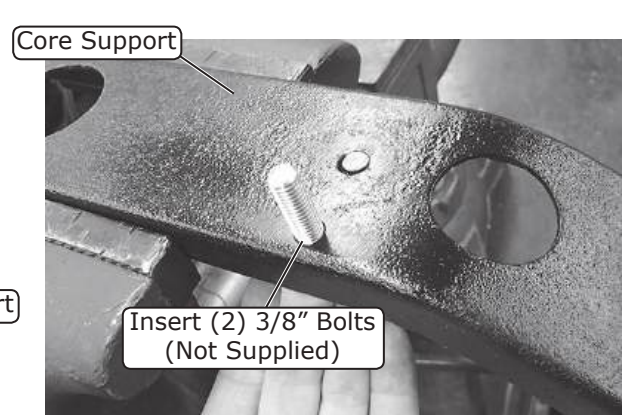

Photo 5



www.vintageair.com

## Core Support Modification (Cont.)

**NOTE: Step 10 applies only to core supports with a baffle. If no baffle is present, after Step 9, proceed to Condenser Mounting Bracket Installation on Page 8.**

4. Place the core support on a workbench with the front side facing up as shown in Photo 6, below.
5. Place the condenser top mounting bracket onto the core support, aligning the bracket evenly with the top corners as shown in Photo 7, below.
6. Clamp the bracket into place, and mark the mounting hole locations on the core support as shown in Photo 7, below.
7. At the marked locations, drill a 1/4" hole into each side of the core support.
8. Temporarily install the condenser top bracket onto the core support using (2) 1/4-20 x 1/2" hex bolts and (2) 1/4-20 nuts with star washers (See Photo 8, below).
9. Remove the horizontal brace from the core support (See Photos 8 and 9, below). **NOTE: The brace is spot welded to the core support.**
10. If the core support has a baffle (See Photo 10, below), it will need to be modified to provide clearance for the hardlines. On the passenger side of the core support baffle, measure and mark 9 3/4" down from the top edge of the core support (See Photo 10, below). Then, measure and mark 12" down from the top edge of the core support. Remove this section from the baffle as shown in Photo 11, below.

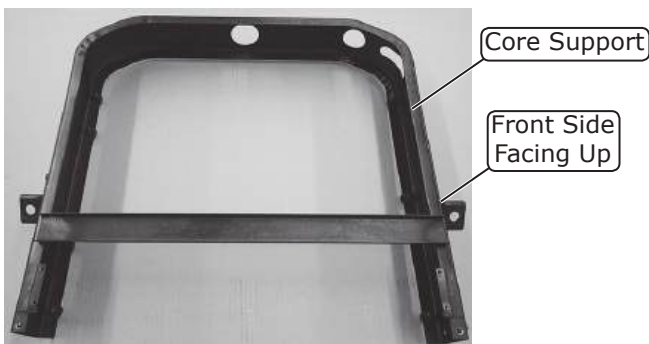

Photo 6

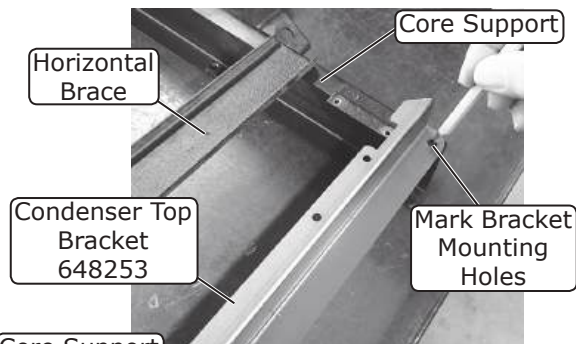

Photo 7

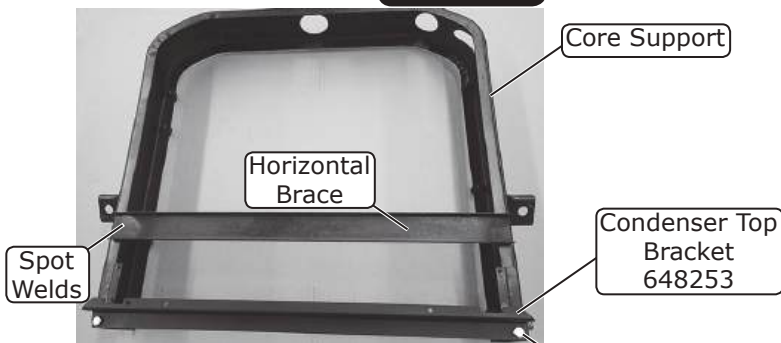

Photo 8



Photo 9

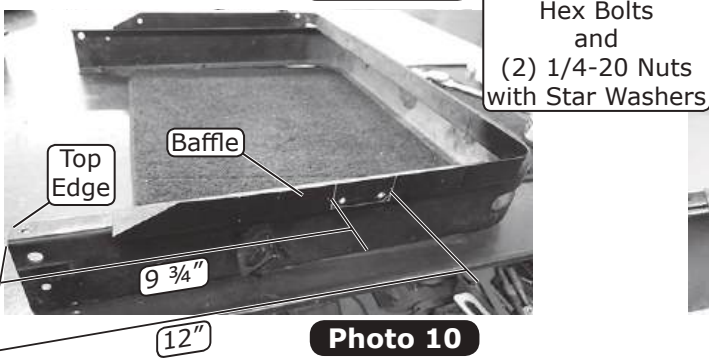

Photo 10



Photo 11



www.vintageair.com

## Condenser Mounting Bracket Installation

1. Install (7) J-nuts onto the front mounting flanges on the condenser (See Photos 12 and 13, below). **NOTE: Install (4) J-nuts onto the top mounting flange at the 1st and 3rd holes from each end of the condenser. Install (3) J-nuts onto the bottom mounting flange at the 1st, 9th and 18th holes (See Photo 13, below).**
2. Remove the condenser top bracket from the core support, and install it onto the condenser using (4) #10 x 1/2" sheet metal screws (See Photo 14, below). Install the condenser bottom bracket onto the condenser using (3) #10 x 1/2" sheet metal screws (See Photo 14, below).
3. Place the condenser assembly onto the front of the core support. Secure the condenser top bracket to the core support using the (2) 1/4-20 x 1/2" hex bolts and (2) 1/4-20 nuts with star washers (See Photo 15, below).
4. Using the condenser bottom bracket as a guide, mark and drill (2) 5/32" holes into the core support (See Photo 16, below). **NOTE: The bottom bracket has (2) slots on each side. Use the slot that best fits the core support (See Photo 16, below).**
5. Secure the condenser bottom bracket to the core support using (2) #10 x 1/2" sheet metal screws (See Photo 17, below).

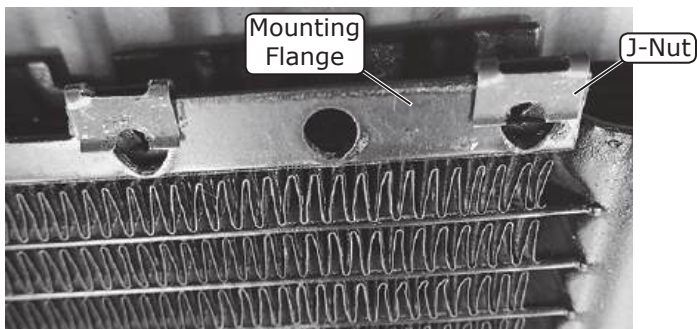

Photo 12

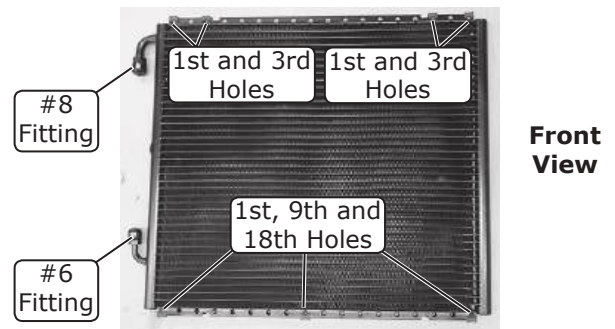

Photo 13

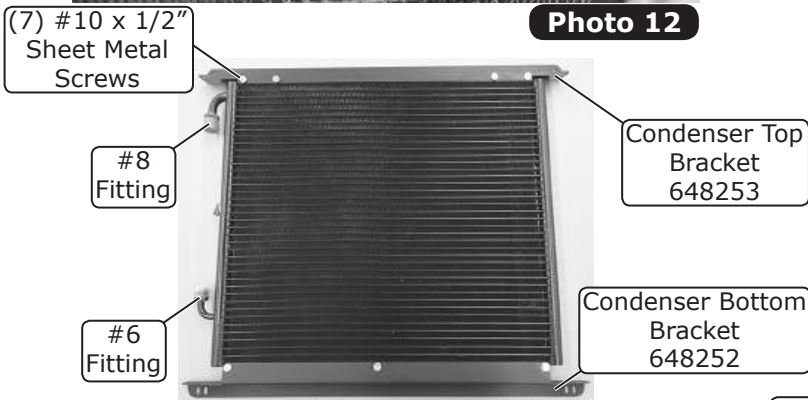

Photo 14



Photo 15

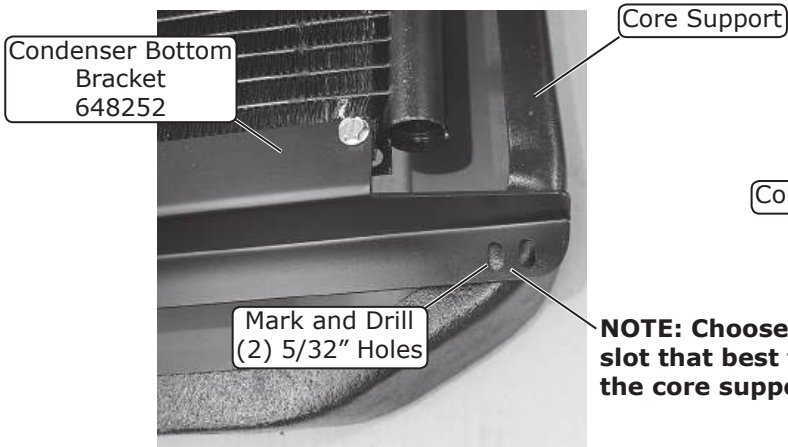

Photo 16

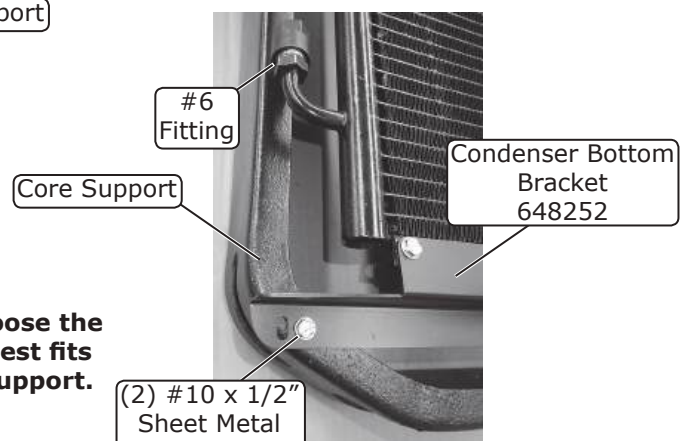

Photo 17

**NOTE: Choose the slot that best fits the core support.**





www.vintageair.com

## Drier Installation

**NOTE: Do not remove the caps from the drier. The drier contains a desiccant that will quickly absorb moisture from the air, causing it to lose effectiveness. For this reason, Vintage Air recommends that the drier remains capped until the installer is ready to evacuate the system.**

### Perform the Following:

1. Install the drier bracket onto the engine side of the core support using (2) OEM bolts (See Photo 18, below).
2. Install the drier into the drier bracket, and secure it using a 1/4" washer and a 1/4" nut with star washer (See Photo 19, below). **NOTE: Refrigerant flow through the drier is IN from condenser, OUT to evaporator. Do not fully tighten the nut at this time.**

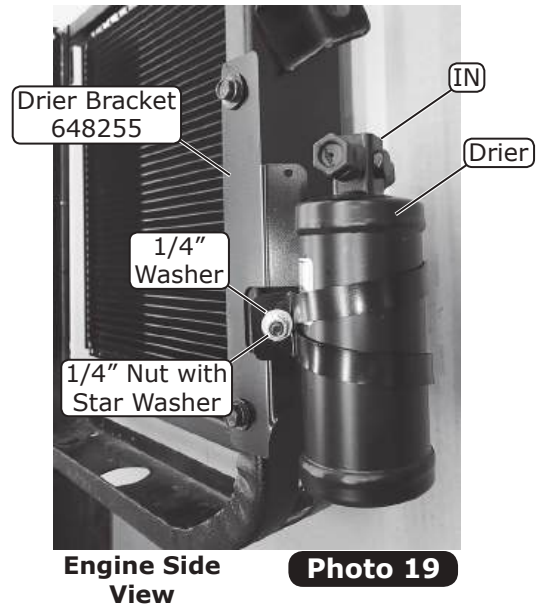
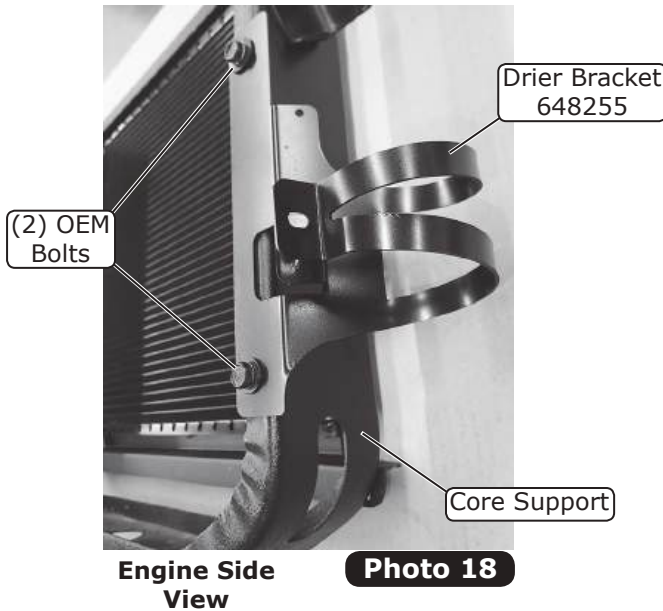

## Hardline and Binary Switch Installation

1. Lubricate (2) #6 O-rings, and install one onto each end of the #6 condenser/core hardline (See Figure 1, Page 10). Install the end of the hardline with the 90° bend onto the #6 condenser fitting (See Photo 20, below).
2. Align and install the opposite end of the #6 condenser/drier hardline onto the drier at the IN fitting (See Photo 21, below). Tighten both ends of the hardline (See Figure 1, Page 10). **NOTE: Tighten the 1/4" nut with star washer securing the drier to the drier bracket at this time.**

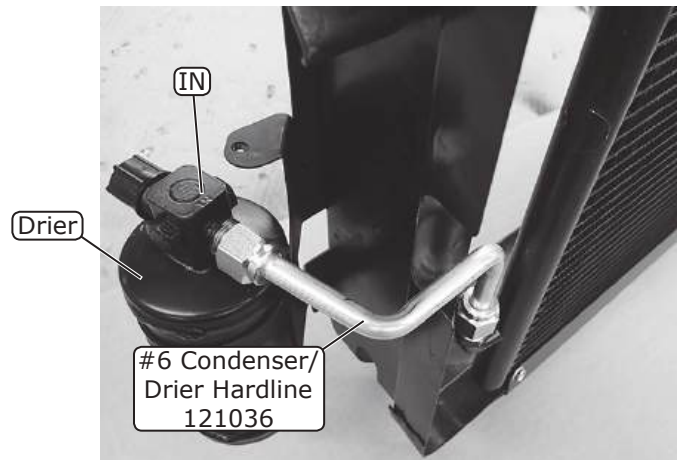
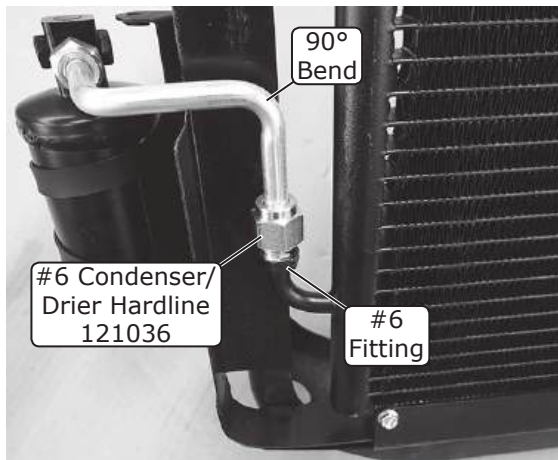



www.vintageair.com

## Hardline and Binary Switch Installation (Cont.)

- Lubricate a #8 O-ring, and install it onto the female end of the #8 condenser/core hardline (See Figure 1, below). Install the #8 condenser/core hardline onto the #8 condenser fitting as shown in Photo 22, below. **NOTE: Do not fully tighten the #8 hardline at this time. If the core support has a baffle, the #6 and #8 hardlines will pass through the opening (See Photo 23, below).**
- Secure the #8 condenser/core hardline onto the drier bracket tab using a #4 Adel clamp and a 10-24 x 1/2" screw as shown in Photo 23, below. Fully tighten the #8 condenser/core hardline on the #8 condenser fitting at this time. **NOTE: The opposite end of the #8 condenser/core hardline will connect to the #8 A/C hose leading to the compressor.**
- Install the binary switch onto the drier with a properly lubricated O-ring (See Photo 24, below). **NOTE: The binary switch and the drier each come with an O-ring. Only one of the (2) O-rings will be used.**



Photo 22

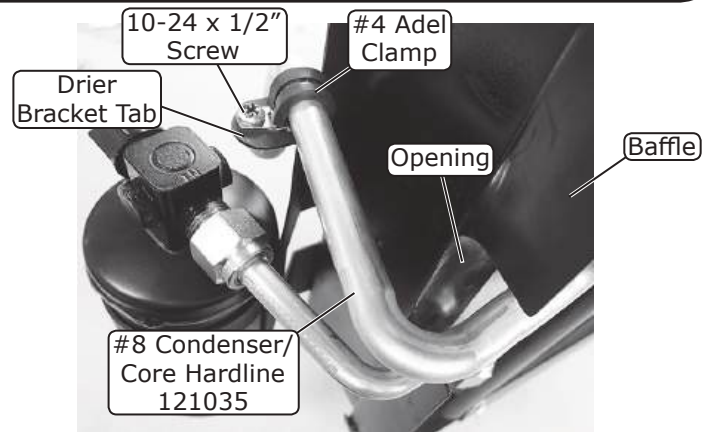

Photo 23

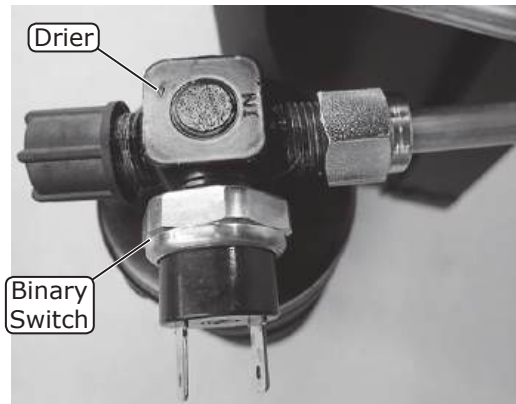

Photo 24

### Lubricating O-rings

For a proper seal of fittings: Install supplied O-rings as shown, and lubricate with supplied oil.

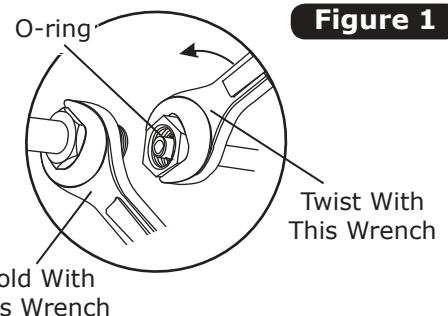
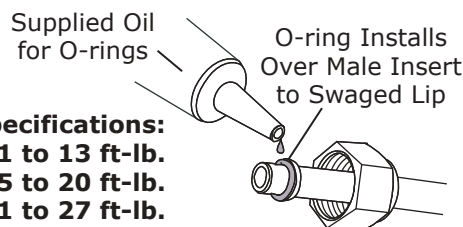
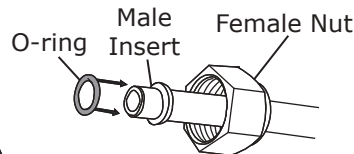
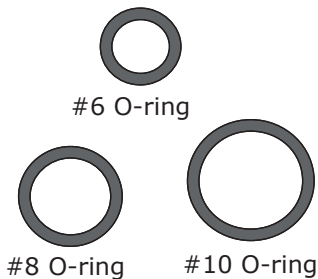

Figure 1

**NOTE: Standard torque specifications:**  
 #6: 11 to 13 ft-lb.  
 #8: 15 to 20 ft-lb.  
 #10: 21 to 27 ft-lb.



www.vintageair.com

## Grille Emblem Modification

**NOTE: The Toyota grille emblem must be modified to prevent it from hitting the condenser during and after installation.**

1. Remove the Toyota grille emblem (See Photos 25 and 26, below), and cut the mounting screws flush with the plastic extensions as shown in Photos 27 and 28, below.
2. Round off the top edge of the plastic extensions with a file (See Photo 28, below), and insert the emblem through the grille bar in the original location (See Photo 29, below).
3. Secure the emblem to the grille bar using (2) 7/16" washers and (2) 3/8" push-on rings as shown in Photo 29, below. **NOTE: The push-on rings install onto the plastic extensions with the spring tabs pointing toward the engine.**



Photo 25



Photo 26

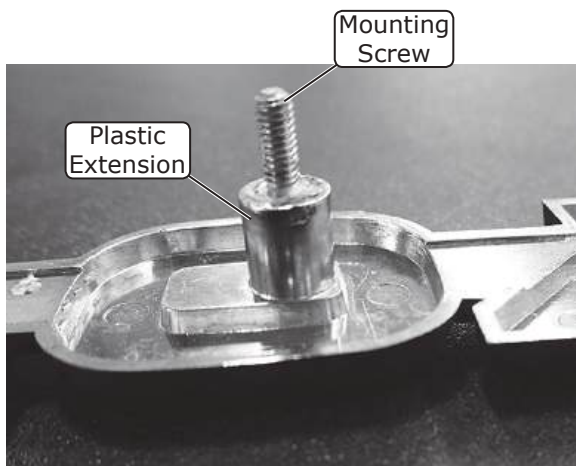

Photo 27

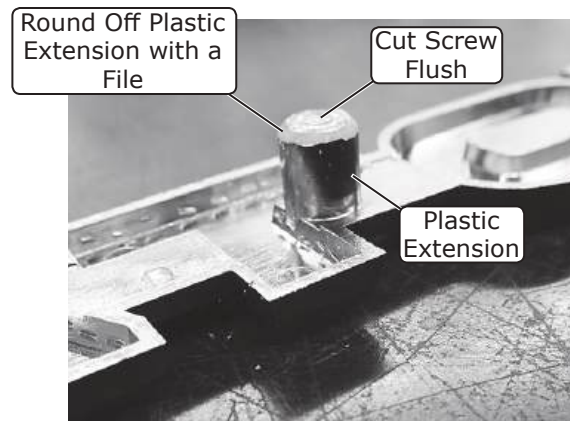

Photo 28

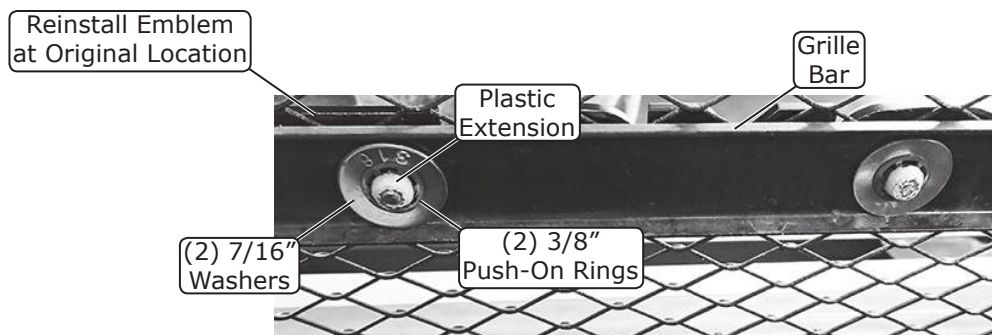

Photo 29



www.vintageair.com

## Core Support Installation

1. Place the fan shroud behind the fan (See Photo 30, below), and place the core support assembly (with the (2) studs facing toward the bottom) onto the (2) brackets/pads on the frame crossmember. Secure the core support using (2) OEM washers and nuts underneath the frame (See Photos 31 and 32, below). Reinstall the core support rods onto each side of the core support (See Photo 33, below).
2. From the top, slide the radiator into the core support (See Photo 34, below). Remove the (2) OEM bolts holding the drier bracket assembly onto the core support, and slide the bracket over the radiator and fan shroud flanges (See Photo 35, below).
3. Secure the radiator, the fan shroud and the drier bracket assembly to the core support using the OEM bolts.

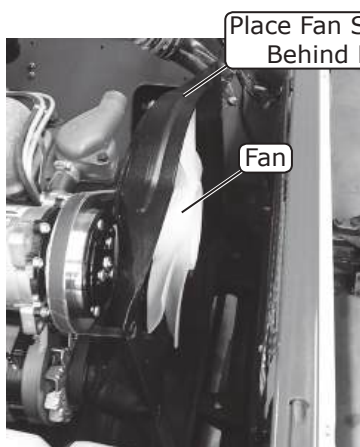

Photo 30

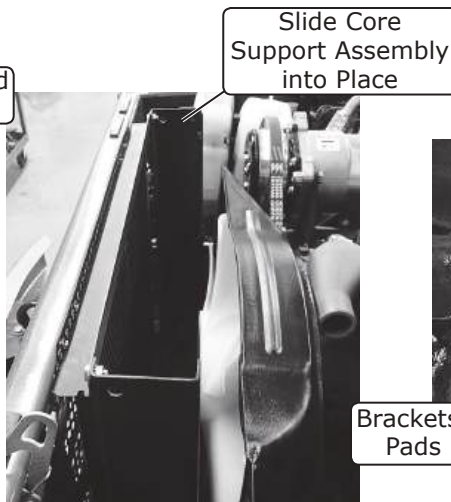

Photo 31

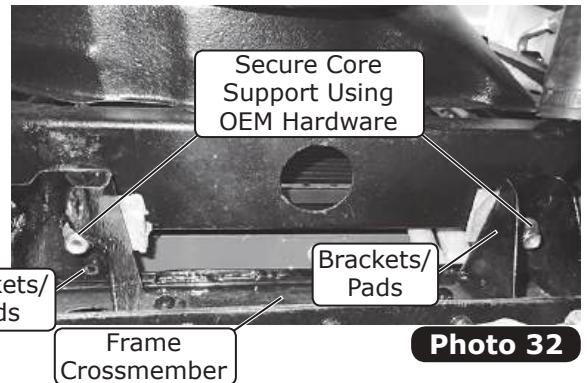

Photo 32

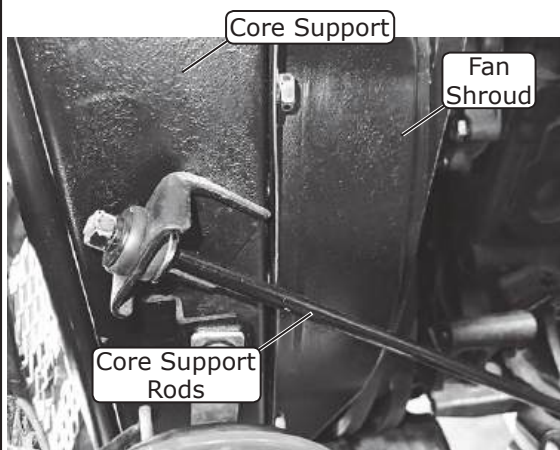

Photo 33

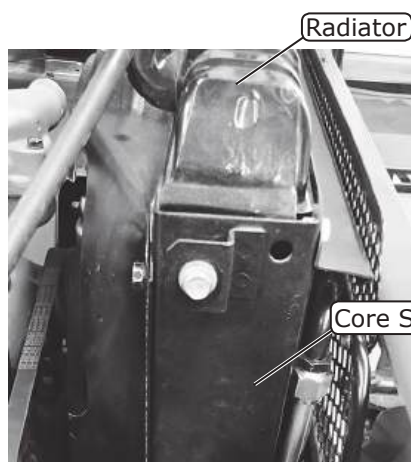

Photo 34

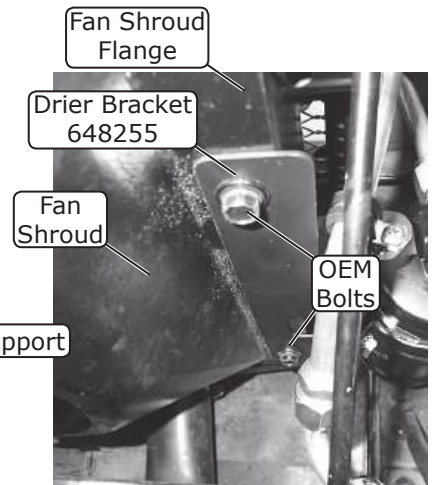

Photo 35

## Final Steps

1. Reinstall and/or reconnect all remaining items removed or disconnected in the Engine Compartment Disassembly instructions on Page 6. This concludes the condenser kit portion of your installation.





www.vintageair.com

## Packing List: Condenser Kit (061200)

No.	Qty.	Part No.	Description
1.	1	037036	Condenser, 17" x 19", Parallel Flow
2.	1	07321-VUC	Drier
3.	1	11079-VUS	Binary Switch, Male
4.	1	23135-VUW	Compressor Lead
5.	2	18425-VUB	Washer, 7/16"
6.	2	18514-VUB	Push-on Ring, 3/8"
7.	1	648253	Bracket, Condenser, Top
8.	1	648252	Bracket, Condenser, Bottom
9.	1	648255	Bracket, Drier
10.	1	121035	Hardline, #8 Condenser/Core
11.	1	121036	Hardline, #6 Condenser/Drier
12.	1	33857-VUF	O-ring, #6
13.	1	33858-VUF	O-ring, #8
14.	9	18247-VUB	Screw, #10 x 1/2", Sheet Metal
15.	7	18979-VUB	J-Nut
16.	3	18152-VUB	Nut with Star Washer, 1/4-20
17.	1	186011	Washer, 1/4"
18.	2	18287-VUB	Hex Bolt, 1/4-20 x 1/2"
19.	1	182479	Screw, 10-24 x 1/2"
20.	1	31603-VUD	Adel Clamp, #4

Checked By: \_\_\_\_\_  
Packed By: \_\_\_\_\_  
Date: \_\_\_\_\_

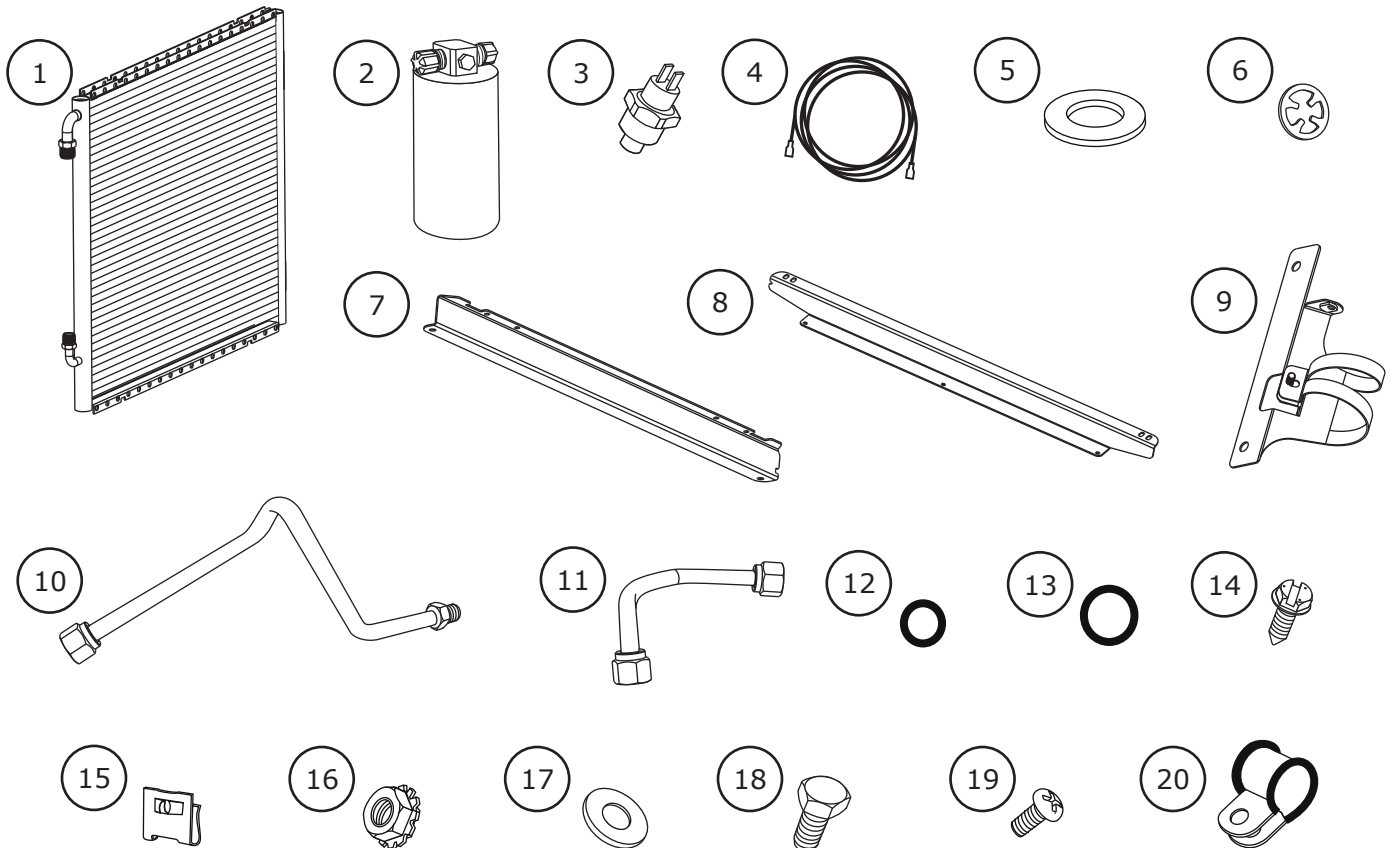

**NOTE: Images may not depict actual parts and quantities.  
Refer to packing list for actual parts and quantities.**