



1970 Plymouth Road Runner

Condenser Kit *with* Drier
(051069)



18865 Goll St. San Antonio, TX 78266

Phone: 210-654-7171

Sales: sales@vintageair.com

Tech Support: tech@vintageair.com

www.vintageair.com



www.vintageair.com

Table of Contents

Cover.....	1
Table of Contents/Parts Disclaimer.....	2
Information Page.....	3
Core Support Measurements.....	4
Engine Compartment Disassembly, Drier Installation.....	5
Mounting Bracket Installation, Lubricating O-rings.....	6
#6 Drier/Condenser Hardline & Binary Switch Installation, Nylon Spacer Installation.....	7
Condenser Installation.....	8
#6 and #8 Hardline Installation.....	9
Securing Hardlines, Final Steps.....	10
Packing List.....	11

Parts Disclaimer: Please Read

Before beginning installation, open all packages and check contents of shipment. Please report any shortages directly to Vintage Air within 15 days. After 15 days, Vintage Air will not be responsible for missing or damaged items. Packing list located on last page of instructions.



www.vintageair.com

Important Notice—Please Read

For Maximum System Performance, Vintage Air Recommends the Following:

NOTE: Vintage Air systems are designed to operate with R134a refrigerant only. Use of any other refrigerant could damage your A/C system and/or vehicle, and possibly cause a fire, in addition to potentially voiding the warranties of the A/C system and its components.

Refrigerant Capacities:

Vintage Air System: 1.8 lbs. (28.8 oz.) or 816 grams of **R134a**, charged by weight with a quality charging station or scale. **NOTE: Use of the proper type and amount of refrigerant is critical to system operation and performance.**

Other Systems: Consult manufacturer's guidelines.

Lubricant Capacities:

New Vintage Air-Supplied Sanden Compressor: No additional oil needed (Compressor is shipped with proper oil charge).

All Other Compressors: Consult manufacturer (Some compressors are shipped dry and will need oil added).

Safety Switches

Your Vintage Air system is equipped with a binary pressure safety switch. A binary switch disengages the compressor clutch in cases of extreme low pressure conditions (refrigerant loss) or excessively high head pressure (406 PSI) to prevent compressor damage or hose rupture. A trinary switch combines Hi/Lo pressure protection with an electric fan operation signal at 254 PSI, and should be substituted for use with electric fans. Compressor safety switches are extremely important since an A/C system relies on refrigerant to circulate lubricant.

Service Info:

Protect Your Investment: Prior to assembly, it is critical that the compressor, evaporator, A/C hoses and fittings, hardlines, condenser and receiver/drier remain capped. Removing caps prior to assembly will allow moisture, insects and debris into the components, possibly leading to reduced performance and/or premature failure of your A/C system. This is especially important with the receiver/drier.

Additionally, when caps are removed for assembly, **BE CAREFUL!** Some components are shipped under pressure with dry nitrogen.

Evacuate the System for 35-45 Minutes: Ensure that system components (Drier, compressor, evaporator and condenser) are at a temperature of at least 85°F. On a cool day, the components can be heated with a heat gun *or* by running the engine with the heater on before evacuating. Leak check and charge to specifications.

Bolts Passing Through Cowl and/or Firewall:

To ensure a watertight seal between the passenger compartment and the vehicle exterior, for all bolts passing through the cowl and/or firewall, Vintage Air recommends coating the threads with silicone prior to installation.

Heater Hose (not included with this kit):

Heater hose may be purchased from Vintage Air (Part#31800-VUD) or your local parts retailer. Routing and required length will vary based on installer preference.



www.vintageair.com

Core Support Measurements

This kit was developed based on the measurements below, which were taken from a 1969 Dodge Charger core support.

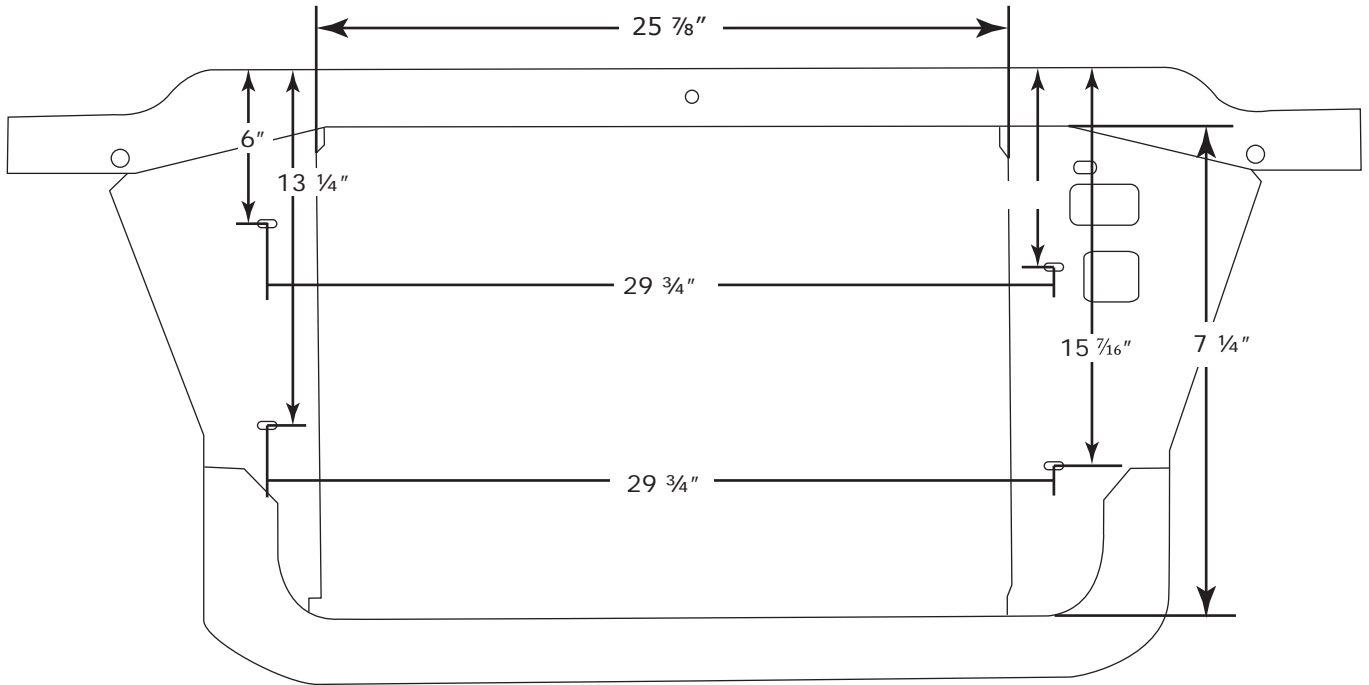

Front View

This modification was developed based on the measurements below, which were taken from a 1969 Dodge Coronet without factory air, with a 318 engine core support.

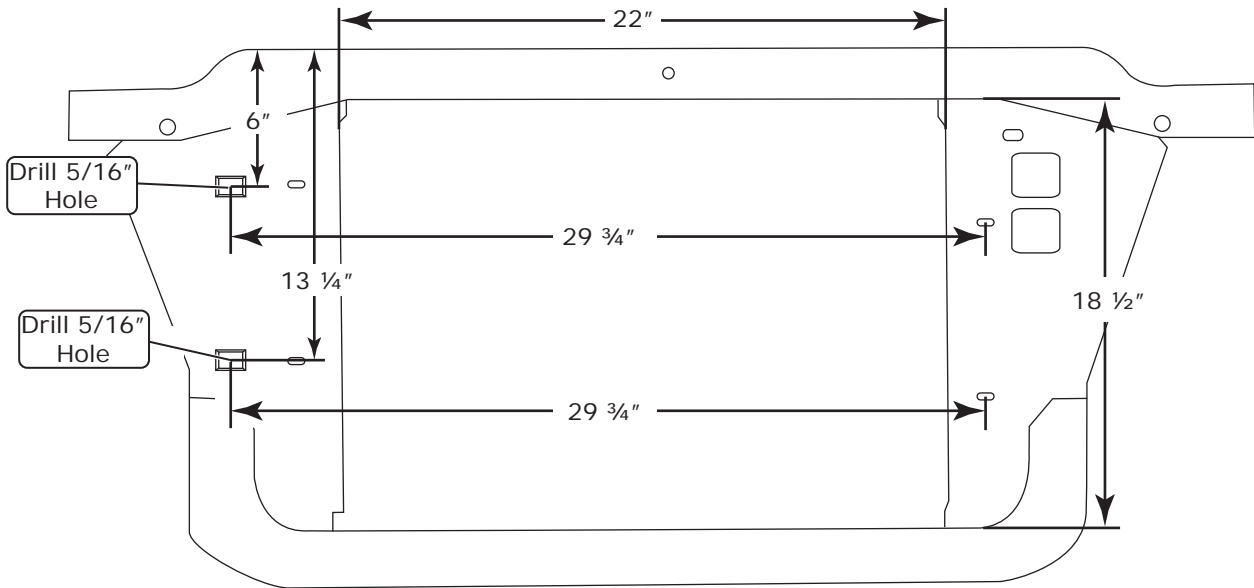

Front View



www.vintageair.com

Engine Compartment Disassembly

NOTE: Before starting the installation, check the function of the vehicle (horn, lights, etc.) for proper operation, and study the instructions, illustrations, photos & diagrams.

Perform the following:

1. Disconnect the battery.
2. Remove the battery (retain).
3. Drain the radiator.
4. Remove the radiator mounting bolts (discard), and replace them with 1/4-20 x 1/2" hex bolts and 1/4" flat washers.

Drier Installation

NOTE: Drier contains a desiccant that will quickly absorb moisture from the atmosphere and can lose effectiveness in less than 30 minutes. Remove caps and plugs only long enough to install safety switch and hardlines onto a sealed condenser assembly. Do not uncap again until ready to connect hoses and evacuate system before charging.

1. Insert the drier into the clamp on the passenger side condenser bracket assembly, and secure it with a 1/4" flat washer and a 1/4-20 nut with star washer (See Photos 1, 2 and 3, below). **NOTE: Do not fully tighten nut at this time. Refrigerant flow through drier is IN from condenser, OUT to evaporator.**

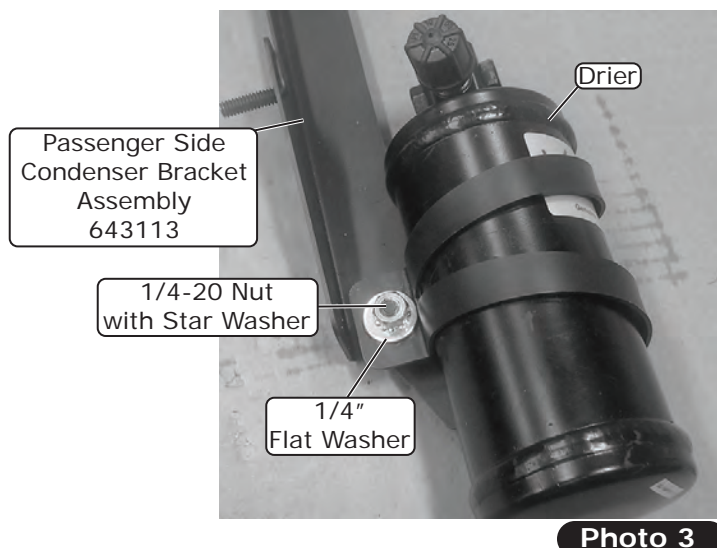
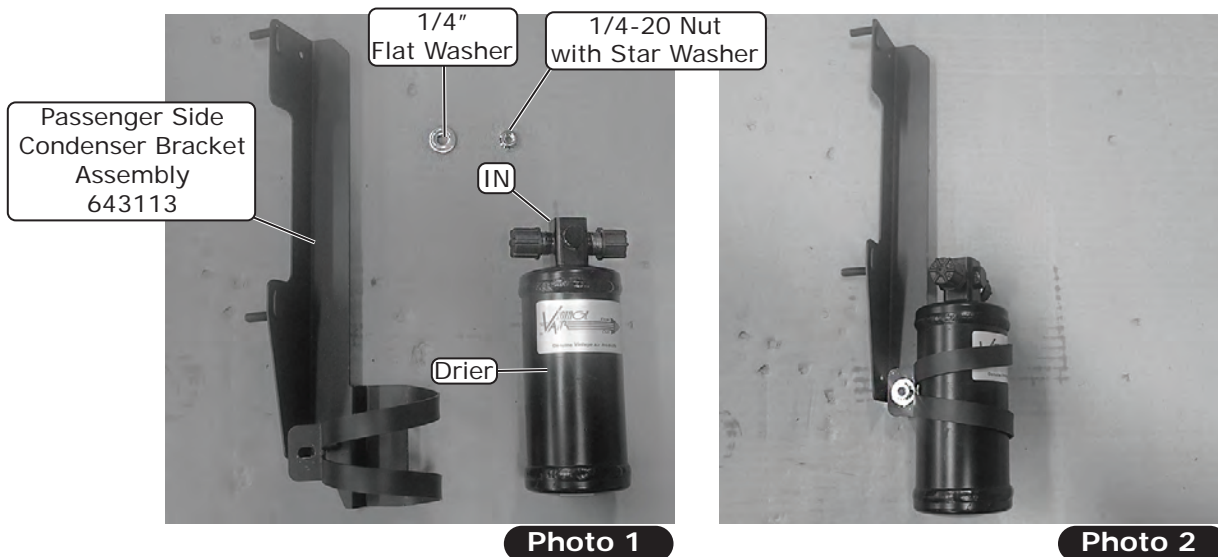



www.vintageair.com

Mounting Bracket Installation

1. Install the condenser mounting brackets onto the condenser using (4) 10-24 x 3/8" pan head screws and (4) 10-24 nuts with star washers as shown in Photos 1, 2, 3 and 4, below.

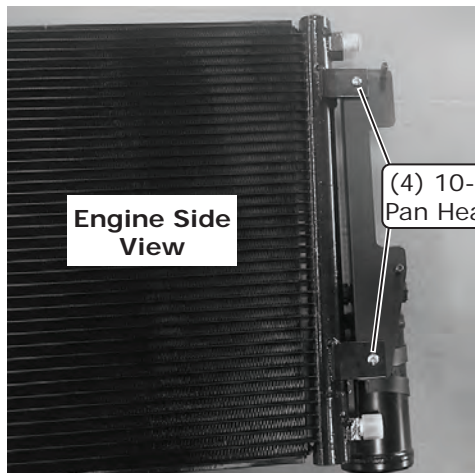

Photo 1

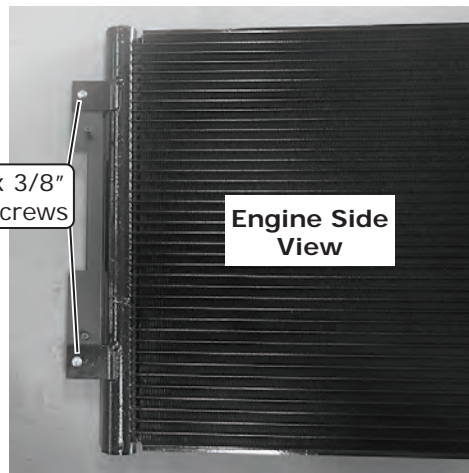

Photo 2

(4) 10-24 Nuts with Star Washers

Passenger Side Condenser Bracket Assembly 643113

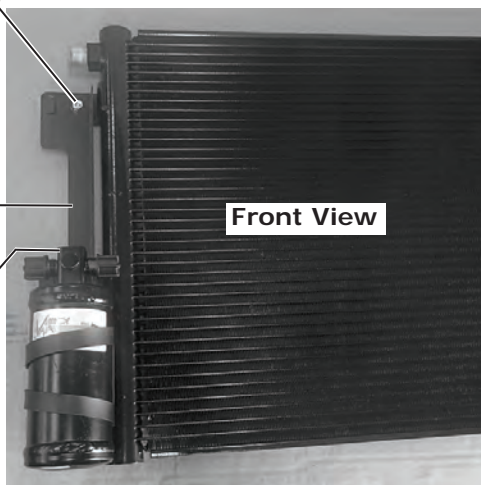

Photo 3

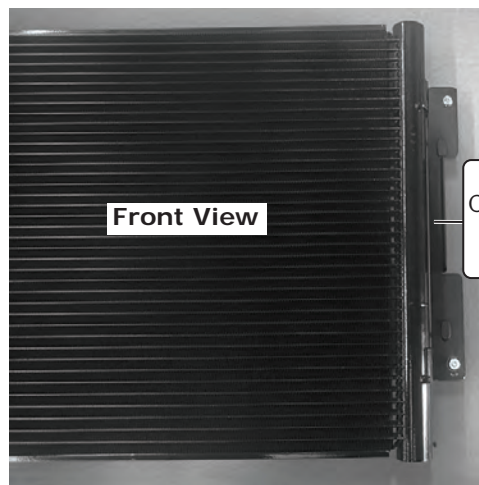
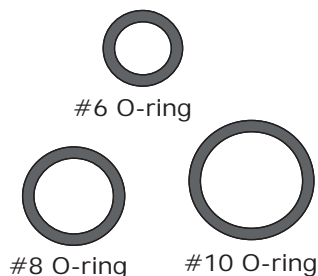

Photo 4

Driver Side Condenser Bracket Assembly 643111



Lubricating O-rings



NOTE: Standard torque specifications:
 #6: 11 to 13 ft-lb.
 #8: 15 to 20 ft-lb.
 #10: 21 to 27 ft-lb.

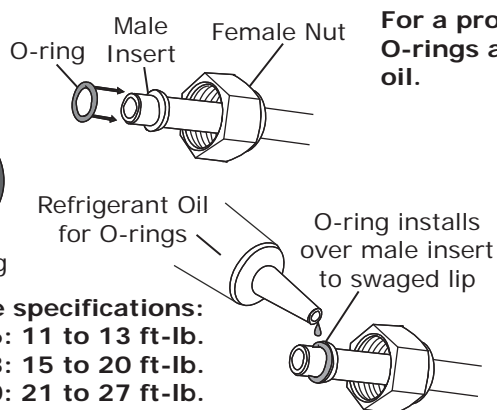

For a proper seal of fittings: Install supplied O-rings as shown and lubricate with refrigerant oil.

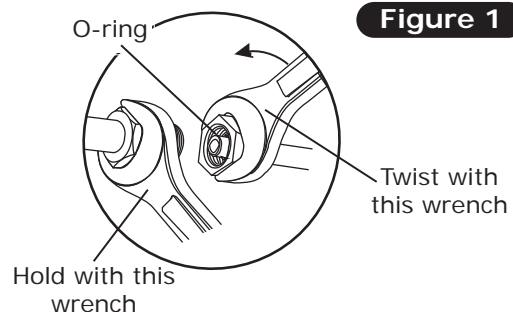

Figure 1



www.vintageair.com

#6 Drier/Condenser Hardline & Binary Switch Installation

1. Lubricate (2) #6 O-rings as shown in Figure 1, Page 6. Install the #6 drier/condenser hardline as shown in Photos 1 and 2, below. Tighten fittings as shown in Figure 1, Page 6. **NOTE: Orient the #6 drier/condenser hardline as shown in Photo 2, below. Reversing the hardline orientation will push the drier into the wrong position. Tighten the 1/4-20 nut with star washer securing the drier to the drier bracket at this time.**
2. Install binary switch onto the drier as shown in Photo 2, below. **NOTE: The binary switch and the drier each come with an O-ring. Only one of the (2) O-rings will be used.**

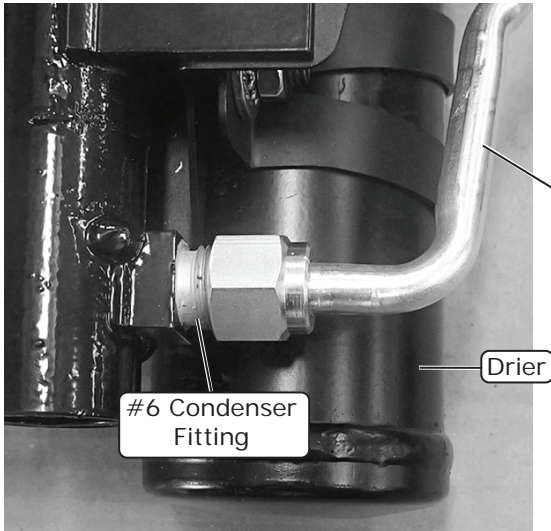

Photo 1

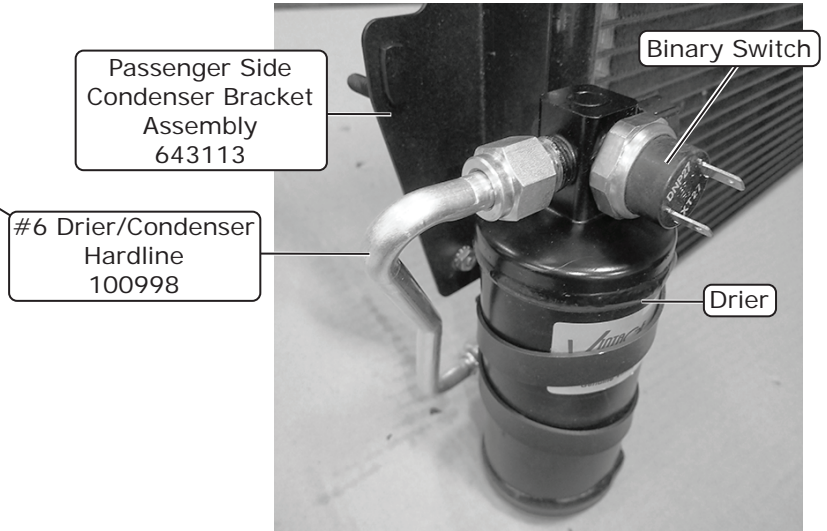

Photo 2

Nylon Spacer Installation

1. Install (4) 5/16" nylon spacers on the passenger and driver side condenser bracket weld studs as shown in Photos 1 and 2, below.

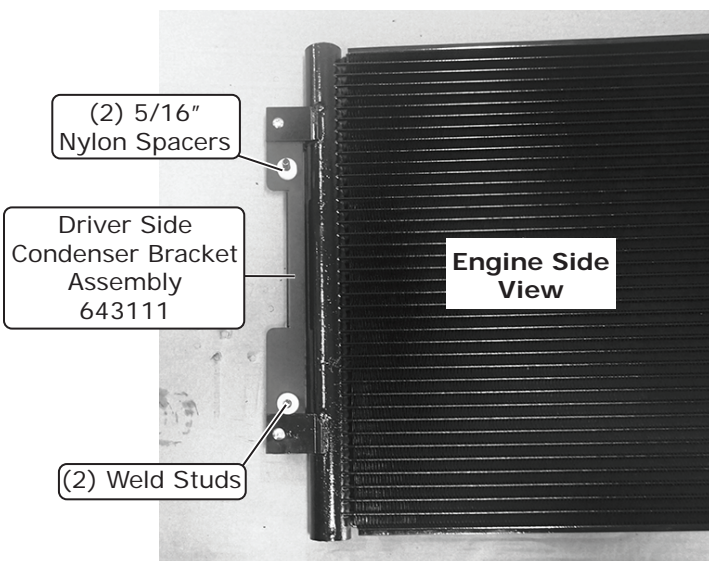

Photo 1

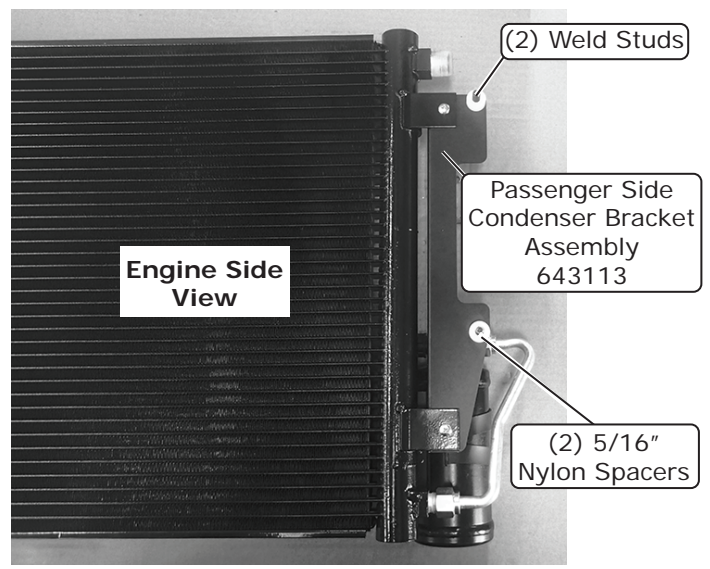

Photo 2



www.vintageair.com

Condenser Installation

1. Install the condenser assembly onto the front of the core support as shown in Figure 1, below.
2. Insert the (4) weld studs into the (4) OEM slots on the front of the core support, and secure the condenser using (4) 1/4-20 nuts with star washers and (4) 1/4" flat washers as shown in Figure 2, below.

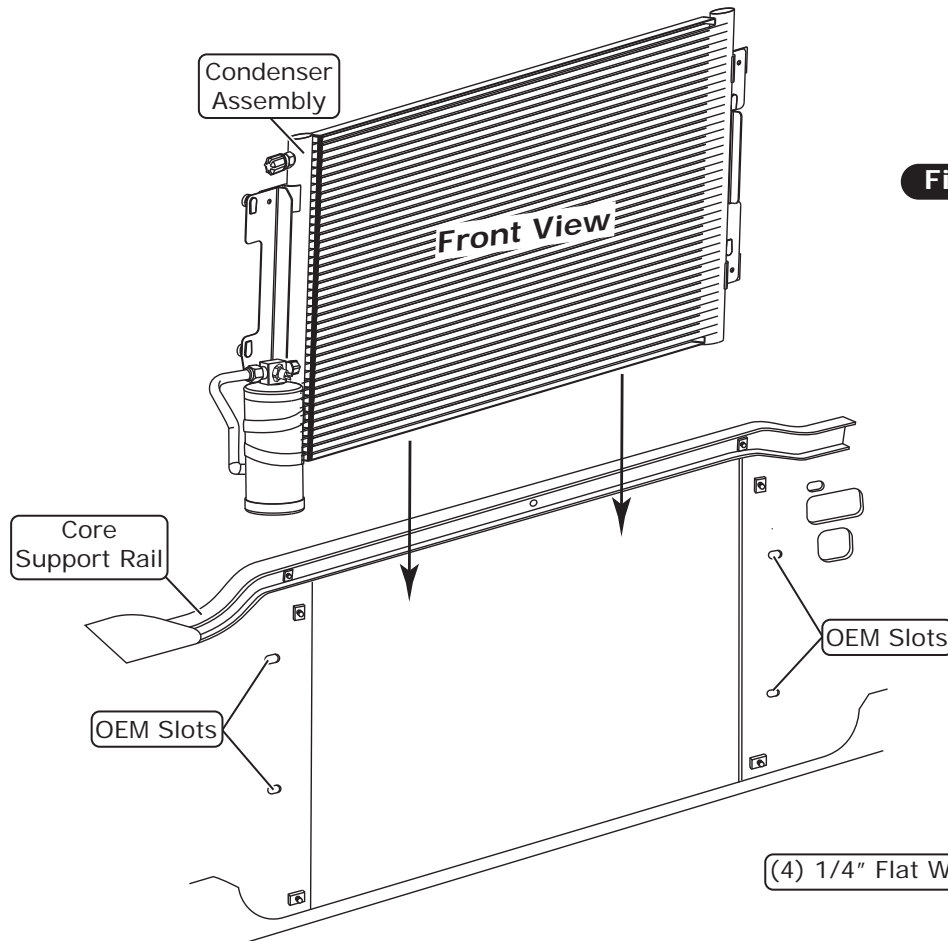

Figure 1

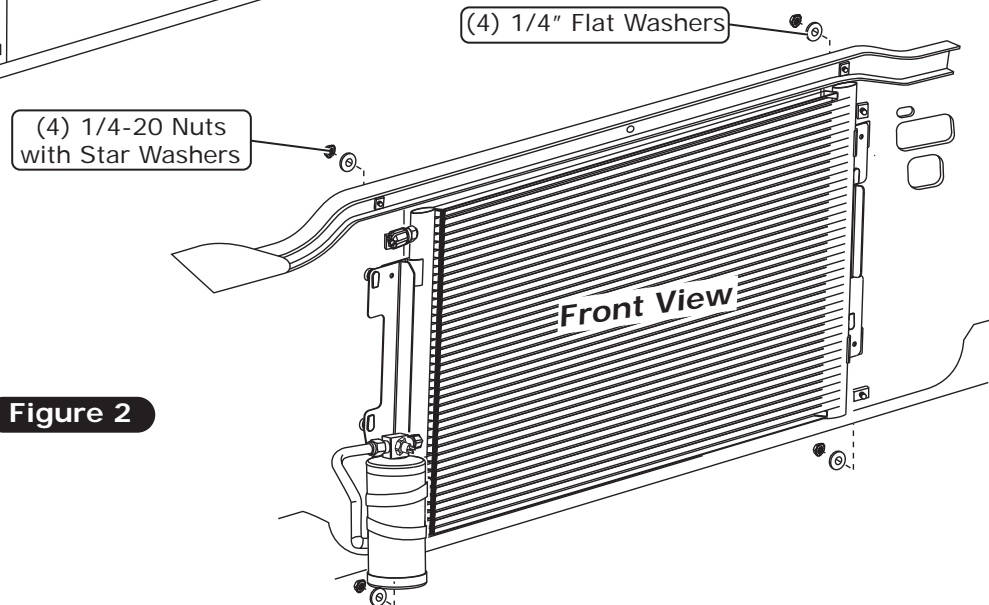

Figure 2



www.vintageair.com

#6 and #8 Hardline Installation

1. Lubricate a #6 O-ring as shown in Figure 1, Page 6. Install the #6 drier/core hardline onto the drier as shown in Photo 1, below. Tighten the fitting as shown in Figure 1, Page 6.
2. Lubricate a #8 O-ring as shown in Figure 1, Page 6. Install the #8 condenser hardline onto the #8 condenser fitting as shown in Photo 2, below. Tighten the fitting as shown in Figure 1, Page 6.

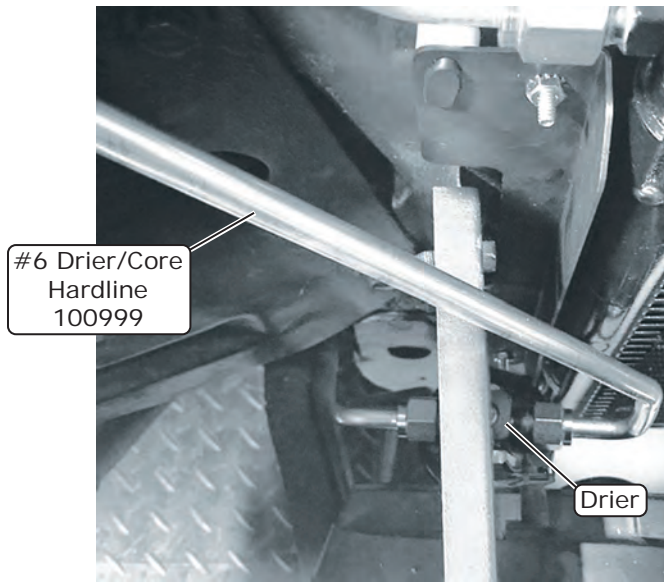

Photo 1

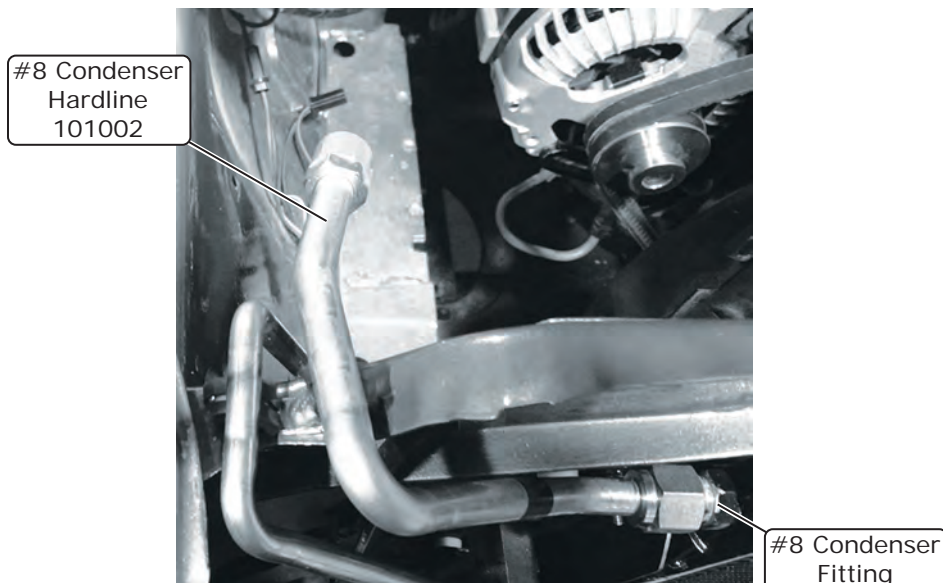

Photo 2



www.vintageair.com

Securing Hardlines

1. Install a 3/8" ID Adel clamp onto the #6 drier/core hardline, and a 1/2" ID Adel clamp onto the #8 condenser hardline. Using the OEM hole on the top of the core support, install a 10-32 x 3/4" pan head screw and a 10-32 nut with star washer to secure the hardline as shown in Photo 1, below. **NOTE: Some core supports may not have the OEM hole. In this case, measure 1" from the edge (See Photo 1, below), and drill a 3/16" hole through the top of the core support.**

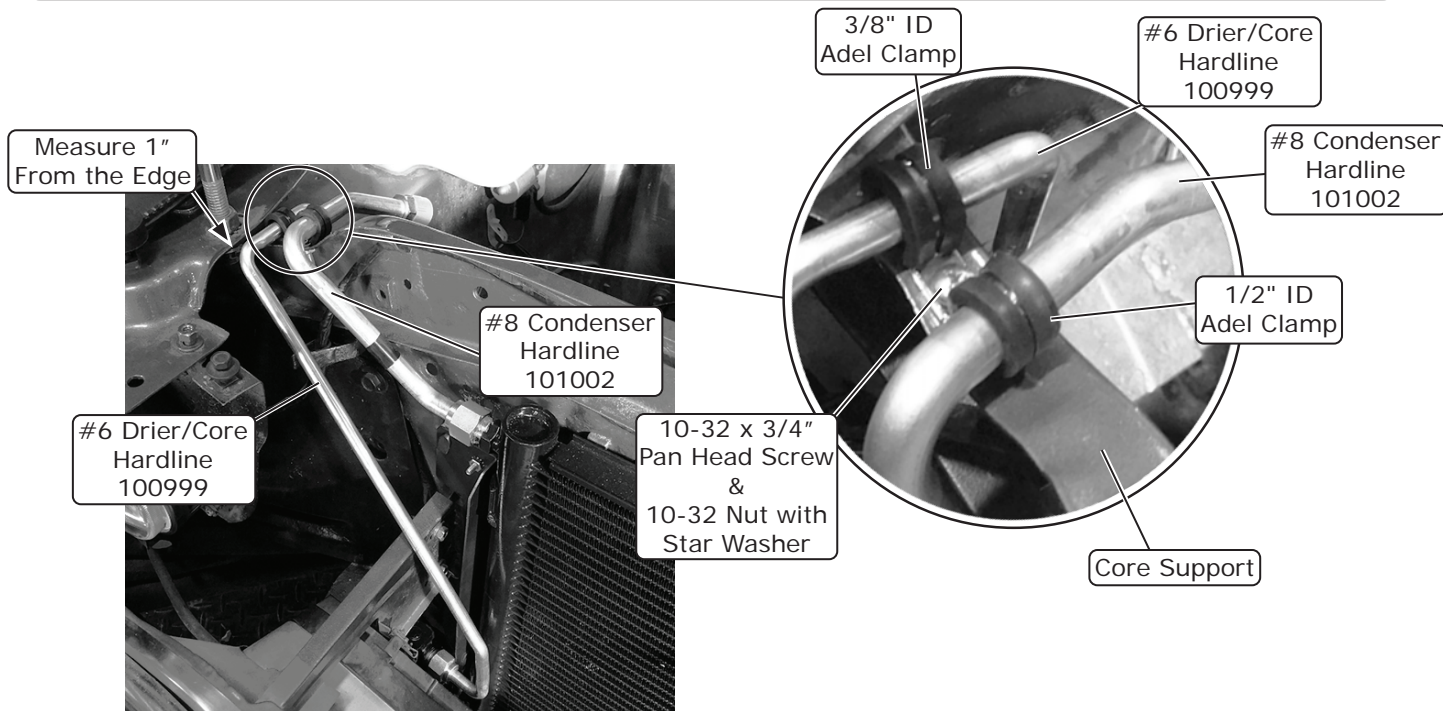

Photo 1

Final Steps

1. Reinstall and/or reconnect all remaining items removed or disconnected in the Engine Compartment Disassembly instructions on Page 5. This concludes the condenser kit portion of your installation.



www.vintageair.com

Packing List: Condenser Kit (051069)

O-rings/Refrigerant Oil

	Qty		Part No	Description
	1	<input type="checkbox"/>	11079-VUS	Binary Switch, Male
	4	<input type="checkbox"/>	180392	Spacer, .625" OD x .250" ID x .312" Length, Nylon
	5	<input type="checkbox"/>	18125-VUB	Washer, 1/4" USS, Flat
	5	<input type="checkbox"/>	18152-VUB	Nut with Star Washer, 1/4-20, Hex
	4	<input type="checkbox"/>	18249-VUB	Screw, 10-24 x 3/8", Pan Head
	1	<input type="checkbox"/>	18251-VUB	Nut with Star Washer, 10-32
	1	<input type="checkbox"/>	18258-VUB	Screw, 10-32 x 3/4"
	4	<input type="checkbox"/>	18260-VUB	Nut with Star Washer, 10-24
	4	<input type="checkbox"/>	18287-VUB	Bolt, 1/4-20 x 1/2", Hex
	1	<input type="checkbox"/>	23135-VUW	Compressor Lead
	1	<input type="checkbox"/>	31600-VUD	Adel Clamp, 3/8" I.D.
	1	<input type="checkbox"/>	31603-VUD	Adel Clamp, 1/2" I.D.

Packed By: _____

	Qty		Part No	Description
	4	<input type="checkbox"/>	33857-VUF	O-ring, #6
	3	<input type="checkbox"/>	33858-VUF	O-ring, #8
	1	<input type="checkbox"/>	41117-VUP	Refrigerant Oil

Packed By: _____

Brackets

	Qty		Part No	Description
	1	<input type="checkbox"/>	643111	Bracket, Condenser, Driver-Side
	1	<input type="checkbox"/>	643113	Bracket, Condenser, Passenger-Side

Packed By: _____

Hardlines/Hoses

	Qty		Part No	Description
	1	<input type="checkbox"/>	100998	Hardline, #6 Condenser/Drier
	1	<input type="checkbox"/>	100999	Hardline, #6 Drier/Core
	1	<input type="checkbox"/>	101002	Hardline, #8 Condenser

Packed By: _____

Condenser/Drier

	Qty		Part No	Description
	1	<input type="checkbox"/>	037030-OVR	Condenser, 16" x 28", Parallel Flow
	1	<input type="checkbox"/>	07321-VUC	Drier

Packed By: _____

Inspected By: _____

Date: _____

**NOTE: Images may not depict actual parts and quantities.
Refer to packing list for actual parts and quantities.**