



**SPAL Series Electric Fans**

SPAL is recognized worldwide as a leader in automotive engine cooling technologies. We offer the complete line of SPAL fans to our customers to assure optimum cooling system performance.

The illustrations are for typical reference only. Your dealer will be happy to supply you with specific CFM recommendations and mounting information.



**SPAL Series Electric Fans**

Part Number	Fan Diameter	Motor Thickness	Fan Thickness	CFM
<b>32141-SHF</b> .....	14" Puller .....	3.390 .....	1.100 .....	1720
<b>32140-SHF</b> .....	14" Pusher .....	3.390 .....	1.100 .....	1720
<b>32161-SHF</b> .....	16" Puller .....	3.390 .....	1.100 .....	2360
<b>32160-SHF</b> .....	16" Pusher .....	3.390 .....	1.100 .....	2360
<b>Extreme Duty 16"</b>				
<b>*287016-VUR</b> .....	16" Puller .....	3.640 .....	1.440 .....	3000
<b>*32111-SDF</b> .....	11" Dual Puller... (See below) (5 blade fan)	4.250 .....	2.600 .....	2780

\*These fans must use heavy duty wiring kit - see page 72  
Other smaller fan models available special order only. Allow 4-6 weeks delivery.

**NEW!**

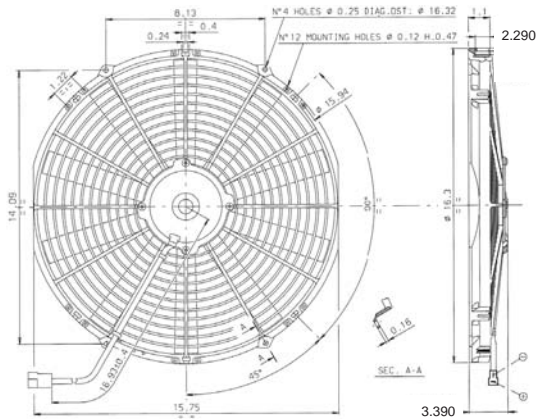

**40137-VUB**  
Mounting kit for all SPAL fans.

**SPAL Dual Fans**

Designed as a primary cooling fan packages. They can be mounted horizontally for use on 50's, 60's and 70's cars and trucks. Mounted vertically, they can be used on mid to late 30's street rods and trucks.

**32111-SDF** ..... 11" Dual Puller

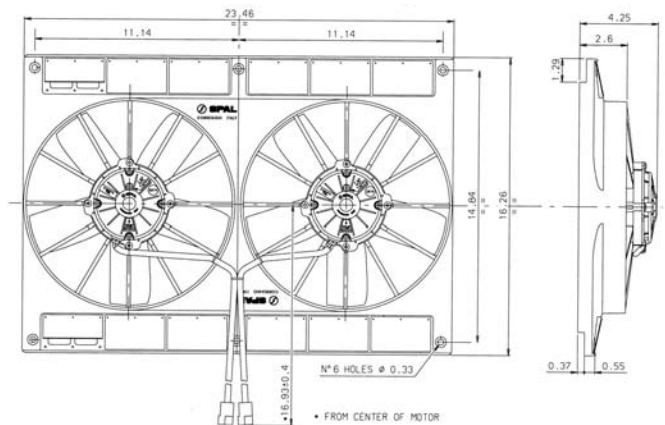

**TOTALLY COOLED GALLERY**

One of the earliest pro built street rods to feature Vintage Air was built for Jamie Mussleman of our home town, San Antonio. This unique and very rare Model B-400 was featured in several magazines of the time. The car was built by Hot Rods by Boyd and displayed all of the detail and finish quality Boyd is known for.